



GOVERNMENT OF TAMIL NADU

SYLLABUS

DIPLOMA IN AUTOMOBILE ENGINEERING (FULL TIME)

SECOND & THIRD YEAR

2011-2012

L - SCHEME



DIRECTORATE OF TECHNICAL EDUCATION
TAMIL NADU



SYLLABUS

DIPLOMA IN AUTOMOBILE ENGINEERING

Course Code: 1021

2011-2012

L - SCHEME



**DIRECTORATE OF TECHNICAL EDUCATION
GOVERNMENT OF TAMILNADU**

DIPLOMA COURSES IN ENGINEERING/TECHNOLOGY

(SEMESTER SYSTEM)

(Implemented from 2011- 2012)

L – SCHEME

REGULATIONS*

* *Applicable to the Diploma Courses other than Diploma in Hotel Management & Catering Technology and the Diploma Courses offered through MGR Film Institute, Chennai.*

1. Description of the Course:

a. Full Time (3 years)

The Course for the Full Time Diploma in Engineering shall extend over a period of three academic years, consisting of 6 semesters [❖] and the First Year is common to all Engineering Branches.

b. Sandwich (3½ years)

The Course for the Sandwich Diploma in Engineering shall extend over a period of three and half academic years, consisting of 7 semesters [❖] and the First Year is common to all Engineering Branches. The subjects of three years full time diploma course being regrouped for academic convenience.

During 4th and/or during 7th semester the students undergo industrial training for six months/ one year. Industrial training examination will be conducted after completion of every 6 months of industrial training

c. Part Time (4 years)

The course for the Part Time Diploma in Engineering shall extend over a period of 4 academic years containing of 8 semesters [❖], the subjects of 3 year full time diploma courses being regrouped for academic convenience.

[❖] Each Semester will have 16 weeks duration of study with 35 hrs. /Week for Regular Diploma Course and 18 hrs. / Week for Part-Time Diploma Course.

The Curriculum for all the 6 Semesters of Diploma courses (Engineering & Special Diploma Courses viz. Textile Technology, Leather Technology, Printing Technology, Chemical Technology etc.) have been revised and revised curriculum is applicable for the candidates admitted from 2011 – 2012 academic year onwards.

2. Condition for Admission:

Condition for admission to the Diploma courses shall be required to have passed in The S.S.L.C Examination of the Board of Secondary Education, Tamilnadu.

(Or)

The Anglo Indian High School Examination with eligibility for Higher Secondary Course in Tamilnadu

(Or)
The Matriculation Examination of Tamil Nadu.

(Or)
Any other Examinations recognized as equivalent to the above by the Board of Secondary Education, Tamilnadu.

Note: In addition, at the time of admission the candidate will have to satisfy certain minimum requirements, which may be prescribed from time to time.

3. Admission to Second year (Lateral Entry):

A pass in HSC (Academic)# or (Vocational) courses mentioned in the Higher Secondary Schools in Tamilnadu affiliated to the Tamilnadu Higher Secondary Board with eligibility for university Courses of study or equivalent examination, & Should have studied the following subjects

Sl. No	Courses	H.Sc Academic	H.Sc Vocational	
		Subjects Studied	Subjects Studied	
			Related subjects	Vocational subjects
1.	All the Regular and Sandwich Diploma Courses	Maths, Physics & Chemistry	Maths / Physics / Chemistry	Related Vocational Subjects Theory & Practical
2.	Diploma Course in Modern Office Practice	English & Accountancy English & Elements of Economics English & Elements of Commerce	English & Accountancy, English & Elements of Economics, English & Management Principles & Techniques, English & Typewriting	Accountancy & Auditing, Banking, Business Management, Co-operative Management, International Trade, Marketing & Salesmanship, Insurance & Material Management, Office Secretary ship.

Subject to the approval of the AICTE

- For the Diploma Courses related with Engineering/Technology, the related / equivalent subjects prescribed along with Practicals may also be taken for arriving the eligibility.
- Branch will be allotted according to merit through counseling by the respective Principal as per communal reservation.
- For admission to the Textile Technology, Leather Technology, Printing Technology, Chemical Technology and Modern Office Practice Diploma courses the candidates studied the related subjects will be given first preference.
- *Candidates who have studied Commerce Subjects are not eligible for Engineering Diploma Courses.*

4. Age Limit:No Age limit.

5. Eligibility for the Award of Diploma:

No candidate shall be eligible for the Diploma unless he/she has undergone the prescribed course of study for a period of not less than 3 academic years in any institution affiliated to the State Board of Technical Education and Training, Tamilnadu, when joined in First Year and two years if joined under Lateral Entry scheme in the second year and passed the prescribed examination.

The minimum and maximum period for completion of Diploma Courses are as given Below:

Diploma Course	Minimum Period	Maximum Period
Full Time	3 Years	6 Years
Full Time(Lateral Entry)	2 Years	5 Years
Sandwich	3½ Years	6½ Years
Part Time	4 Years	7 Years

6. Subjects of Study and Curriculum outline:

The subjects of study shall be in accordance with the syllabus prescribed from time to time, both in theory and practical subjects. The curriculum outline is given in Annexure - I

7. Examinations:

Board Examinations in all subjects of all the semesters under the scheme of examinations will be conducted at the end of each semester.

The internal assessment marks for all the subjects will be awarded on the basis of continuous internal assessment earned during the semester concerned. For each subject 25 marks are allotted for internal assessment and 75 marks are allotted for Board Examination.

8. Continuous Internal Assessment:

A. For Theory Subjects:

The Internal Assessment marks for a total of 25 marks, which are to be distributed as follows:

i) Subject Attendance

5 Marks

(Award of marks for subject attendance to each subject Theory/Practical will be as per the range given below)

80% - 83%	1 Mark
84% - 87%	2 Marks
88% - 91%	3 Marks
92% - 95%	4 Marks
96% - 100%	5 Marks

ii) Test #

10 Marks

2 Tests each of 2 hours duration for a total of 50 marks are to be conducted. Out of which the best one will be taken and the marks to be reduced to:

05 marks

The Test – III is to be the Model test covering all the five units and the marks so obtained will be reduced to :

05 marks

Total 10 marks

TEST	UNITS	WHEN TO CONDUCT	MARKS	DURATION
Test I	Unit – I & II	End of 6 th week	50	2 Hrs
Test II	Unit – III & IV	End of 12 th week	50	2 Hrs
Test III	Model Examination - Compulsory Covering all the 5 Units. (Board Examinations-question paper-pattern).	End of 16 th week	75	3 Hrs

- From the Academic year 2011-2012 onwards.

Question Paper Pattern for the Periodical Test :(Test - I & Test- II)

14 Questions X 1 mark	14 marks
6 Questions X 6 marks } (OR) 3 Questions X 12 marks }	36 marks
Total	-----	50 marks

iii) Assignment

10 Marks

For each subject Three Assignments are to be given each for 20 marks and the average marks scored should be reduced for 10 marks

All Test Papers and Assignment notebooks after getting the signature with date from the students must be kept in the safe custody in the Department for verification and audit. It should be preserved for 2 Semesters and produced to the flying squad and the inspection team at the time of inspection/verification.

B. For Practical Subjects:

The Internal Assessment mark for a total of 25 marks which are to be distributed as follows:-

a) Attendance	:	5 Marks	(Award of marks same as theory subjects)
b) Procedure/ observation and tabulation/ Other Practical related Work	:	10 Marks	
c) Record writing	:	10 Marks	

TOTAL	:	25 Marks	

- All the Experiments/Exercises indicated in the syllabus should be completed and the same to be given for final Board examinations.
- The Record for every completed exercise should be submitted in the subsequent Practical classes and marks should be awarded for 20 for each exercise as per the above allocation.
- At the end of the Semester, the average marks of all the exercises should be calculated for 20 marks and the marks awarded for attendance is to be added to arrive at the internal assessment mark for Practical. (20+5=25 marks)
- The students have to submit the duly signed bonafide record note book/file during the Practical Board Examinations.

- All the marks awarded for assignments, Tests and attendance should be entered in the Personal Log Book of the staff, who is handling the subject. This is applicable to both Theory and Practical subjects.

9. Communication and Life Skills Practical:

The Communication and Life Skills Practical with more emphasis is being introduced in IV Semester for Circuit Branches and in V Semester for other branches of Engineering.

Much Stress is given on:

- ❖ Monodic Communication
- ❖ Dyadic Communication
- ❖ Professional Communication
- ❖ Pronunciation
- ❖ Writing Resumes
- ❖ Interview Techniques

Internal Assessment Mark **25 Marks**

10. Project Work:

The students of all the Diploma Courses (**except Diploma in Modern Office Practice**) have to do a Project Work as part of the Curriculum and in partial fulfillment for the award of Diploma by the State Board of Technical Education and Training, Tamilnadu. In order to encourage students to do worthwhile and innovative projects, every year prizes are awarded for the best three projects i.e. institution wise, region wise and state wise. **The Project work must be reviewed twice in the same semester.**

a) Internal assessment mark for Project Work & Viva Voce:

Project Review I	...	10 marks
Project Review II	...	10 marks
Attendance	...	05 marks (Award of marks same as theory Subject pattern)

Total	...	25 marks

Proper record to be maintained for the two Project Reviews, and It should be preserved for 2 Semesters and produced to the flying squad and the inspection team at the time of inspection/verification.

b) Allocation of Marks for Project Work & Viva Voce in Board Examinations:

Viva Voce	...	25 marks
Demonstration/Presentation	...	20 marks

Total	...	45 marks

c) Written Test Mark (from 3 topics for 1 hour duration): \$

i) Entrepreneurship	5 questions X 2 marks	=	10 marks
ii) Environment Management	5 questions X 2 marks	=	10 marks
iii) Disaster Management	5 questions X 2 marks	=	10 marks

			30 marks

\$ - Selection of Questions should be from Question Bank, by the External Examiner.
No choice need be given to the candidates.

Project Work & Viva Voce in Board Examination	--	45 Marks
Written Test Mark (from 3 topics for 1 hour duration)	--	30 Marks
TOTAL	--	75 Marks

A neatly prepared PROJECT REPORT as per the format has to be submitted by individual student during the Project Work & Viva Voce Board examination.

11. Scheme of Examinations:

The Scheme of examinations for subjects is given in **Annexure - II**.

12. Criteria for Pass:

1. No candidate shall be eligible for the award of Diploma unless he/she has undergone the prescribed course of study successfully in an institution approved by AICTE and affiliated to the State Board of Technical Education & Training, Tamil Nadu and pass all the subjects prescribed in the curriculum.
2. A candidate shall be declared to have passed the examination in a subject if he/she secures not less than *40% in theory subjects* and *50% in practical subjects* out of the total prescribed maximum marks including both the Internal Assessment and the Board Examinations marks put together, subject to the condition that he/she secures at least a minimum of *30 marks out of 75 marks in the Board Theory Examinations and a minimum of 35 marks out of 75 marks in the Board Practical Examinations.*

13. Classification of successful candidates:

Classification of candidates who passed out the final examinations from April 2014 onwards (Joined in first year in 2011-2012) will be done as specified below.

First Class with Distinction:

A candidate will be declared to have passed in **First Class with Distinction** if he/she secures not less than 75% of the aggregate marks in all semesters put together except I and II semesters and passes all the above semesters in the first appearance itself and completes all subjects including that of I & II semesters within the stipulated period of study 3/ 3½/ 4 years (Full Time/Sandwich/Part Time) without any break in study.

First Class:

A candidate will be declared to have passed in **First Class** if he/she secures not less than 60% of the aggregate marks in all semesters put together except I & II semesters and completes all subjects including that of the I & II semesters within the stipulated period of study 3/ 3½ / 4 years (Full Time/Sandwich/Part Time) without any break in study.

Second Class:

All other successful candidates will be declared to have passed in **Second Class**.

The above mentioned classifications are also applicable for the Sandwich / Part-Time students who passed out Final Examination from October 2014 /April 2015 onwards (both joined in First Year in 2011-2012)

14. Duration of a period in the Class Time Table:

The duration of each period of instruction is 1 hour and the total period of instruction hours excluding interval and Lunch break in a day should be uniformly maintained as 7 hours corresponding to 7 periods of instruction (Theory & Practical).

-xx-

Chairperson

Thiru.Ramesh Chand Meena, I.A.S

Commissioner of Technical Education
Directorate of Technical Education
Chennai-600025

Co-ordinator

B.Nandagopal, Principal,
Murugappa Polytechnic College,
Avadi, Chennai – 62

Convener

R.Sornakumar, Principal
Govt. Polytechnic College,
Thiruvannamalai – 606 705

Members

- 1. Thiru D.S. Janardhanan** Vice President – Product Engg.
Rane TRW Steering Systems Ltd.,
- 2. Thiru C.Karuppanan**, Pricipal I/c
C I T Sandwich Polytechnic College, Coimbatore
- 3. Thiru E,Sundaramoorthy**, Principal
Swamy Abedhananda Polytechnic College, Thellar.
- 4. Thiru M.Sugumaran**, Workshop Supdt.,
Ramakrishna Mission Polytechnic College, Mylapore.
- 5. Thiru N.Thirunavukkarasu**, Lecturer
Central Polytechnic College, Tharamani, Chennai.

HIGHLIGHTS OF CURRICULUM AND SYLLABUS OF II & III YEAR

DIPLOMA IN AUTOMOBILE ENGINEERING – L SCHEME

SALIENT FEATURES OF CURRICULUM & SYLLABI

- Seven subjects per semester (3 Theory + 4 Practicals) / (4 Theory + 3 Practicals).
- Machine Drawing is introduced as two subjects namely:
 1. Machine Drawing (Manual Drafting)
 2. Computer Aided Machine Drawing Practical
- A new Practical Subject on “Mechanical Testing and Quality Control Practical” is introduced in III Semester.
- A new Theory and Practical Subject on “Industrial Automation” are introduced in IV Semester.
- A new Theory Subject as an “Elective – I” is introduced in V Semester.

Elective Subjects

In V semester the following electives Theory subjects are offered:

1. Alternate fuels and Energy systems.
2. Automobile Maintenance.
3. Industrial Robotics

In VI Semester the following elective theory and related practical subjects are offered

Elective Theory	Elective Practical
Two & Three wheelers Technology	Two & Three wheelers Technology Practical
Tractor and Farm Equipments	Tractor and Farm Equipments Practical
Aeronautics Engineering	Aeronautics Engineering Practical

CLASSIFICATION OF SUBJECTS AS PER AICTE NORMS

Sl.no.	Category of Subjects	Percentage of subjects as per AICTE norm(Range)	No. of Subject in L-Scheme	Percentage of Subjects in L-Scheme
1.	Basic Subjects	20-35%	11	32.35
2.	Core Subjects	15-25%	6	17.65
3.	Applied Engineering and Technology Subjects	40-55%	15	44.12
4.	Diversified subjects	5-10%	2	5.58

COMPARISON OF L - SCHEME SYLLABUS WITH K - SCHEME SYLLABUS

III Semester

Code No.	L SCHEME	Addition / Deletion in K Scheme
22031	Strength of Materials *	12131 Solid Mechanics and Fluid power Systems Common with Mechanical Engg. Since Hydraulic and Pneumatic systems are included in the new subject Industrial Automation.
22032	Automobile Engines	12133 Automotive engines & 12161 Automotive Maintenance and Pollution Control Both the subjects are combined. 1. To avoid repetition. 2. Maintenance of the components is included in the other subjects.
22133	Automobile Chassis and Transmission	12151 Automotive Chassis & Transmission Chassis and their types are included.
22034	Machine Drawing *	12034 Machine Drawing - CAD* Common with Mechanical Engg. Considering the requirement of Industries, the students must understand the creation and reading of the manual drawing this was included again.
22035	Mechanical Testing & Quality Control Practical *	12135 Solid Mechanics and Fluid power systems lab Fluid power systems are shifted to new practical Industrial automation. This new subject is included common with Mechanical Engg.
22136	Automobile Chassis and Transmission Practical.	12155 Automotive Chassis & Transmission Laboratory No major changes – study experiment are removed.
20001	Computer Application Practical	New Subject Common to all Branches

IV Semester

Col.No.	L SCHEME	Addition / Deletion in K Scheme
22041	Manufacturing Technology – I *	12032 Manufacturing Process* Common with Mechanical Engg.
22142	Heat Power Engineering	12041 Applied Thermodynamics* Based on the requirement for Placement examinations Steam and its applications, Refrigeration and Air conditioning are included. Air compressor and Steady flow energy equations are deleted. This is a common subject for all allied Mechanical Engg. courses.
22143	Industrial Automation	New Subject Based on the requirement of automation in the industries. Study of Hydraulic system, Pneumatic system and PLC are included.

22144	Computer Aided Machine Drawing Practical *	12034 Machine Drawing - CAD* Common with Mechanical Engg. Considering the latest trends in the Industry. The students are trained to create machine components drawing in 2D and 3D modelling in the Auto CAD Package.
22145	Manufacturing Technology – I Practical *	12036 Work shop – I (Smithy, Foundry & Welding)* Common with Mechanical Engg.
22146	Heat Power Engineering Practical	12144 Automotive engines Laboratory Dismantling and assembly parts are removed. Emission testing experiments are included.
22147	Industrial Automation Practical.	New Practical Based on the requirement of automation in the industry. Experiments in the Hydraulic system, Pneumatic system and PLC are included.

V Semester

Col.No.	L SCHEME	Addition / Deletion in K Scheme
22151	Industrial Management and Road Transport Organisation	12153 Industrial management and Road Transport Organization No major changes
22052	Manufacturing Technology – II *	12042 Machine shop Technology * Common with Mechanical Engg.
22153	Autotronics	12143 Automotive Electrical & Electronics Systems Latest Electronics devices and Computer applications in Automobiles are included.
	<u>Elective-I Theory</u>	New Subject
22171	1.Alternate fuels and Energy systems	Considering recent technological development this new subject is included as elective. Three subjects are included.
22172	2.Automobile Maintenance	
22173	3. Industrial Robotics	
22155	Autotronics Practical	12145 Autotronics Laboratory The experiments are rearranged to conduct experiment with kit.
22056	Manufacturing Technology – II Practical *	12046 Workshop II (Turning, Drilling and Shaping)* Common with Mechanical Engg.
20002	Communication & Life Skills Practical **	11011 English Communication Practical** Common with all branches.

VI Semester

Col.No.	L SCHEME	Addition / Deletion in K Scheme
22161	Body Building Engineering.	12152 Vehicle Body Engineering No major changes- Painting is included.
22062	Computer Integrated Manufacturing *	12062 Computer Aided Design and Manufacturing * Common with Mechanical Engg.
	<u>Elective-II Theory</u>	Elective Theory (VI Sem)

22181	1.Two and Three Wheeler Technology	1. Two & Three wheelers Technology No major changes – Detail contents are added.
22182	2.Tractor and Farm Equipments	2. Tractor and Farm Equipments No major changes.
22183	3.Aeronautics Engineering	One new elective is added. Considering the students to make eligible for Aeronautics engg. - for their higher studies.
22064	Computer Integrated Manufacturing Practical *	12064 Computer Aided design and Manufacturing Practical * Common with Mechanical Engg. CAD is removed only Simulation and CNC machine production are included. Based on the Industrial requirement.
22165	Automobile workshop Pratical	12156 Automobile Workshop Garage maintenance and repair of automobiles are included.
	<u>Elective-II Practical</u>	Elective Practical
22184	1.Two and Three Wheeler Technology Practical	1. Two & Three wheelers Technology Practical No major changes.
22185	2.Tractor and Farm Equipments Practical	2. Tractor and Farm Equipments Practical No major changes.
22186	3.Aeronautics Engineering Practical	One new elective practical is added. Considering the students to make eligible for Aeronautics engg. for their higher studies.
22167	Project Work, Entrepreneurship, Environmental and Disaster Management *	Project work, Entrepreneurship, Environment and Disaster Management Common with all branch of Engg.

** Common with all branches
*Common with Mechanical Engg.

Curriculum and Scheme of Examination
Diploma in Automobile Engineering (Full Time) (COURSE No: 1021)
L – Scheme (With effect from 2011-2012)

ALTERNATE SUBJECTS for K Scheme

III Semester

Subject Code	K SCHEME	Subject Code	L SCHEME
12131	Solid Mechanics and Fluid power Systems	22031	Strength of Materials *
12032	Manufacturing Process*	22041	Manufacturing Technology – I *
12133	Automotive engines	22132	Automobile Engines
12034	Machine Drawing - CAD*	22044	Computer Aided Machine Drawing Practical*
12135	Solid Mechanics and Fluid power systems lab.	22035	Mechanical Testing & Quality Control Practical *
12036	Work shop – I (Smithy, Foundry & Welding)*	22045	Manufacturing Technology – I Practical *

IV Semester

Subject Code	K SCHEME	Subject Code	L SCHEME
12041	Applied Thermodynamics*	22142	Heat Power Engineering.
12042	Machine shop Technology*	22052	Manufacturing Technology – II *
12143	Automotive Electrical & Electronics Systems	22153	Autotronics
12144	Automotive Engines laboratory	22146	Heat Power Engineering Practical
12145	Autotronics Laboratory	22155	Autotronics Practical
12046	Workshop II (Turning, Drilling and Shaping)*	22056	Manufacturing Technology – II Practical*

* Common to Diploma Mechanical Engineering

** Common to all Diploma Courses

V Semester

Subject Code	K SCHEME	Subject Code	L SCHEME
12151	Automotive Chassis & Transmission	22133	Automotive Chassis and Transmission
12152	Vehicle Body Engineering	22161	Body Building Engineering.
12153	Industrial management and Road Transport Organization	22151	Industrial Management and Road Transport Organisation
11011	English Communication Practical**	20002	Communication & Life Skills Practical **
12155	Automotive Chassis & Transmission Laboratory	22136	Automotive Chassis and Transmission Practical
12156	Automobile Workshop	22165	Automobile Workshop Practical

VI Semester

Subject Code	K SCHEME	Subject Code	L SCHEME
12161	Automotive Maintenance and Pollution Control	22132	Automobile Engines
12062	Computer Aided Design and Manufacturing *	22062	Computer Integrated Manufacturing *
12181 12182	Elective Theory 1. Two & Three wheelers Technology 2. Tractor and Farm Equipments	22181 22182	Elective-II Theory 1. Two and Three Wheeler Technology 2. Tractor and Farm Equipments
12064	Computer Aided design and Manufacturing Practical *	22064	Computer Integrated Manufacturing Practical *
12183 12184	Elective Practical 1. Two & Three wheelers Technology Practical 2. Tractor and Farm Equipments Practical	22184 22185	Elective-II Practical 1. Two and Three Wheeler Technology Practical 2. Tractor and Farm Equipments Practical
12166	Project work, Entrepreneurship, Environment and Disaster management	22167	Project Work**

* Common to Diploma Mechanical Engineering

** Common to all Diploma Courses

ANNEXURE-I

CURRICULUM OUTLINE DIPLOMA IN AUTOMOBILE ENGINEERING (FULL TIME)(1021)

THIRD SEMESTER

Subject Code	Subject	HOURS PER WEEK			
		Theory	Tutorial/ Drawing	Practical	Total
22031	Strength of Materials *	6	-	-	6
22132	Automobile Engines	6	-	-	6
22133	Automobile Chassis and Transmission	5	-	-	5
22034	Machine Drawing *	-	6	-	6
22035	Mechanical Testing & Quality Control Practical *	-	-	4	4
22136	Automobile Chassis and Transmission Practical	-	-	4	4
20001	Computer Application Practical **	-	-	4	4
TOTAL		17	6	12	35

* Common to Diploma Mechanical Engineering

** Common to all Diploma Courses

FOURTH SEMESTER

Subject Code	Subject	HOURS PER WEEK			
		Theory	Tutorial/ Drawing	Practical	Total
22041	Manufacturing Technology – I *	5	-	-	5
22142	Heat Power Engineering	6	-	-	6
22143	Industrial Automation	5	-	-	5
22044	Computer Aided Machine Drawing Practical*	-	-	5	5
22045	Manufacturing Technology – I Practical *	-	-	6	6
22146	Heat Power Engineering Practical	-	-	4	4
22147	Industrial Automation Practical	-	-	4	4
TOTAL		16	-	19	35

* Common to Diploma Mechanical Engineering

FIFTH SEMESTER

Subject Code	Subject	HOURS PER WEEK			
		Theory	Tutorial/ Drawing	Practical	Total
22151	Industrial Management and Road Transport Organisation	6	-	-	6
22052	Manufacturing Technology – II *	5	-	-	5
22153	Autotronics	5	-	-	5
22171	<u>Elective – I Theory</u> Alternate fuels and Energy systems	5	-	-	5
22172	Automobile Maintenance				
22173	Industrial Robotics				
22155	Autotronics Practical	-	-	4	4
22056	Manufacturing Technology–II Practical *	-	-	6	6
20002	Communication and Life Skills Practical **	-	-	4	4
TOTAL		21	-	14	35

* Common to Diploma Mechanical Engineering

** Common to all Diploma Courses

SIXTH SEMESTER

Subject Code	Subject	HOURS PER WEEK			
		Theory	Tutorial/ Drawing	Practical	Total
22161	Body Building Engineering.	5	-	-	5
22062	Computer Integrated Manufacturing *	5	-	-	5
22181	<u>Elective – II Theory</u> Two and Three Wheeler Technology	5	-	-	5
22182	Tractor and Farm Equipments				
22183	Aeronautics Engineering				
22064	Computer Integrated Manufacturing Practical *	-	-	6	6
22165	Automobile Workshop Practical	-	-	4	4
22184	<u>Elective - II Practical</u> Two and Three Wheeler Technology Practical			4	4
22185	Tractor and Farm Equipments Practical	-	-		
22186	Aeronautics Engineering Practical				
22167	Project Work *	-	-	6	6
TOTAL		15	-	20	35

* Common to Diploma Mechanical Engineering

ANNEXURE – II
SCHEME OF EXAMINATION
DIPLOMA IN AUTOMOBILE ENGINEERING (FULL TIME)
L-Scheme (With effect from 2011-2012)

THIRD SEMESTER

Subject Code	SUBJECT	Marks			Minimum for pass	Duration of Exam Hours
		Internal Assessment	Board Exam.	Total		
22031	Strength of Materials *	25	75	100	40	3
22132	Automobile Engines	25	75	100	40	3
22133	Automobile Chassis and Transmission	25	75	100	40	3
22034	Machine Drawing *	25	75	100	40	3
22035	Mechanical Testing & Quality Control Practical *	25	75	100	50	3
22136	Automobile Chassis and Transmission Practical	25	75	100	50	3
20001	Computer Application Practical **	25	75	100	50	3

* Common with Mechanical Engg.

** Common with all branches

FOURTH SEMESTER

Subject Code	SUBJECT	Marks			Minimum for pass	Duration of Exam Hours
		Internal Assessment	Board Exam.	Total		
22041	Manufacturing Technology – I *	25	75	100	40	3
22142	Heat Power Engineering	25	75	100	40	3
22143	Industrial Automation	25	75	100	40	3
22044	Computer Aided Machine Drawing *	25	75	100	50	3
22045	Manufacturing Technology – I Practical *	25	75	100	50	3
22146	Heat Power Engineering Practical	25	75	100	50	3
22147	Industrial Automation Practical	25	75	100	50	3

* Common with Mechanical Engg.

FIFTH SEMESTER

Subject Code	SUBJECT	Marks			Minimum for pass	Duration of Exam Hours
		Internal Assessment	Board Exam.	Total		
22151	Industrial Management and Road Transport Organisation	25	75	100	40	3
22052	Manufacturing Technology – II *	25	75	100	40	3
22153	Autotronics	25	75	100	40	3
22171 22172 22173	<u>Elective – I Theory</u> Alternate fuels and Energy systems Automobile Maintenance Industrial Robotics	25	75	100	40	3
22155	Autotronics Practical	25	75	100	50	3
22056	Manufacturing Technology–II Practical *	25	75	100	50	3
20002	Communication & Life Skills Practical **	25	75	100	50	3

* Common with Mechanical Engg.

** Common with all branches

SIXTH SEMESTER

Subject Code	SUBJECT	Marks			Minimum for pass	Duration of Exam Hours
		Internal Assessment	Board Exam.	Total		
22161	Body Building Engineering.	25	75	100	40	3
22062	Computer Integrated Manufacturing *	25	75	100	40	3
22181 22182 22183	<u>Elective – II Theory</u> Two and Three Wheeler Technology Tractor and Farm Equipments Aeronautics Engineering	25	75	100	40	3
22064	Computer Integrated Manufacturing Practical *	25	75	100	40	3
22165	Automobile Workshop Practical	25	75	100	50	3
22184 22185 22186	<u>Elective - II Practical</u> Two and Three Wheeler Technology Practical Tractor and Farm Equipments Practical Aeronautics Engineering Practical	25	75	100	50	3
22167	Project Work	25	75	100	50	3

* Common with Mechanical Engg.

III SEMESTER



DIPLOMA IN AUTOMOBILE ENGINEERING

L-SCHEME

2011-2012

22031 - STRENGTH OF MATERIALS

DIRECTORATE OF TECHNICAL EDUCATION

GOVERNMENT OF TAMILNADU

L-SCHEME
(Implements from the Academic year 2011-2012 onwards)

Course Name : DIPLOMA IN AUTOMOBILE ENGINEERING
Course Code : 1021
Subject Code : 22031
Semester : III
Subject Title : **STRENGTH OF MATERIALS**

TEACHING AND SCHEME OF EXAMINATIONS:

No. of Weeks per Semester : 16 Weeks

Subject	Instructions		Examination			Duration
	Hours/Week	Hours/Semester	Marks			
Strength of Materials	6	96	Internal Assessment	Board Examination	Total	3 Hrs
			25	75	100	

Topics and Allocation of Hours:

Unit No	Topics	Hours
I	DEFORMATION OF METALS	18
II	GEOMETRICAL PROPERTIES OF SECTIONS AND THIN SHELLS	18
III	LATERAL DEFORMATION (SF AND BM DIAGRAMS, DEFLECTION OF BEAMS)	18
IV	THEORY OF SIMPLE BENDING AND FRICTION	18
V	TORSION AND SPRINGS	18
	REVISION AND TEST	6
	Total	96

RATIONALE:

Day by day, engineering and technology experience tremendous growth. Design plays a major role in developing engineering and technology. Strength of material is backbone for design. The strength of material deals generally with the behaviour of objects, when they are subject to actions of forces. Evaluations derived from these basic fields provide the tools for investigation of mechanical structure.

OBJECTIVES:

- Define various mechanical properties of materials.
- Calculate the deformation of materials, which are subjected to axial load and shear.
- Determine the moment of Inertia of various sections used in industries.
- Estimate the stresses induced in thin shells.
- Draw the Graphical representation of shear force and bending moment of the beam subjected to different loads.
- Construct SFD and BMD.
- Calculate the power transmitted by the solid & hollow shafts.
- Distinguish different types of spring and their applications.

STRENGTH OF MATERIALS

DETAILED SYLLABUS

Contents: Theory

Unit	Name of the Topic	Hours
I	<p>DEFORMATION OF METALS</p> <p>Mechanical properties of materials: Engineering materials – Ferrous and non ferrous materials -Definition of mechanical properties such as strength – elasticity, plasticity, ductility, malleability, stiffness, toughness, brittleness, hardness, wear resistance, machinability, castability and weldability--Alloying elements-effect of alloying element - Fatigue, fatigue strength, creep – temperature creep – cyclic loading and repeated loading – endurance limit.</p> <p>Simple stresses and strains: Definition – Load, stress and strain – Classification of force systems – tensile, compressive and shear force systems – Behaviour of mild steel in tension up to rupture – Stress – Strain diagram – limit of proportionality – elastic limit – yield stress – breaking stress – Ultimate stress – percentage of elongation and percentage reduction in area – Hooke’s law – Definition – Young’s modulus - working stress, factor of safety, load factor, shear stress and shear strain - modulus of rigidity. Linear strain – Deformation due to tension and compressive force – Simple problems in tension, compression and shear force.</p> <p>Definition – Lateral strain – Poisson’s ratio – volumetric strain – bulk modulus – volumetric strain of rectangular and circular bars – problems connecting linear, lateral and volumetric deformation – Elastic constants and their relationship - Problems on elastic constants - Definition – Composite bar – Problem in composite bars subjected to tension and compression – Temperature stresses and strains – Simple problems – Definition – strain energy – proof resilience – modulus of resilience – The expression for strain energy stored in a bar due to Axial load – Instantaneous stresses due to gradual, sudden, impact and shock loads – Problems computing instantaneous stress and deformation in gradual, sudden, impact and shock loadings.</p>	18 Hrs
II	<p>GEOMETRICAL PROPERTIES OF SECTIONS AND THIN SHELLS</p> <p>Properties of sections: Definition – center of gravity and centroid - position of centroids of plane geometrical figures such as rectangle, triangle, circle and trapezium-problems to determine the centroid of angle, channel, T and I sections only - Definition-centroidal axis-Axis of symmetry. Moment of Inertia – Statement of parallel axis theorem and perpendicular axis theorem. Moment of Inertia of lamina of rectangle, circle, triangle, I and channel sections-Definition-Polar moment of Inertia-radius of gyration – Problems computing moment of inertia and radius of gyration for angle, T, Channel and I sections.</p> <p>Thin Shells: Definition – Thin and thick cylindrical shell – Failure of thin cylindrical shell subjected to internal pressure – Derivation of Hoop and longitudinal stress causes in a thin cylindrical shell subjected to internal pressure – simple problems – change in dimensions of a thin cylindrical shell subjected to internal pressure – problems – Derivation of tensile stress induced in a thin spherical shell subjected to internal pressure – simple problems – change in diameter and volume of a thin spherical shell due to internal pressure – problems.</p>	18 Hrs
III	<p>LATERAL DEFORMATION (SF AND BM DIAGRAMS, DEFLECTION OF BEAMS)</p> <p>Classification of beams – Definition – shear force and Bending moment – sign conventions for shear force and bending moment – types of loadings – Relationship between load, force and bending moment at a section – shear force diagram and bending moment diagram of cantilever and simply supported beam subjected to point load and uniformly distributed load (udl) – Determination of Maximum bending moment in cantilever beam and simply supported beam when</p>	18 Hrs

	they are subjected to point load and uniformly distributed load. Definition – slope, deflection, stiffness and flexural rigidity – Derivations of relationship between slope, Deflection and Radius of curvature – Derivation of slope and deflections of cantilever and simply supported beam by area moment method under point load and udl load– simple problems.	
IV	THEORY OF SIMPLE BENDING AND FRICTION Theory of simple bending – Assumptions – Neutral axis – bending stress distribution – moment of resistance – bending equation – $M/I=f/y=E/R$ – Definition – section modulus - rectangular and circular sections – strength of beam – simple problems involving flexural formula for cantilever and simple supported beam. Definition – force of friction – limiting friction- static – dynamic friction – angle of friction – co-efficient of friction – cone of friction – laws of static and dynamic friction – ladder problems	18 Hrs
V	TORSION AND SPRINGS $\frac{T}{J} = \frac{f_s}{R} = \frac{C\theta}{l}$ Theory of torsion – Assumptions – torsion equation – strength of solid and hollow shafts – power transmitted – Definition – Polar modulus – Torsional rigidity – strength and stiffness of shafts – comparison of hollow and solid shafts in weight and strength considerations – Advantages of hollow shafts over solid shafts – Problems. Types of springs – Laminated and coiled springs and applications – Types of coiled springs – Difference between open and closely coiled helical springs – closely coiled helical spring subjected to an axial load – problems to determine shear stress, deflection, stiffness and resilience of closed coiled helical springs.	18 Hrs

Text Books:

- 1) Strength of Materials ,R. S. Khurmi, , S.Chand & Co., Ram Nagar, New Delhi – 2002
- 2) Strength of Materials, S. Ramamrutham, 15th Edn 2004, Dhanpat Rai Pub. Co., New Delhi.

Reference Books:

- 1) Strength of Materials ,R.K. Bansal,, Laxmi Publications Pvt. Ltd., New Delhi, 3rd Edition, 2010.
- 2) Strength of materials, S.S.Rattan, Tata Mcgraw hill, New Delhi,2008, ISBN 9780070668959,
- 3) Strength of Materials, B K Sarkar, I Edition, 2003 Tata Mcgraw hill, New Delhi.
- 4) Engineering mechanics, R.K. Bansal, Laxmi Publications Pvt. Ltd., New Delhi, 2nd Edition, 2007

22031 STRENGTH OF MATERIALS

MODEL QUESTION PAPER – I

Time: 3 Hrs

Max Marks : 75

PART – A

Marks 15 x 1 = 15

Answer any 15 Questions – All Questions Carry Equal Marks

1. Define Ductility
2. State the relationship between E and K
3. State Hooke's law
4. What is lateral strain
5. State the parallel axis theorem
6. Define Hoop Stress
7. Define Thin cylindrical shell
8. Define Moment of inertia
9. What is radius of curvature
10. Define Slope
11. Define Bending moment
12. State the relationship between BM and SF
13. What is neutral axis
14. Write a formula for bending equation
15. Define section modulus
16. Define centre of curvature
17. What is twisting moment
18. State the application of laminated spring
19. List out the types of springs
20. What is polar moment of inertia.

PART – B
Marks 5 x 12=60

Answer all the Questions

- 21 a. i) A steel bar 2m long 20mm wide and 10mm thick is subjected to an axial pull of 20KN in the direction of its length. Determine the changes in length and volume. Take $E = 2 \times 10^5 \text{ N/mm}^2$ and $1/m = 0.3$ (4)
- ii) A brass tube of 50mm outside diameter, 45mm inside diameter and 300mm long is compressed between end washers with load of 24.5KN. Reduction in length is 0.0015mm. Determine the stress, strain and Young's modulus. (8)
- (or)
- b. A weight of 9.8KN is dropped on to a collar at the lower end of a vertical bar 3m long and 32mm diameter. Calculate the height of drop, if the maximum instantaneous stress is not to exceed 240 N/mm^2 . What is the corresponding instantaneous elongation? Assume $E = 2 \times 10^5 \text{ N/mm}^2$. (12)
22. a.i) Find the centroid of a channel section 100 x 50 x 15 mm (4)
- ii) Determine the change in diameter, change in volume of the spherical shell 2m in diameter and 12mm thick subjected to an internal pressure of 2 N/mm^2 . $E = 2 \times 10^5 \text{ N/mm}^2$ and $1/m = 0.25$ (4)
- (or)
- b. A thin cylindrical shell of 1m internal diameter 5mm thick and 2.5m long is filled with a fluid under pressure until its volume increases by $40 \times 10^6 \text{ mm}^3$. Determine the pressure exerted by the fluid on the shell. Take $E = 2 \times 10^5 \text{ N/mm}^2$ and $1/m = 0.25$ (12)
- 23 a. A beam is freely supported over a span of 8m. It carries a point load of 3KN at 2m from left hand support and an udl of 2KN/m from the centre upto the right hand support. Draw the SFD and BMD. (12)
- (or)
- b. A cantilever 2m long carries a point load of 20KN at 0.8m from the fixed end and another point load of 5KN at the free end. In addition, a udl of 15KN/m is spread over the entire length of the cantilever. Draw SFD and BMD (12)
- 24 a.i) State the assumptions made in the theory of Simple bending. (4)
- ii) A wooden beam of rectangular section 100 x 200 mm is simply supported over a span of 6m. Determine the udl it may carry, if the bending stress is not to exceed 7.5 N/mm^2 . Estimate the concentrated load it may carry at the centre of the beam with the same permissible stress. (8)
- (or)
- b.i) A beam of T-section flange 150mm x 50mm web thickness 50mm, overall depth 200mm and 10m long is simply supported a central point load of 10KN. Determine the maximum fibre stresses in the beam. (6)
- ii) Derive the flexural formula $\frac{M}{I} = \frac{f_b}{y} = \frac{E}{R}$ (6)

25. a) A truck weighing 30KN and moving at 5 Km/hr has to be brought to rest by buffer. Find how many springs, each of 18 coils will be required to the energy of motion during a compression of 200mm. The spring is made out of 25mm diameter steel rod coiled to a mean diameter of 240mm. Take $N = 0.84 \times 10^5 \text{ N/mm}^2$. (12)
- (or)
- b)i) A solid shaft 20mm diameter transmits 10KW at 1200rpm. Calculate the maximum intensity of shear stress induced and angle of twist in degrees in a length of 1m, if modulus of rigidity for the shaft material is $8 \times 10^4 \text{ N/mm}^2$. (6)
- ii) A closed coiled spring made of steel wire 100mm diameter has 10 coils of 120mm mean diameter. Calculate the deflection under an axial load of 100N and stiffness of the spring. Take $C = 1.2\text{mPa}$. (6)

22031 STRENGTH OF MATERIALS

MODEL QUESTION PAPER – II

Time: 3 Hrs

Max Marks : 75

PART – A

Marks 15 x 1 = 15

Answer any 15 Questions – All Questions Carry Equal Marks

1. Define toughness.
2. Define poisson's Ratio.
3. Define proof resilience.
4. Write any two elastic constant.
5. Define centroid.
6. Write down the unit of moment of Inertia.
7. Define thin cuclinder.
8. Define Moment of inertia
9. List out the types of beams.
10. Define sheer force.
11. Define the term deflection.
12. Define radius of curvature.
13. Define the term bending stress.
14. Define Neutral axis.
15. What is limiting friction?
16. Define Static friction.
17. Define pure torsion.
18. Write any two advantages of hollow shafts over solid shafts.
19. Give the applications of tension springs.
20. Define stiffness of spring.

PART – B
Marks 5 x 12=60

Answer all the Questions

- 21 a. i) Determine the value of Poisson's Ratio and Young's modulus of Rigidity of the material is $0.5 \times 10^5 \text{ N/mm}^2$ and bulk modulus $0.8 \times 10^5 \text{ N/mm}^2$ (6)
- ii) Draw stress – strain for a mild steel specimen loaded upto failure and explain the salient features. (6)
- (or)
- b.i) A copper rod 30mm is surrounded tightly by a cast iron tube of 60mm outside diameter the ends being firmly fastened together. When put to a compressive load of 12kN. What load will be shared by each? Also estimate the amount by which the compound bar shortens in a length of 10mm. Assume $E_C = 1.2 \times 10^5 \text{ N/mm}^2$ and $E_c = 1 \times 10^5 \text{ N/mm}^2$ (8)
- ii) Calculate the Strain Energy that can be stored in a steel bar 40mm in diameter and 3m long subjected to a pull of 100KN. Given $E=200\text{KN/mm}^2$ (4)
22. a.i) State Parallel axis theorem. (4)
- ii) An I-Section has the top Flange 120mm x 120mm thick, web 180mm x 20mm thick and the bottom flange 200mm x 40mm thick. Calculate the I_{xx} , I_{yy} , K_{xx} and K_{yy} of the section. (8)
- (or)
- b.i) What working pressure may be allowed in a boiler shell 1.8m diameters with plates 15mm thick, if the permissible tensile stress in the solid plate is not to exceed 70 N/mm^2 (3)
- ii) A Cylindrical Shell 24 m long, 600mm in diameter is made up of 15mm thick plates. Find the change in length, diameter and volume of the cylinder when the shell is subjected to an internal pressure of 2 N/mm^2 . $E=2 \times 10^5 \text{ N/mm}^2$ $1/m=0.3$ (9)
- 23 a. i) A cantilever of span 5m is loaded with three point load of 2KN at 2, 4, 5m from the fixed end in addition to a UDL of 1KN/m to a length of 4m from the fixed end. Draw SF and BM diagram. (6)
- ii) A simply supported beam of 5m span carries a UDL of 2 KN/m over the entire span. In addition the beam carries a point load of 4KN at a distance of 2m from the left support. Draw SFD and BMD. (6)
- (or)
- b.i) A Cantilever 2m long, 100mm wide and 200mm deep carries a concentrated load of 5KN at the free end. Find the max slope and deflection. $E= 2 \times 10^5 \text{ N/mm}^2$ (4)
- ii) A cantilever beam 6m long is subjected to a UDL of W KN/m over the entire span. Assuming Rectangular section with depth equal to twice the width determine the size of the beam so that the max deflection does not exceed 15mm. the max stress should not exceed 100 N/mm^2 $E=2 \times 10^5 \text{ N/mm}^2$ (8)
- 24 a.i) Calculate the max stress in a piece of rectangular steel strip 25mm wide and 3mm thick when it is bend round a drum, 2.5m diameter. $E= 2 \times 10^5 \text{ N/mm}^2$ (6)

- ii) Derive the relationship between the curvature slope and deflection of the beam. (6)
- (or)
- b.i) Enumerate the laws of static and dynamic friction. (8)
- ii) Explain the term friction? What is limiting friction? (4)
25. a) i) State the assumptions made in the derivation of the tension formula. (4)
- ii) A solid shaft has to transmit 10 kw at 210rpm. The max. torque transmitted is each revolution exceeds the mean by 30%. If the Shear stress is not to exceed 80 N/mm^2 . Find a suitable diameter of the solid shaft. Calculate the angle of twist for a length of 2 meters. $C=0.8 \times 10^5 \text{ N/mm}^2$ (8)
- (or)
- b) i) Distinguish between C closely coiled helical springs and an open coiled helical spring. (4)
- ii) Design a closely coiled spring of stiffness 20 N/mm deflection. The max. shear stress in the spring metal is not exceed 80 N/mm^2 under a load of 600 N. The diameter of the coil is to be 10 times the diameter of the wire. Take the modulus of Rigidity as 85 KN/mm^2 . (8)



DIPLOMA IN AUTOMOBILE ENGINEERING

L-SCHEME

2011-2012

22132 - AUTOMOBILE ENGINES

DIRECTORATE OF TECHNICAL EDUCATION

GOVERNMENT OF TAMILNADU

L-SCHEME
(Implements from the Academic year 2011-2012 onwards)

Course Name : DIPLOMA IN AUTOMOBILE ENGINEERING
Course Code : 1021
Subject Code : 22132
Semester : III
Subject Title : **AUTOMOBILE ENGINES**

TEACHING AND SCHEME OF EXAMINATIONS:

No. of Weeks per Semester: 16 Weeks

Subject	Instructions		Examination			Duration
	Hours/ Week	Hours/ Semester	Marks			
AUTOMOBILE ENGINES	6	96	Internal Assessment	Board Examination	Total	3 Hrs
			25	75	100	

TOPICS AND ALLOCATION OF MARKS

UNIT	TOPIC	TIME ALLOTTED (Hrs.)
I	Petrol Engines and Diesel Engine	18
II	Fuel feed system	18
III	Cooling and Lubrication systems	18
IV	Emission from Automobile	18
V	Emission control methods	18
	Assignment, Test & Revision	6
TOTAL		96

Rationale

Impart the knowledge on basic concepts on Automotive Petrol and Diesel Engines and its various sub components along with its function and to acquire knowledge about the automobile emissions and its control methods.

Objectives

- Learn the construction and working of petrol and diesel engines and its components.
- Learn the working principle of fuel feed system of petrol and diesel engines.
- Acquire the knowledge about the lubrication and cooling systems of automotive engines.
- Learn the various emissions in the automotive engines and its control methods.

AUTOMOBILE ENGINES

DETAILED SYLLABUS

Contents: Theory

UNIT	Name of the Topic	Hours
I	<p>PETROL ENGINES and DIESEL ENGINE</p> <p>Petrol Engines –Types of engines, straight, V, Square engine –Valve gear arrangements - types of valves – sodium cooled – Mushroom Valve – Crankshaft: Static balance and dynamic balance – torsional vibration dampers – analysis of performance of single and multi cylinder engines – Firing order 4, 6, & 8 – Detonation - Petrol Knock – Octane Number - Anti Knock Fuel.</p> <p>High Speed Diesel Engines — Combustion of Diesel fuel - phases of combustion in four stroke engines – diesel knock - Cetane Number – fuel dopes – Types of Diesel Engine Combustion chamber – open, pre combustion and turbulent chamber, air cell and energy cell combustion chamber in TATA and UNO engines – Petrol engine tune up.</p>	9 9
II	<p>FUEL FEED SYSTEM</p> <p>Petrol fuel feed systems – layout – construction and working of mechanical and Electrical Fuel feed pumps – Fuel filters - Multi Point Fuel Injection – Air filters : types – dry type, wet type and oil bath type. Carburetion – principles – Simple Carburetors – Solex Carburetor – S.U. Carburetor, Zenith, Mikuni Carburetor. Inlet & Exhaust manifolds - Mufflers and Silencers- DTSI, VTI, CCVTI, PGMFI-petrol injection-MPFI system necessity- merits and demerits.</p> <p>Diesel fuel feed system – Layout – Feed pump: single and double acting – FIP – jerk type & distributor type – Construction and operation – Diesel filter – Pre filter and Micro filter – Water separator – Injectors and Nozzles – Open type & Closed type, single & multi hole, pintle and pintex type nozzles. - Common Rail Direct Injection (CRDI) - Governors – Mechanical & Pneumatic type – Phasing & Calibration of fuel injection pumps – Injection timing – Testing of Injections. Super Charging – Its effect – Types of superchargers – Roots types, sliding vane and centralised types – Turbo chargers.</p>	9 9
III	<p>UNIT-III COOLING AND LUBRICATION SYSTEM</p> <p><i>Cooling system:</i> Air cooling system - water cooling system – Comparison – Thermo syphon and pump circulation in water cooling system – Open type and Closed type in water cooling system – Thermostat – Construction – wax pellet and Bellows type – Water pump – Radiators – Cellular and tubular – Coolant types - Anti Freeze solution.</p> <p><i>Lubrication System:</i> Splash - partial pressure system - Full flow and by pass systems – Characteristics of lubricating oils – classification & Identification of SAE oils – Filtering Systems — Oil Strainer – Oil pumps – Gear and Rotor type – Construction and operation -Pressure Relief Valve – Construction. Draft tube – Positive Crankcase Ventilation Systems – Construction. Vapour recovery cooling system Oil Cooler.</p>	9 9
IV	<p>UNIT-IV EMISSION FROM AUTOMOBILES</p> <p>Various emissions from Automobiles – formation – effects of pollutants on</p>	18

	environment and human beings – Emission formation in SI engines - carbon monoxide – unburnt hydrocarbon – Nitric oxide – Lead particulate – Ploy nuclear aromatic hydrocarbon emissions – Emission from C.I Engine – physical delay, chemical delay – significance – emission formation due to incomplete combustion – White, Blue and Black smokes – particulates – Noise pollution. Design and operating variables on emission formation.	
V	UNIT-V EMISSION CONTROL METHODS Emission norms – EURO, USA, JAPAN and INDIA. Controlling of pollutants from engine – catalytic converters – charcoat canister control for evaporative emission – positive crank case ventilation system for unburnt hydro carbon emission reduction – Fumigation EGR (Exhaust gas recirculation) – Air injection – silencer design on sound reduction in automobiles. – Exhaust gas analyser – Smoke meter.	18

Text Book

- 1 Internal Combustion Engines, "Ganesan.V", Tata-McGraw Hill Publishing Co., New Delhi 1994.
- 2 Internal Combustion Engines Theory and Practice, "Dr.K.K.Ramalingam", Scitech Publications(India) Pvt.Ltd, Chennai-17, 2001.
- 3 Engine Emission, "Springer and Patterson", Plenum Press, 1990.

Reference Book

- 1 Internal Combustion Engine analysis and Practice, "Obert.E.F" International Text Book Co., Scranton, Pennsylvania, 1988.
- 2 Internal Combustion Engine Fundamentals, "Heywood.J.B", McGraw Hill Book Co., 1995.
- 3 Internal Combustion Engines, "Taylor.C.F", MIT Press, 1972
- 4 Automobiles and Pollution SAE Transaction, 1995
- 5 SAE Transactions, " Vehicle emission ", 1982 (3 volumes).

22132 AUTOMOBILE ENGINES

MODEL QUESTION PAPER - I

Time: 3 Hrs

Max Marks : 75

PART A – Answer any fifteen questions. All Questions carry Equal marks. **15 x 1 = 15**

- 1 Mention the types of valves.
- 2 What is octane number?
- 3 What is pre combustion?
- 4 What is detonation?
- 5 List the components of fuel feed system.
- 6 Mention the types of filters.
- 7 What is the purpose of governor?
- 8 What is the effect of super charger?
- 9 Mention the types of coolant.
- 10 Mention the characteristics of lubricating oil.
- 11 Compare the water cooling and air cooling system.
- 12 Mention the different types of lubrication system.
- 13 What is the important effect for human being by the pollutants.
- 14 List the various emissions from automobiles.
- 15 What is physical delay?
- 16 What is chemical delay?
- 17 What are emission norms?
- 18 What is EGR?
- 19 What is AIR Injection
- 20 What is the use of catalytic converter?

PART B: Answer all questions.

5 x 12=60

- | | | |
|-------------|--|----|
| 21 A i | Mention the types of engines. | 2 |
| ii | Explain the construction of any two types of engine. | 10 |
| (OR) | | |
| B i | Describe briefly about catalytic converters. | 4 |
| ii | Explain the different types of combustion chamber. | 8 |
| 22 A i | What is carburetion? Mention the types of carburettor. | 4 |
| ii | Explain the construction and working of S U carburettor. | 8 |
| (OR) | | |
| B i | Draw the layout of Diesel fuel feed system. | 4 |
| ii | Explain the working of Common Rail Direct Injection system. | 8 |
| 23 A i | Describe about open type and closed type in water cooling system. | 4 |
| ii | Explain the construction and working of pump circulation water cooling system. | 8 |

(OR)

B	i	Describe about crankcase ventilation system.	4
	ii	Explain the construction and working of Gear and rotor type pump.	8
24 A	i	Explain the various emission formation in SI engines	12
(OR)			
B	I	Write briefly about the design and operating variables on emission formation.	5
	ii	Explain the emission formation due to incomplete combustion.	7
25 A	i	Explain the crankcase ventilation	5
	ii	Explain the different methods used for controlling pollution from vehicles.	7
(OR)			
B	i	Explain the construction of catalytic converter.	4
	ii	Describe the exhaust gas recirculation for emission control.	8

22132 AUTOMOBILE ENGINES

MODEL QUESTION PAPER - II

Time: 3 Hrs

Max Marks : 75

PART A – Answer any fifteen questions. All Questions carry Equal marks. **15 x 1 = 15**

- 1 What is use of crank shaft?
- 2 What is diesel knock?
- 3 What is air cell?
- 4 What is firing order?
- 5 List the types of air filters.
- 6 Mention the types of nozzles.
- 7 What is the carburetion?
- 8 What is the effect of turbo charger?
- 9 Compare air cooling with water cooling system.
- 10 What is thermostat?
- 11 What is the purpose of radiator?
- 12 What is anti freeze solution?
- 13 What are the important effect pollutants on environment?
- 14 List the various emissions from SI engine.
- 15 What is noise pollution?
- 16 Why black smoke occurs?
- 17 State the INDIAN emission norms.
- 18 What is smoke meter?
- 19 What is EGR?
- 20 What is catalytic converter?

PART B: Answer all questions.

5 x 12=60

- 21 A i Mention the types of valves. 2
ii Explain the construction of any two types of valves. 10

(OR)

- B i Describe briefly about combustion of diesel fuel. 4
ii Explain the different phases of combustion in four stroke engines. 8
- 22 A i Explain the construction and working of Mechanical and Electrical fuel feed pump. 12

(OR)

- B i Write briefly about the calibration of fuel injection pumps. 4
ii Explain the working of different types of governors. 8
- 23 A i Describe about the bellow type thermostat. 4
ii Explain the construction and working of thermo syphon water cooling system. 8

(OR)

- B i Explain the construction of pressure relief valve. 4

	ii	Explain the construction and working of full flow lubrication system.	8
24 A	i	Explain the various emission formation in CI engines	12
		(OR)	
B	i	Explain the effects of pollutants.	12
25 A	i	Explain the silencer design on sound reduction.	5
	ii	Explain the charcoal canister control for evaporative emission.	7
		(OR)	
B	i	Explain the construction of catalytic converter.	4
	ii	Explain the working of smoke meter.	8



DIPLOMA IN AUTOMOBILE ENGINEERING

L-SCHEME

2011-2012

**22133 - AUTOMOBILE CHASSIS AND
TRANSMISSION**

**DIRECTORATE OF TECHNICAL EDUCATION
GOVERNMENT OF TAMILNADU**

L-SCHEME
(Implements from the Academic year 2011-2012 onwards)

Course Name : DIPLOMA IN AUTOMOBILE ENGINEERING
Course Code : 1021
Subject Code : 22133
Semester : III
Subject Title : **AUTOMOBILE CHASSIS AND TRANSMISSION**

TEACHING AND SCHEME OF EXAMINATIONS:

No. of Weeks per Semester: 16 Weeks

Subject	Instructions		Examination			Duration
	Hours/ Week	Hours/ Semester	Marks			
AUTOMOBILE CHASSIS AND TRANSMISSION	5	80	Internal Assessment	Board Examination	Total	3 Hrs
			25	75	100	

TOPICS AND ALLOCATION OF MARKS

UNIT	TOPIC	TIME ALLOTTED (Hrs.)
I	CHASSIS, FRAME , BODY AND AXLE	15
II	CLUTCH and GEAR BOX	15
III	UNIVERSAL JOINT, PROPELLER SHAFT, DIFFERENTIAL	15
IV	STEERING SYSTEM and SUSPENSION SYSTEM	15
V	BRAKES AND TYRES	15
	Assignment, Test & Revision	5
TOTAL		80

RATIONALE

Impart knowledge about the chassis structure of an automobile vehicle. To acquire knowledge about the systems and its functions of the components assembled with the chassis. Understand about the transmission system and its components of an automobiles.

OBJECTIVES

- To learn the types of chassis and axles.
- To study about the steering system and its methods.
- To understand the suspension systems and its components.
- To learn the functions of universal joint and propeller shafts.
- To study working principle of differential unit.
- To learn about the types of brakes and tyres.
- To know the function of clutch and gear box and its types.

AUTOMOBILE CHASSIS AND TRANSMISSION
DETAILED SYLLABUS

Contents: Theory

UNIT	Name of the topic	Hours
I	CHASSIS, FRAME , BODY AND AXLE Introduction of Chassis frame - Layout of the Chassis and its main components - Functions of the Chassis frame - Types of Chassis frames - Various loads acting on the frame – different bodies used in automobiles - requirements of bodies for various types of vehicles viz. private, commercial etc. Front axle construction – live and dead axle – beam and tubular construction – stub axle types – Elliot and reverse Elliot – Lemoine and Lemoine inverted – rear axle construction — floating axles – semi-floating – three quarter floating and full floating.	8 7
II	CLUTCH and GEAR BOX Clutch – function – clutch actuating mechanism – Mechanical and hydraulic types – clutch material – single plate dry clutch – dual plate dry clutch – multi plate wet clutch – semi centrifugal and centrifugal clutch – motor cycle clutch – fluid coupling – Trouble shooting of Clutch. Gear Box – purpose – resistance offered to the motion of the vehicle – air resistance – rolling resistance – offered to the motion of the vehicle – gradient resistance – tractive effort – effect of gear ratio on fuel consumption – types of gear boxes – sliding mesh – constant mesh – synchromesh device – epicyclic – over drive – under drive and transfer cases – 4 wheel drive – gear shifting mechanism – floor shifting and steering column shifting – mechanical and hydraulic control systems – variator – Trouble shooting of gear box.	7 8
III	UNIVERSAL JOINT, PROPELLER SHAFT, DIFFERENTIAL Universal Joints – variable velocity joint – constant velocity joints – cross or spider type – Rzeppa joints – Bendix Weiss type – tracta – centre joint – construction for heavy vehicles – propeller shaft two piece and three piece construction– Hotchkiss, torque tube, Torque arms – Shackles types - final drive-function – types – Spiral, bevel, Hypoid – worm and worm wheel – Differential function – differential action – non slip differential – differential lock – – Trouble shooting of final drive and differential.	15
IV	STEERING SYSTEM and SUSPENSION SYSTEM Steering system – Ackerman principle of steering – front end geometry – castor, camber, king pin inclination, toe-in, toe-out on turns – steering gear box – types – Marles cam and roller – cam and peg – recirculating ball – rack and pinion – power steering, linkage booster type, integral type – power steering pumps. Suspension system – rigid axle and independent suspension – function of spring and shock absorber – independent suspension – coil, leaf spring, torsion bar (solid and laminated leaf spring types) and air suspension – rear independent suspension antiroll bar – principle of knee action — shock absorbers – direct acting indirect acting – Telescopic type – Air suspension systems – Trouble shooting in suspension & steering systems.	7 8
V	BRAKES AND TYRES Brakes – function – stopping distance – Braking system – mechanical, hydraulic and air brake systems – brake shoes, primary and secondary shoes – servo action of brake shoes – drum and disc brakes – construction and operation –	8

	master cylinder – single and Tandem master cylinder – wheel cylinders – bleeding of brakes – brake shoe adjustment mechanism – Micram adjusters – Snailcam, screw adjuster. Tyres and tubes – cross ply and radial ply – tubeless tyres – wheels – types – disc, split type, spoked and magna – purpose of tandem rear axle – trouble shooting of braking system and tyres – power brakes – Air and Air assisted Brake systems-Anti lock brake system(ABS)- Anti Skid devices(ASD)	7
--	---	---

Text Book

- 1 Automotive Transmission & Power Train – William H. Grouse.
- 2 Automotive Chassis and Body-William H. Grouse
- 3 Modern Transmission systems, Judge, A.W., Chapman and Hall Ltd., 1990.

Reference Book

- 1 Automobile Transmission Volume II – A.W.Judge.
- 2 Automotive Chassis, Heldt P.M., Chilton Co., New York, 1990
- 3 Motor Vehicles, Newton Steeds and Garret, 13th Edition, Butterworth, London, 2005.
- 4 Automobile engineering vol I – Dr.kirpal singh – standard publishers – 10 th edition 2007.
- 5 Passenger Car Automotive Transmissions”, Design Practices, SAE Hand book- 1994.
- 6 Automotive Transmission and Power Trains construction, Crouse, W.H., Anglin, D.L., McGraw Hill, 1992.

22133 AUTOMOBILE CHASSIS AND TRANSMISSION

MODEL QUESTION PAPER- I

Time: 3 Hrs

Max Marks : 75

PART A – Answer any fifteen questions. All Questions carry Equal marks. **15 x 1 = 15**

- 1 What is the function of the chassis frame?
- 2 Mention the various loads acting on the frame.
- 3 Mention the types of chassis frame,
- 4 What is dead axle?
- 5 What are the clutch materials?
- 6 What is purpose of gear box?
- 7 What is four wheel drive?
- 8 What is the effect of gear ratio on fuel consumption?
- 9 What is universal joint?
- 10 Mention the function differential.
- 11 What is the use of shackle?
- 12 What is torque tube?
- 13 What is camber?
- 14 What is power steering?
- 15 Mention the types of gears used in the steering system.
- 16 What is air suspension?
- 17 What is function of brake?
- 18 What is wheel cylinder?
- 19 Mention the purpose of snail cam.
- 20 What is ABS?

PART B: Answer all questions.

5 x 12=60

- | | | | | |
|------|----|--|--|----|
| 21 A | i | Explain the construction of different layout of the chassis. | 12 | |
| | | (OR) | | |
| | B | i | Describe about the front axle. | 4 |
| | | ii | Explain the constructional details and operation of Elliot and reverse Elliot. | 8 |
| 22 A | i | Describe about fluid coupling. | 4 | |
| | ii | Explain the working principle of multi plate clutch.. | 8 | |
| | | (OR) | | |
| | B | i | Explain construction and working of synchromesh gear box. | 12 |
| 23 A | i | Explain construction of different propeller shaft. | 7 | |
| | ii | Write briefly about tractive effort. | 5 | |
| | | (OR) | | |
| | B | i | Explain the construction and working of differential unit. | 12 |
| 24 A | i | Explain the different gear arrangement for steering. | 12 | |
| | | (OR) | | |
| | B | i | Explain the trouble shooting of final drive and differential. | 12 |
| 25 A | i | Explain the working of air brake system with a layout. | 12 | |
| | | (OR) | | |
| | B | i | Explain about the construction of different types of tyres. | 12 |

22133 AUTOMOBILE CHASSIS AND TRANSMISSION

MODEL QUESTION PAPER- II

Time: 3 Hrs

Max Marks : 75

PART A – Answer any fifteen questions. All Questions carry Equal marks. **15 x 1 = 15**

- 1 What is floating axle?
- 2 Mention the requirement of body.
- 3 List the main components of chassis.
- 4 What is live axle?
- 5 What is the function of clutch?
- 6 What is tractive effort?
- 7 What is air resistance?
- 8 What is the effect of gear ratio on fuel consumption?
- 9 What is Rzeppa joint?
- 10 Mention the function final drive.
- 11 What is differential lock?
- 12 What is torque tube?
- 13 What is castor?
- 14 What is toe in and toe out?
- 15 Mention the function of shock absorber.
- 16 What is the use of antiroll bar?
- 17 What is stopping distance?
- 18 Mention the types of wheels.
- 19 Mention the purpose of tandem rear axle.
- 20 What are the troubles of tyres.

PART B: Answer all questions.

5 x 12=60

- | | | | |
|-------------|----|--|----|
| 21 A | i | Distinguish between semi floating and full floating rear axles. | 4 |
| | ii | Explain the construction of different floating axles. | 8 |
| (OR) | | | |
| B | i | Describe the function of the chassis frame. | 4 |
| | ii | Explain the constructional details and operation of various front axle arrangements. | 8 |
| 22 A | i | Explain the construction and working of semi centrifugal and centrifugal clutch. | 12 |
| (OR) | | | |
| B | i | Explain the working of steering column gear shifting mechanism. | 6 |
| | ii | Explain the trouble shooting of gear box. | 6 |
| 23 A | i | Explain the working of non slip differential. | 7 |
| | ii | Explain the bendix weiss type joint. | 5 |
| (OR) | | | |
| B | i | Write briefly about shackles. | 3 |
| | ii | Explain the trouble shooting of final drive and differential. | 9 |
| 24 A | i | Describe about front end geometry. | 4 |
| | ii | Explain the Ackerman principle of steering. | 8 |
| (OR) | | | |
| B | i | Write briefly about the telescopic type shock absorber. | 6 |
| | ii | Explain the independent suspension system. | 6 |
| 25 A | i | Explain the construction and operation of master cylinder. | 8 |
| | ii | Explain about the wheel cylinders. | 4 |
| (OR) | | | |
| B | i | Explain about the construction of different types of tyres. | 6 |
| | ii | Explain the working principle of anti lock brake system. | 6 |



DIPLOMA IN AUTOMOBILE ENGINEERING

L-SCHEME

2011-2012

22034 - MACHINE DRAWING

DIRECTORATE OF TECHNICAL EDUCATION

GOVERNMENT OF TAMILNADU

L-SCHEME
(Implements from the Academic year 2011-2012 onwards)

Course Name : DIPLOMA IN AUTOMOBILE ENGINEERING
Course Code : 1021
Subject Code : 22034
Semester : III
Subject Title : **MACHINE DRAWING**

TEACHING AND SCHEME OF EXAMINATIONS:

No. of Weeks per Semester : 16 Weeks

Subject	Instructions		Examination			Duration
	Hours/ Week	Hours/ Semester	Marks			
Machine Drawing	6	96	Internal Assessment	Board Examination	Total	3 Hrs
			25	75	100	

Topics and Allocation of Hours:

Unit No	Topics	Hours
I	Sectional Views	3
II	Limits, Fits and Tolerances	6
III	Surface Texture	3
IV	Keys, Screw threads and Threaded fasteners	6
V	Drawing practice of sleeve & Cotter joint, Spigot and cotter joint, Knuckle joint, Stuffing Box , Screw Jack, Foot step bearing, Universal Coupling, Plummer Block, Swivel Bearing, Simple Eccentric, Machine Vice, Protected type flanged coupling, Connecting Rod, Tail Stock – Manual Drawing Practice	75
	Revision and Test	3
	Total	96

RATIONALE:

Manufacturing of various machine parts and production of various equipments in small scale to big scale industries start from the basic drawing of components. The assembly of components is also carried out from the drawing. So drawing is an important subject to be studied by supervisor cadre students to carry and complete the production and assembly process successfully.

The first three are theory units in which the students can comprehend the various types of sections used in drawing practice. Types of fits used, limits and tolerances of dimensions and surface finish methods which are to be used in industrial drawing will also be taught in these three units.

The fourth unit is also a theory unit in which the students can understand the types of fasteners and study of temporary fasteners like keys, screw threads and threaded fasteners which are commonly used in assembly process.

The final unit gives the practice of manual drawing of the commonly used components in industries to give a thorough knowledge of drawings.

The overall objective is to impart knowledge to the students so as to carry out the production and the assembly process without wastage of Man/Machine and Materials to have economical overall process.

OBJECTIVES:

- Appreciate the need for sectional view and types of sections.
- Draw sectional views using different types of sections.
- Explain the use of threaded fasteners and the types of threads.
- Compare hole basis system with shaft basis system.
- Select different types of fits and tolerance for various types of mating parts.
- Appreciate the importance of fits and tolerance.

MACHINE DRAWING
DETAILED SYLLABUS

Contents: Theory

Unit	Name of the Topic	Hours
I	SECTIONAL VIEWS Review of sectioning – Conventions showing the section – symbolic representation of cutting plane- types of section – full section, half section, offset section, revolved section, broken section, removed section – section lining.	3 Hrs
II	LIMITS, FITS AND TOLERANCES Tolerances – Allowances – Unilateral and Bilateral tolerances. Limits – Methods of tolerances – Indication of tolerances on linear dimension of drawings – Geometrical tolerances – application – Fits – Classifications of fits – Selection of fits – examples	6 Hrs
III	SURFACE TEXTURE Surface texture – importance – controlled and uncontrolled surfaces – Roughness – Waviness – lay – Machining symbols	3 Hrs
IV	KEYS, SCREW THREADS AND THREADED FASTENERS Types of fasteners – temporary fasteners – keys – classification of keys – Heavy duty keys – light duty keys. Screw thread – Nomenclature – different types of thread profiles – threads in sections – threaded fasteners – bolts – nuts – through bolt – tap bolt, stud bolt – set screw – cap screws – machine screws – foundation bolts	6 Hrs
V	MANUAL DRAWING PRACTICE Detailed drawings of following machine parts are given to students to assemble and draw the sectional or plain elevations / plans / and side views with dimensioning and bill of materials <ol style="list-style-type: none"> 1. Sleeve & Cotter joint 2. Spigot & Cotter joint 3. Knuckle joint 4. Stuffing Box 5. Screw Jack 6. Foot step bearing 7. Universal Coupling 8. Plummer Block 9. Swivel Bearing 10. Simple Eccentric 11. Machine Vice 12. Protected type flanged coupling 13. Connecting Rod 14. Tail Stock 	75 Hrs

Reference Books:

- 1) Machine Drawing, P.S. Gill, Katsan Publishing House, Ludiana
- 2) A Text book of Engineering Drawing, R.B. Gupta, Satya Prakasan, Technical India Publications, NewDelhi
- 3) Mechanical Draughtsmanship, G.L. Tamta, Dhanpat Rai & Sons, Delhi
- 4) Geometrical and Machine Drawing, N.D. Bhatt, Cheroter book stalls, Anand, West Railway
- 5) Engineering Drawing, D.N. Ghose, Dhanpat Rai & Sons, Delhi

22034 MACHINE DRAWING
MODEL QUESTION PAPER-1

Time: 3 Hrs

Max Marks : 75

Part A & Part B to be answered in Drawing sheet

PART A

4 x 5= 20

Theory questions:

Answer any four questions

1. Name different types of section. Explain with example full section and half section.
2. Define Hole basis and shaft basis system. Explain with sketch.
3. Name different types of fits. Draw the tolerance zone for defining those fits.
4. Indicate roughness grade symbol for N10.
5. Illustrate the types of keys. Draw a gib headed key with its proportions.

PART B : 55 Marks

1. Assemble and Draw the following views of stuffing box (Detailed drawing given)

Right half sectional elevation	:	30
Plan	:	20
Bill of Material	:	5

22034 MACHINE DRAWING
MODEL QUESTION PAPER – II

Time: 3 Hrs

Max Marks : 75

PART – A

Marks 4 x 5 = 20

Answer any 5

1. What is the need for sectioning? Explain broken section and revolved section with neat sketch.
2. why hole basis system is preferred over shaft basis system? Explain with suitable eg & sketch.
3. Define i) Lay
ii) Waviness with suitable sketch. Draw conventional symbol for mentioning surface finish.
4. State the conventions followed in representing threads in drawings. Draw the representation for internal and external threads.
5. Draw 3 views of square nut of diameter 60 mm with proper formulae.

PART – B

II Assemble and draw the below mentioned views of SCREW JACK

Right Half sectioned elevation	30
Plan	20
Bill of Material	5



DIPLOMA IN AUTOMOBILE ENGINEERING

L-SCHEME

2011-2012

**22035 - MECHANICAL TESTING & QUALITY
CONTROL PRACTICAL**

**DIRECTORATE OF TECHNICAL EDUCATION
GOVERNMENT OF TAMILNADU**

L-SCHEME

(Implements from the Academic year 2011-2012 onwards)

Course Name : DIPLOMA IN AUTOMOBILE ENGINEERING
Course Code : 1021
Subject Code : 22035
Semester : III
Subject Title : **MECHANICAL TESTING & QUALITY CONTROL PRACTICAL**

TEACHING AND SCHEME OF EXAMINATIONS:

No. of Weeks per Semester : 16 Weeks

Subject	Instructions		Examination			Duration
	Hours/Week	Hours/Semester	Marks			
Mechanical Testing & Quality control Practical	4	64	Internal Assessment	Board Examination	Total	3 Hrs
			25	75	100	

OBJECTIVES:

- Acquire skills on different types of testing methods of metals.
- Conduct material testing on elasticity, hardness, bending, shear strength
- Acquire knowledge in microstructure of the metals.
- Prepare the metal for microscopic view.
- Conduct non-destructive testing methodology to find fine cracks and flaws etc.
- Determine modules of rigidity of open spring and closed coil springs.

Note:

The students should be given training in both sections. All the exercises should be completed. The students should maintain record notebook for the concerned subjects and submit during the Board Practical Examinations.

A. MECHANICAL TESTING

Determine stress strain relations for steel.
Determine hardness of materials.
Perform torsion, bending, impact and shear tests.

Exercises**1. Test on Ductile Materials:**

Finding Young's Modulus of Elasticity, yield points, percentage elongation and percentage reduction in area, stress strain diagram plotting, tests on mild steel.

2. Hardness Test:

Determination of Rockwell's Hardness Number for various materials like mild steel, high carbon steel, brass, copper and aluminium.

3. Torsion test:

Torsion test on mild steel – relation between torque and angle of twist-determination of shear modulus and shear stress.

4. Bending and deflection tests:

Determination of Young's Modulus for steel by deflection test.

5. Impact test:

Finding the resistance of materials to impact loads by Izod test and Charpy test.

6. Tests on springs of circular section:

Determination of modulus of rigidity, strain energy, shear stress and stiffness by load deflection method (Open & Closed coil spring)

7. Shear test:

Single or double Shear test on M.S. bar to finding the resistance of material to shear load.

B. QUALITY CONTROL

To study the microscope structure of the metals

Determine the microscope structure of the ferrous and nonferrous metals

Conduct the liquid penetration test to find crack

Conduct magnetic particle test to find cracks

Exercise

1. Using the Metallurgical microscope and identify the grain structure of given specimen.
2. Preparation of specimen to examine the micro structure of metal samples (i) Ferrous and (ii) Non-Ferrous (Minimum two exercises on each category).
3. Detection of Cracks in casting using Visual Inspection and ring test & Die penetrant test
4. Detection of Cracks in casting using Magnetic particle test.

BOARD EXAMINATION

Note: All the exercises should be given in the Board Examination and students are allowed to select by a lot

Exercises	Duration	Max. Marks
A. Mechanical Testing	2 Hrs	45
Observation/tabulation		15
Reading/calculation		20
Result/Graph		10
B. Quality control	1 Hrs	25
Specimen preparation		10
View /Exercise		10
Result		5
Viva-voce		5
TOTAL		75

LIST OF EQUIPMENTS

S.No	LIST OF THE TOOLS &EQUIPMENTS	QUANTITY REQUIRED
1.	UTM	01
2.	Rockwell's Hardness Testing Machine	01
3.	Torsion testing machine	01
4.	Deflection testing arrangement	01
5.	Impact testing machine	01
6.	Tension testing arrangements	01
7.	Shear testing machine	01
8.	Vernier calliper	02
9.	Metallurgical Microscope	06
10.	Sample Specimen for ferrous & non- ferrous (Identification)	06 each
11.	For LPT	
	a. Die	02 no's
	b. Cleaner	04 no's
	c. Developer	04 no's
12.	Magnetic particle test equipment	02 no's
13.	Belt polishing machine	01
14.	Lapping machine	01
15.	Sample Specimen	10 no's



DIPLOMA IN AUTOMOBILE ENGINEERING

L-SCHEME

2011-2012

**22136 - AUTOMOBILE CHASSIS AND TRANSMISSION
PRACTICAL**

**DIRECTORATE OF TECHNICAL EDUCATION
GOVERNMENT OF TAMILNADU**

L-SCHEME
(Implements from the Academic year 2011-2012 onwards)

Course Name : DIPLOMA IN AUTOMOBILE ENGINEERING
Course Code : 1021
Subject Code : 22136
Semester : III
Subject Title : **AUTOMOBILE CHASSIS AND TRANSMISSION PRACTICAL**

TEACHING AND SCHEME OF EXAMINATIONS:

No. of Weeks per Semester : 16 Weeks

Subject	Instructions		Examination			Duration
	Hours/ Week	Hours/ Semester	Marks			
Automobile Chassis and Transmission Practical	4	64	Internal Assessment	Board Examination	Total	3 Hrs
			25	75	100	

Note: All the experiments should be conducted. Two questions will be given by selecting one question from each part. **Necessary safety arrangement to be made to lift and carryout the experiments. The components should be fixed in the frame / table as per the requirement.**

Part A

1. Remove and replace the pressure plate and clutch plate, fingers adjustment and clutch plate relining.
2. Dismantle, inspect and assemble the sliding mesh gear box / constant mesh gear box to find the gear ratios.
- 3 Dismantle, inspect and assemble the synchromesh gear box / Epicyclic gear train to find the gear ratios.
4. Dismantle and assemble the rear axle and adjust wheel bearing.
5. Dismantle, assemble and adjust the steering gearbox and find gear ratio.
6. Dismantle, assemble and adjust the power steering.
7. Dismantle, inspect and assemble the final drive and differential units.

Part B

8. Remove, inspect and refit the shock absorber.
9. Dismantle and assemble the leaf and coil spring.
10. Overhauling, adjusting and bleeding of Hydraulic system.
11. Remove the tyre for Valcanizing the tubes and refix.
12. Wheel alignment: four-wheel drive mechanism.
13. Wheel balancing: check, measure and adjust the castor, camber, king pin inclination, toe-in and toe-out.

BOARD EXAMINATION - DETAILED ALLOCATION

Note: Question paper should have two questions one from each part.

PART A	30
PART B	40
Viva voice	5
Board Examination	75
Internal mark	25
Total	100

Resources required

Minimum requirement for the sixty intakes. Based on the intake the facility should be improved.

For each experiment separate components are required.

- Valcanizing kit – 2 Nos.
- Four Wheel alignment kit – 1 No.
- Wheel balancing device – 1No.
- Mechanical / Hydraulic Press -1 no.
- Hydraulic brake system fixed in the frame – 2 Nos.
- Screw jack / Hydraulic jack - 2 nos.
- Hoist – 2 nos.
- Trolley – 2nos.
- Spanners & Tools – 6 sets



DIPLOMA IN AUTOMOBILE ENGINEERING

L-SCHEME

2011-2012

20001 - COMPUTER APPLICATIONS PRACTICAL

DIRECTORATE OF TECHNICAL EDUCATION

GOVERNMENT OF TAMILNADU

L-SCHEME
(Implements from the Academic year 2011-2012 onwards)

Course Name : COMMON TO ALL BRANCHES
Course Code : 1020
Subject Code : 20001
Semester : III
Subject Title : **COMPUTER APPLICATIONS PRACTICAL**

TEACHING AND SCHEME OF EXAMINATIONS:

No. of Weeks per Semester : 16 Weeks

Subject	Instructions		Examination			
	Hours/ Week	Hours/ Semester	Marks			Duration
Computer Applications Practical	4	64	Internal Assessment	Board Examination	Total	3 Hrs
			25	75	100	

RATIONALE:

The application of Computer knowledge is essential to the students of all disciplines of Engineering in addition to their respective branch of study. The Computer Application Practical course facilitates the necessary knowledge and skills regarding creating, working and maintaining the documents, analyzing the data with charts manipulation of databases and presentation of documents with audio visual effects in a computer.

The learning of internet provides students with unprecedented opportunities to obtain information engage in discussion and liaise with individuals, organizations and groups world-wide. It provides the latest tools and technologies in helping the students to fetch better employment.

OBJECTIVES:

On completion of the following exercises, the students must be able to

- Understand the Windows operating systems
- Familiarize and customize the desktop
- Use the different facilities available in the word processor
- Analyze the data sheet
- Create and manipulate the database
- Prepare PowerPoint presentation
- Understand Internet concepts and usage of e-mail

GUIDELINES:

- All the eighteen experiments given in the list of experiments should be completed and all the experiments should be included for the end semester practical examination.
- The end semester practical examination question paper contains two questions-the first question from section-I and the second question from section-II. Each question carries 35 marks and viva voce carries 5 marks.
- The computer systems should be 1:2 ratio for practical classes

ALLOCATION OF MARKS

1. Internal Assessment – 25 Marks

DESCRIPTION	MARKS ALLOTTED
Record with Printout	10
Assignment	5
Attendance	5
Model Examination	5
Total	25 MARKS

2. Board Examinations – 75 Marks

Content	Max. Marks	
	Section I	Section II
Writing steps	15	15
Execution of exercise	15	15
Result with Printout	5	5
Viva voce	5	
Total	75 Marks	

LAB EXERCISES

SECTION – I

WINDOWS

Introduction- History of Windows- screen saver and monitor resolution – Wallpaper setting- Folder manipulation – properties of a folder – Recycle bin – Short cuts – Sorting Folder – Switching between Application – Copying in CD/DVD settings – Recording Audio files.

Exercises

1.
 - a. Installing screen saver and change the monitor resolution by 1280X960
 - b. Setting wall papers
 - c. Creating, moving, deleting and renaming a folder
 - d. Copy, paste and cut a folder/file
 - e. Displaying the properties for a file or folder
2.
 - a. Restoring files and folders from Recycle bin
 - b. Creating short cuts for folder/file
 - c. Finding a file or folder by name
 - d. Selecting and moving two or more files/folders using mouse
 - e. Sorting folders/files.
3.
 - a. Copying files into CD/DVD
 - b. Switching between applications
 - c. Making the taskbar wider and hiding the taskbar
 - d. Recording and saving an audio file
 - e. Set/Change the date and time.

WORD PROCESSING

Introduction – Menus – Tool bar – Create – Edit – Save – Alignment – Font Size – Formatting – Tables – Fill Colors – Mail Merge – Page Setup - Preview – Water marking – Header – Footer – Clip art.

Exercises

4. Create the following table and perform the operations given below

ABC PVT. LTD.

Chennai

Production Summary of various Units in every Quarter

Unit	Product - ID	Jan-Mar	Apr-june	July-Sept.	Oct-Dec.
Unit - I	56	234.	50	74	125
Unit - II	142	236	126	175	251
Unit - III	213	541	216	60	43
Unit - IV	125	243	127	250	136
Unit - V	143	152	138	80	45

- Arrange Unit name as left align and other columns as right align.
- Use doubled Border to the Summary Title and fill with 15% gray colour.
- Implement merging and splitting two or more cells
- Give alternative fore colour for columns.
- Print the above table.

5. Create a standard covering letter and use mail merge to generate the customized letters for applying to a job in various organizations. Also, create a database and generate labels for the applying organizations.
6. Create a news letter of three pages with two columns text. The first page contains some formatting bullets and numbers. Set the document background colour and add 'confidential' as the watermark. Give the document a title which should be displayed in the header. The header/ footer of the first page should be different from other two pages. Also, add author name and date/ time in the header. The footer should have the page number.

SPREADSHEET

Introduction – Menus – Tool bar – Create – Edit – Save – Formatting cells – Chart wizard – Fill Colors – Creating and using formulas – Sorting – Filtering.

Exercises

7. Create a result sheet containing Candidate's Register No., Name, Marks for six subjects. Calculate the total and result. The result must be calculated as below and failed candidates should be turned to red.
 - Result is Distinction if Total ≥ 70 %
 - First Class if Total ≥ 60 % and < 70 %
 - Second Class if Total ≥ 50 % and < 60 %
 - Pass if Total ≥ 35 % and < 50 %
 - Fail otherwise
 Create a separate table based on class by using auto filter feature.
8. Create a table of records with columns as Name and Donation Amount. Donation amount should be formatted with two decimal places. There should be at least twenty records in the table. Create a conditional format to highlight the highest donation with blue colour and lowest donation with red colour. The table should have a heading.
9. Prepare line, bar and pie chart to illustrate the subject wise performance of the class for any one semester.

SECTION – II

DATABASE

Introduction – Menus – Tool bar – Create – Edit – Save – Data types – Insert – Delete – Update – View – Sorting and filtering – Queries – Report – Page setup – Print.

Exercises

10. Create Database to maintain at least 10 addresses of your class mates with the following constraints

- Roll no. should be the primary key.
- Name should be not null

11. Prepare a payroll for employee database of an organization with the following details:

Employee Id, Employee name, Date of Birth, Department and
Designation, Date of appointment, Basic pay, Dearness Allowance,
House Rent Allowance and other deductions if any.
Perform simple queries for different categories.

12. Design a pay slip for a particular employee from the above database.

PRESENTATION

Introduction – Menus – Tool bar – Create – Edit – Save – Slide transition – Insert image – Hyper link – Slide numbers – View slide show with sound – Photo album – Clip art.

Exercises

13. Make a marketing presentation of any consumer product with at least 10 slides. Use different customized animation effects on pictures and clip art on any four of the ten slides.
14. Create a Presentation on “Communication Skills” with three different slide transitions with sound effect.
15. Create a photo album in PowerPoint.

INTERNET

Introduction – Browsers – Open a website – Email: Send, receive and delete – Email with Attachments
Google docs – Search Engines – Searching topics

Exercises

16. Create an e-mail id and perform the following
- Write an e-mail inviting your friends to your Birthday Party.
 - Make your own signature and add it to the e-mail message.
 - Add a word attachment of the venue route
 - Send the e-mail to at least 5 of your friends.

17. Create a presentation on Google docs. Ask your friend to review it and comment on it. Use “Discussion” option for your discussions on the presentation.
18. Find out the direction and distance about road travel from Delhi to Agra using the Internet search. Also make a report of the Map and other details like place to stay and visit at Agra.

MODEL QUESTION PAPER

Year / Sem: II / III	Subject: COMPUTER APPLICATIONS PRACTICAL	Code: 20001
Answer all the questions		Max.Marks:75
1	<p><u>Section - I</u></p> <p>Prepare line, bar and pie chart to illustrate the subject wise performance of the class for any one semester.</p>	
2	<p><u>Section - II</u></p> <p>Create an e-mail id and perform the following</p> <ul style="list-style-type: none"> Write an e-mail inviting your friends to your Birthday Party. Make your own signature and add it to the e-mail message. Add a word attachment of the venue route Send the e-mail to at least 5 of your friends. 	

LIST OF EQUIPMENTS AND THE QUANTITY REQUIRED FOR A BATCH OF 30 STUDENTS

SOFTWARE REQUIREMENTS

Operating System	Windows XP or Windows Vista or Windows 7 / Linux
Office Package	Microsoft office 2000 or Office 2003 or Office 2007/Open Office

HARDWARE REQUIREMENTS

Desktop Computer System with latest configuration	30 Nos
Power Backup (UPS)	10 KVA
Laser Printer	3 Nos

SAFETY PRECAUTIONS TO BE FOLLOWED BY STUDENTS

- Do not touch, connect or disconnect any plug or cable without teacher’s permission
- Don’t attempt to touch any live wires
- Systems should be shutdown properly after completion of work

REFERENCES

TITLE	AUTHOR	PUBLISHER	Year of Publication
Computer Applications Practical Manual	Dr.V.Karthikeyan Mr.D.Arulsevan	Learning Resource Centre, Thiagarajar Polytechnic College, Salem- 636 005	2012
Windows 7 in easy steps	Harshad kotecha	Tata McGrawHill	2011
A First Course in Computer 2003	Sanjay Sasena	Vikas Publications	2009
MS Office – 2003	Ramesh Bangia	Kanna Book Publication	2005
Introduction to Computers with MS-Office 2000	Alexis Leon & Mathews Leon	Tata McGraw-Hill	2002
Mastering Microsoft Office 2000	Gini Courter & Annette Marquis	BPB Publications	1999

IV SEMESTER



DIPLOMA IN AUTOMOBILE ENGINEERING

L-SCHEME

2011-2012

22041 - MANUFACTURING TECHNOLOGY - I

DIRECTORATE OF TECHNICAL EDUCATION

GOVERNMENT OF TAMILNADU

L-SCHEME
(Implements from the Academic year 2011-2012 onwards)

Course Name : DIPLOMA IN AUTOMOBILE ENGINEERING
Course Code : 1021
Subject Code : 22041
Semester : IV
Subject Title : **MANUFACTURING TECHNOLOGY - I**

TEACHING AND SCHEME OF EXAMINATIONS:

No. of Weeks per Semester : 16 Weeks

Subject	Instructions		Examination			
	Hours/ Week	Hours/ Semester	Marks			Duration
Manufacturing Technology - I	5	80	Internal Assessment	Board Examination	Total	3 Hrs
			25	75	100	

Topics and Allocation of Hours:

Unit No	Topics	Hours
I	CASTING PROCESSES	15
II	JOINING PROCESSES	15
III	BULK DEFORMATION PROCESSES AND HEAT TREATMENT	15
IV	MANUFACTURING OF PLASTIC COMPONENTS AND POWDER METALLURGY	15
V	CENTRE LATHE AND SPECIAL PURPOSE LATHES	15
	REVISION AND TEST	5
	TOTAL	80

RATIONALE:

Manufacturing, the major and the most important aspect in industries needs utmost care and attention. Knowledge about casting processes and allied areas will be of great use to the personnel involved in production.

The areas like heat treatment, powder metallurgy and knowledge in centre lathe and special purpose lathes will provide the students an opportunity to train themselves with the skills needed for the present day industrial scenario.

OBJECTIVES:

- Acquire Knowledge about types of pattern, casting, moulding.
- Explain hot working and cold working processes.
- Describe the various casting processes.
- Appreciate the safety practices used in welding.
- Explain powder metallurgy process.
- Distinguish the different heat treatment processes.
- Explain the lathe and its working parts.
- Describe the functioning of semi automatic and automatic lathes.
- Explain bulk deformation processes.
- Explain the manufacturing of plastic components.

MANUFACTURING TECHNOLOGY – I
DETAILED SYLLABUS

Contents: Theory

Unit	Name of the Topic	Hours
I	<p>CASTING PROCESSES</p> <p>Patterns – definition – pattern materials – factors for selecting pattern materials – single piece solid, split patterns – pattern allowances – core prints.</p> <p>Moulding – definition – moulding boxes, moulding sand – ingredients – silica – clay – moisture and miscellaneous materials – properties of moulding sand – sand additives – moulding sand preparation – mixing – tempering and conditioning – types of moulding – green sand – dry sand – machine moulding – Top and bottom squeezer machines – Jolting machines – sand slinger- core – CO₂ process core making – types of core – core boxes.</p> <p>Casting – definition – sand casting using green sand and dry sand – gravity die casting – pressure die casting – hot and cold chamber processes – centrifugal casting – continuous casting – chilled casting – malleable casting – melting of cast iron – cupola furnace – melting of non ferrous metals – crucible furnace melting of steel - arc furnaces – induction furnaces – instrument for measuring temperature – optical pyrometer – thermo electric pyrometer – cleaning of casting – tumbling, trimming, sand and shot blasting – defects in casting – causes and remedies – safety practices in foundry</p>	15Hrs
II	<p>JOINING PROCESSES</p> <p>Arc Welding : Definition – arc welding equipment – arc welding methods – carbon arc, metal arc, Metal Inert gas (MIG), Tungsten inert gas (TIG), Atomic hydrogen, Plasma arc, Submerged arc and Electro slag welding,</p> <p>Gas welding : Definition Gas Welding Equipment– Oxy and acetylene welding - Three types of flame– resistance welding – classification of resistance welding – butt – spot – seam – projection welding – welding related processes – oxy and acetylene cutting – arc cutting – hard facing bronze welding – soldering and brazing special welding processes – cast iron welding – thermit welding – solid slate welding, ultrasonic, diffusion and explosive welding – explosive cladding – modern welding, electron beam and laser beam welding – types of welded joints – merits and demerits of welded joints – inspection and testing of welded joints – destructive and non destructive types of tests – magnetic particle test – radiographic and ultrasonic test defects in welding – causes and remedies – safety practices in welding .</p>	15Hrs
III	<p>BULK DEFORMATION PROCESSES AND HEAT TREATMENT</p> <p>Hot working, cold working – advantages of hot working and cold working– hot working operations – rolling, forging, smith forging, drop forging, upset forging, press forging – roll forging</p>	15Hrs

	Heat treatment processes – purpose – procedures – applications of various heat treatment processes – Iron – carbon equilibrium diagram – full annealing – process annealing stress relief annealing - spherodising annealing – isothermal annealing – normalizing – hardening – tempering – quenching medium – different types and their relative merits – case hardening – pack carburizing – cyaniding – nitriding – induction hardening and flame hardening.	
IV	<p>MANUFACTURING OF PLASTIC COMPONENTS AND POWDER METALLURGY</p> <p>Plastic Components: Types of plastics-Engineering plastics – thermosets – composite - structural foam, elastomers - polymer alloys and liquid crystal polymers</p> <p>Factors Influencing The Selection Of Plastics: Mechanical properties – degradation- wear resistance -frictional properties- special properties-processing – cost</p> <p>Processing of Plastics: Extrusion-general features of single screw extrusion - twin screw extruders and types-Injection moulding types : Plunger type.- Reciprocating screw injection - details of injection mould - structural foam injection mould - sandwich moulding - gas injection moulding - injection moulding of thermosetting materials calendaring and rotational moulding. Design consideration for plastic components.</p> <p>Powder Metallurgy : Methods of manufacturing metal powders – atomization, reduction and electrolysis deposition – compacting – sintering – sizing – infiltration – mechanical properties of parts made by powder metallurgy – design rules for the power metallurgy process.</p>	15Hrs
V	<p>CENTRE LATHE AND SPECIAL PURPOSE LATHES</p> <p>Centre Lathe: Theory of lathes – specifications – simple sketches – principal parts – head stock – back geared type – all geared type – tumbler gear mechanism – quick change gear box – apron mechanism – carriage cross slide – automatic, longitudinal and cross feed mechanism – tail stock and its functions – work holding device – face plate – three jaw chuck – four jaw chuck – catch plate and carrier – types of centres – machining operations done on lathe - straight turning – step turning-taper turning-knurling-Thread cutting-Facing-Boring-chamfering—cutting speed-feed-depth of cut.</p> <p>Semi Automatic Lathes: Types of semi automatic lathes – capstan and turret lathes – difference between turret and capstan – tools and work holding devices – self opening die head – collapsible taps</p> <p>Automatic Lathes: Automatic lathe – classification of single spindle automatic lathe – principle of automatic lathes – automatic screw cutting machines – multi spindle automatic lathes</p>	15Hrs

- Text Books:**
- 1) Elements of workshop Technology Volume I & II – Hajra Chowdry & Bhattacharaya - IIth Edition - Media Promoters & Publishers Pvt. Ltd., Seewai Building `B`, 20-G, Noshir Bharucha Marg, Mumbai 400 007 – 2007.
 - 2) A Text book of workshop Technology - R.S.Khurmi & J. K. Gupta - 2nd Edition, S.Chand & Co., Ram Nagar, New Delhi – 2002.

Reference Books:

- 1) Manufacturing process – Begeman - 5th Edition -McGraw Hill, New Delhi 1981.
- 2) Workshop Technology- WAJ Chapman - Volume I, II, & III – Vima Books Pvt. Ltd., 4262/3, Ansari Road, Daryaganj, New Delhi 110 002.
- 3) Workshop Technology – Raghuwanshi - Khanna Publishers. Jain & Gupta, Production Technology, Edn. XII, Khanna Publishers, 2-B, North Market, NAI Sarak, New Delhi 110 006 - 2006
- 4) Production Technology - P. C. SHARMA - Edn. X - S.Chand & Co. Ltd., Ram Nagar, New Delhi 110 055 - 2006
- 5) Production Technology – HMT- Edn. 18 - published by Tata McGraw Hill publishing Co. Ltd., 7 West Patel nagar, New Delhi 110 008. – 2001.
- 6) Manufacturing Engineering & Technology - Kalpakjian,

22041 MANUFACTURING TECHNOLOGY - I

MODEL QUESTION PAPER-1

Time: 3 Hrs

Max Marks : 75

PART-A

Marks 15 x 1= 15

Answer any 15 Questions-All Questions carry equal marks.

1. What is pattern.
2. What are the ingredients and its composition in the green sand.
3. What are advantages of pressure die casting.
4. Name the furnace used for melting gray cast iron.
5. Name the 3 types of flame used in gas welding.
6. What type of joints can be produced in spot and seam welding processes.
7. What are the principal joints used in welding processes.
8. What is plasma?
9. What is cold working.
10. What are the advantages of press forging.
11. What are the difference between case hardening and surface hardening.
12. What is process annealing?
13. What is composite?
14. How to improve the wear resistance in plastic components.
15. What is sizing in powder metallurgy.
16. What is compacting in powder metallurgy processes.
17. Write any two principal specification of a lathe.
18. Write any two functions of a tail stock in a centre lathe.
19. Write any two difference between turret and capstan lathe.
20. What are the functions of a cam in a automatic lathe.

PART-B

Marks 5 x 12=60

Answer all the questions

21. a). i) What are difference pattern allowances provided while making patterns? **(6)**
Explain.
- ii) Explain with a neat sketch CO₂ process of core making. **(6)**
(or)
- b) i) What are the properties of good moulding sand processes? Explain. **(6)**
- ii) Explain with a neat sketch the hot chamber. **(6)**
22. a). i) Explain with a neat sketch the submerged arc welding processes. **(6)**
- ii) Explain with a neat sketch electron beam welding processes. **(6)**
(or)
- b) i) Explain with a neat sketch magnetic particle test in welded joints. Write its demerits. **(6)**

- ii) What are the safety practices used in gas welding. (6)
23. a.i) Differentiate between hot working and cold working. (6)
- ii) What is isothermal annealing? Explain. (6)
- b.i) Draw the iron carbon equilibrium diagram. Indicate the Different phase transformation. (12)
24. a). i) Differentiate between thermoplastic and thermo set plastic. (6)
- ii) What are methods of manufacturing metal powder in powder metallurgy processes. Explain with a neat sketch any one process. (6)
- b) i) Explain with a neat sketch any one injection moulding. (6)
- ii) What are the design rule in powder metallurgy processes? Explain with suitable example. (6)
25. a). i) Name the work holding devices used in a lathe. Explain with neat sketch any one such devices. (6)
- ii) Explain with a neat sketch the self opening die. (6)
- b) i) Explain with a neat sketch the all geared head stock. (6)
- ii) Explain with a neat sketch single spindle automatic lathe. (6)

**22045 MANUFACTURING TECHNOLOGY- I
MODEL QUESTION PAPER – II**

Time: 3 Hrs

Max Marks : 75

**PART – A
Marks 15 x 1 = 15**

Answer any 15 Questions – All Questions Carry Equal Marks

1. What is negative allowance?
2. Composition of the ingredients use in synthetic green moulding sand.
3. Name the additives used in dry sand mould.
4. Name any two advantages of pressure die casting.
5. List out the gas welding equipments.
6. Name the basic welding joints.
7. What destructive test in welding joints?
8. What is hard facing?
9. What is cold working?
10. What are the quenching medium used in heat treatment of steel?
11. Name any two tools used in smith forging.
12. What is tempering?
13. Write any two properties of a thermo set plaster.
14. What is composite?
15. What is sintering?
16. What is infiltration?
17. Write any two specification of a centre lathe.
18. Define feed in a lathe.
19. Name any two semi automatic lathe.
20. Classify simple spindle automatic lathe.

**PART – B
Marks 5 x 12=60
Answer all the Questions**

- 21 a. i) List the types of pattern. Explain. (6)
ii) Name any one melting furnace used for melting of aluminum. Explain with sketch. (6)
- (or)
- b.i) Write the procedure for making green sand mould. (6)
ii) Explain with a neat sketch pressure die casting in hot chamber process. (6)

22. a.i) Explain with a neat sketch the three types of flame used in gas welding process. (6)
 ii) Explain with a neat sketch the ultrasonic testing in welded joints. (6)
 (or)
- b.i) Explain with a neat sketch the Electro slag welding. (6)
 ii) Explain with a neat sketch spot welding. (6)
- 23 a.i) Differentiate between hot working and cold working. (6)
 ii) Explain the full annealing process. Write its purpose. (6)
 (or)
- b. Draw the Iron-Carbon equilibrium diagram and indicate the phase transformations. (12)
- 24 a.i) Explain with a neat sketch injection moulding machine.. (6)
 ii) Explain with a neat sketch any one method of manufacturing metal powder in powder metallurgy process. (6)
 (or)
- b.i) What are the frictional properties of plastic components? (6)
 ii) What are the design rules for the powder metallurgy components? (6)
25. a) Explain with the sketch any four operations in a lathe. (12)
 (or)
- b)i) Differentiate between capstan and turret lathes. (6)
 ii) Explain with a neat sketch single spindle automatic lathe. (6)



DIPLOMA IN AUTOMOBILE ENGINEERING

L-SCHEME

2011-2012

22142 - HEAT POWER ENGINEERING

**DIRECTORATE OF TECHNICAL EDUCATION
GOVERNMENT OF TAMILNADU**

L-SCHEME
(Implements from the Academic year 2011-2012 onwards)

Course Name : DIPLOMA IN AUTOMOBILE ENGINEERING
Course Code : 1021
Subject Code : 22142
Semester : IV
Subject Title : **HEAT POWER ENGINEERING**

TEACHING AND SCHEME OF EXAMINATIONS:

No. of Weeks per Semester : 16 Weeks

Subject	Instructions		Examination			
	Hours/Week	Hours/Semester	Marks			Duration
HEAT POWER ENGINEERING	6	96	Internal Assessment	Board Examination	Total	3 Hrs
			25	75	100	

TOPICS AND ALLOCATION OF HOURS

UNIT	TOPIC	TIME ALLOTTED (Hrs.)
I	Thermodynamics – properties of perfect gases – thermodynamic processes	18
II	Air cycles – Fuels and Combustion	18
III	Properties of steam – steam boiler – steam engine – steam condenser.	18
IV	IC engines – Performance of IC engines	18
V	Refrigeration - Airconditioning	18
	Assignment, Test and Revision	6
TOTAL		96

HEAT POWER ENGINEERING
DETAILED SYLLABUS

Contents: Theory

UNIT	Name of the topic	Hours
I	<p>Thermodynamics : Definition – fundamental units – derived units – SI units – Laws of motion – Newtons first law of motion - Newtons second law of motion - Newtons third law of motion – mass and weight – pressure – gauge and absolute pressure – temperature – absolute temperature – heat – specific heat – thermodynamic systems – properties of system – laws of thermodynamics – Zeroth law of thermodynamics – First law of thermodynamics – Second law of thermodynamics.</p>	6
	<p>Properties of perfect gases : Introduction – Laws of perfect gases – Boyle’s law – Charle’s law – general gas equation – Joule’s law – characteristic equation of gas – Avogadro’s law – Universal gas constant – Specific heats of a Gas – Specific heat at constant volume - Specific heat at constant pressure – relation between specific heats – ratio of specific heats.</p>	6
	<p>Thermodynamics processes of perfect gases : Constant volume process – constant pressure process – hyperbolic process – isothermal process – adiabatic process – polytropic process - throttling process – Derivation of heat transfer, change of internal energy, change of entropy and Work done – Simple problems.</p>	6
II	<p>Air cycles : Introduction – assumptions – classifications – efficiency of the cycle - reversible cycle – irreversible cycle – types of thermodynamic cycles – Carnot cycle – Joules cycle – Otto cycle – Diesel cycle – Dual combustion cycle – derivation – simple problems.</p>	6
	<p>Fuels: Classification – solid fuels – liquid fuels – gaseous fuels - merits and demerits – requirement of good fuel – calorific value of fuels – Higher calorific value – lower calorific value – Construction and working of bomb calorimeter and gas calorimeter.</p>	6
	<p>Combustion : Elements and compounds – atoms and molecules – atomic weight – molecular weight – combustion of solid fuels – combustion of gaseous fuels – theoretical weight of air required for complete combustion - theoretical volume of air required for complete combustion – Gravimetric analysis – Volumetric analysis – Weight of carbon in flue gases – weight of flue gases per kg of fuel burnt – Excess air supplied – weight of excess air supplied – flue gas analysis by Orsat Apparatus - simple problems.</p>	6

III	<p>Properties of Steam: Formation of steam –Temperature vs Heat – Important terms for steam – latent heat of steam - dryness fraction – wetness fraction – types of steam – dry and saturated steam, wet steam and superheated steam – advantages of super heated steam - steam tables and their uses – Total heat – volume – internal energy – entropy – simple problems using steam tables. Measurement of dryness fraction of steam – barrel calorimeter – combined separating and throttling calorimeter – working principle - problems.</p> <p>Steam Boiler: Important terms – essentials of good steam boiler – selection of a steam boiler – classification – Working principle of Locomotive boiler – Lamont boiler – BHEL boiler – merits and demerits.</p> <p>Steam engine:Classification – important parts of steam engine – working of a single cylinder double acting reciprocating steam engine – theoretical indicator diagram – actual indicator diagram.</p> <p>Steam Condenser: Advantages of a condenser in steam power plant – Requirement – Classification – Working principle of Jet condenser – types – working principle of surface condenser - types.</p>	6 6 3 3
IV	<p>IC Engines : Classification - Main components and its materials – Two stroke and four stroke cycle engine – Valve timing diagram – port timing diagram – Layout of fuel feed system petrol engine and diesel engine – scavenging – super charging - Ignition system – battery coil and magneto coil system – Cooling system – Air cooling and water cooling system – Lubrication system – Splash lubrication – pressure lubrication system.</p> <p>Performance of IC Engines : Performance of I.C engines - indicated power - brake power - friction power- efficiencies of I.C engines- indicated thermal, brake thermal, mechanical and relative efficiencies - Morse test- procedure - problems - heat balance sheet – problems.</p>	9 9
V	<p>REFRIGERATION : Refrigeration - refrigerators and heat pumps-types and applications of refrigeration - vapour compression refrigeration system - vapour absorption system – comparison – refrigerating effect - capacity of refrigerating unit - C.O.P - actual C.O.P - power required – mass of ice produced – problems - refrigerants-desirable properties - classification of refrigerants.</p> <p>AIR CONDITIONING: Air conditioning - psychometric properties - dry air - moist air - water vapour - saturated air – dry bulb temperature - wet bulb depression - dew point depression - dew point temperature – humidity - specific and relative humidity - psychometric chart – psychometric processes - sensible heating and cooling – humidification – dehumidification – classification and applications of air conditioning system - room air conditioning - central air conditioning – comparison – differences between comfort and industrial air conditioning - factors to be considered in air conditioning - loads encountered in air conditioning systems.</p>	9 9

Text Books

- 1 Applied Thermodynamics ,P.K. Nag, ,2nd Edition, TATA Mcgraw - Hill Publishing Company, New Delhi .
- 2 Thermal Engineering, R.S. Khurmi and J.K. Gupta, 18th Edition,S.Chand & Co,New Delhi

Reference Book

- 1 Thermal Engineering ,P.L Ballaney , 24th Edition ,Khanna Publishers, New Delhi.
- 2 Applied Thermodynamics, Domkundwar and C.PKothandaraman, 2nd Edition,Khanna publishers, New Delhi.
- 3 Refrigeration and Air conditioning, P. L. Ballaney, , 4th edition, Khanna Publishers, Newdelhi.
- 4 Power Plant Engineering Thermodynamics, Domkundwar and C.P Kothandaraman ., 2nd Edition , Khanna Publishers.
- 5 Power plant Engineering, G.R. Nagpal,Khanna Publishers, New Delhi.

**22142 HEAT POWER ENGINEERING
MODEL QUESTION PAPER - I**

Time: 3 Hrs

Max Marks : 75

PART A – Answer any fifteen questions. All Questions carry Equal marks. 15 x 1 = 15

- 1 State the Newtons first law of motion.
- 2 State the Zeroth law of thermodynamics.
- 3 State Avogadro's law.
- 4 State the relation between specific heats.
- 5 What is irreversible cycle?
- 6 Sketch the P-V diagram of a dual combustion cycle.
- 7 List the requirement of good fuel.
- 8 What is molecular weight?
- 9 What is latent heat of steam?
- 10 List the advantages of super heated steam.
- 11 What are the essentials of good steam boiler?
- 12 What are the requirement of steam condenser?
- 13 What is scavenging?
- 14 What is supercharging?
- 15 What is friction power?
- 16 What is indicated thermal efficiency?
- 17 What is refrigerant?
- 18 List the applications of refrigeration.
- 19 What is dew point depression?
- 20 What is humidification?

PART B: Answer all the questions

5 x 12=60

- 21 A i 0.2 kg of air at a pressure of 1.1 bar 15°C is compressed isothermally to a pressure of 5 bar. Calculate 1) Final volume 2) Heat rejected 3) Change in entropy 4) change in internal energy. Assume $R=0.292$ KJ/kg k. 12

(OR)

- B i Derive the relation between specific heats and ratio of specific heats. 6
ii Explain the expression for the adiabatic expansion process of perfect gases. 6
- 22 A i Define higher calorific value and lower calorific value. 4
ii A fuel contains 92% carbon, 4% hydrogen, 2% sulphur, oxygen 1.5%, Ash 0.5%. It is supplied with 50% excess of air. Find i) Minimum mass of air required for complete combustion of 1kg of fuel ii) Gravimetric composition of the products of combustion. 8

(OR)

- B i Explain the construction and working principle of bomb calorimeter. 6
ii Explain the construction and working principle of Orsat apparatus. 6
- 23 A i Sketch the actual indicator diagram of a steam engine 4
ii Steam at a pressure of 8.5 bar absolute and dryness fraction of 0.98 is subjected to throttling expansion of 1 bar. Find the final condition of a steam. Assume $c_{p_s} = 2.25$ KJ / Kg K. 8

(OR)

- B i Explain the working of BHEL boiler. 6
ii Explain the working of Jet condenser. 6
- 24 A i Draw the valve timing diagram and indicate the salient points. 4
ii Explain the working principle of water cooling system. 8

(OR)

- B i Write the procedure to find the heat balance sheet of IC engine. 6
ii Explain the procedure to conduct the Morse test of a multi cylinder engine. 6

- | | | | |
|------|----|--|---|
| 25 A | i | List the desirable properties of refrigerant. | 4 |
| | ii | Explain the working of vapour compression cycle refrigeration. | 8 |
| | | (OR) | |
| B | i | Write briefly about the loads encounter in air conditioning. | 4 |
| | ii | Explain the working of central air conditioning. | 8 |

22142 HEAT POWER ENGINEERING

MODEL QUESTION PAPER - II

Time: 3 Hrs

Max Marks : 75

PART A – Answer any fifteen questions. All Questions carry Equal marks. **15 x 1 = 15**

- 1 State the Newtons third law of motion.
- 2 State the First law of thermodynamics.
- 3 State Boyle's law.
- 4 State the ratio of specific heats.
- 5 Mention the important assumptions of air cycles.
- 6 Sketch the P-V diagram of a diesel cycle.
- 7 What is higher calorific value?
- 8 What is atomic weight?
- 9 What is dryness fraction?
- 10 Define entropy.
- 11 Mention the theoretical indicator diagram of steam engine.
- 12 Mention the advantages of steam condenser.
- 13 What is valve timing diagram?
- 14 What is necessity of lubrication system in IC engine?
- 15 What is indicated power?
- 16 What is relative thermal efficiency?
- 17 What is refrigeration?
- 18 What is refrigerating effect?
- 19 What is humidity?
- 20 What is dehumidification?

PART B: Answer all the questions

5 x 12=60

- 21 A i Explain the expression to find the heat transfer and work done for the constant volume expansion process of perfect gases. 12
- (OR)**
- B i Derive the characteristic equation of gas. 6
- ii Derive the relation between specific heats. 6
- 22 A i Mention the requirement of good fuel. 4
- ii Explain the principle of orsat apparatus. 8
- (OR)**
- B i Explain the construction and working principle of gas calorimeter. 6
- ii Explain the construction and working principle of Bomb calorimeter. 6
- 23 A i Explain the working of single cylinder double acting steam engine with indicator diagram. 12
- (OR)**
- B i Explain the working of lamont boiler. 6
- ii Explain the working of surface condenser. 6
- 24 A i Draw the port timing diagram and indicate the salient points. 4
- ii Explain the working principle of lubrication system. 8
- (OR)**
- B i Describe about supercharging. 4
- ii Explain the battery coil ignition system. 8
- 25 A i A refrigerating plant is required to produce 10 tonnes of ice per day at -4°C from water at 19°C . The compressor works between the temperature limits of 25°C and -8°C . Calculate the power required to drive the compressor, if the system works on reversed carnot cycle. Take latent heat of ice = 336 kJ/kg and sp.heat of ice 2.1kJ/kgtg K. 12
- (OR)**
- B i Explain the different psychometric process. 12



DIPLOMA IN AUTOMOBILE ENGINEERING

L-SCHEME

2011-2012

22143 - INDUSTRIAL AUTOMATION

DIRECTORATE OF TECHNICAL EDUCATION

GOVERNMENT OF TAMILNADU

L-SCHEME
(Implements from the Academic year 2011-2012 onwards)

Course Name : DIPLOMA IN AUTOMOBILE ENGINEERING
Course Code : 1021
Subject Code : 22143
Semester : IV
Subject Title : **INDUSTRIAL AUTOMATION**

TEACHING AND SCHEME OF EXAMINATIONS:

No. of Weeks per Semester : 16 Weeks

Subject	Instructions		Examination			Duration
	Hours/ Week	Hours/ Semester	Marks			
INDUSTRIAL AUTOMATION	5	80	Internal Assessment	Board Examination	Total	3 Hrs
			25	75	100	

TOPICS AND ALLOCATION OF MARKS

UNIT	TOPIC	TIME ALLOTTED (Hrs.)
I	FLUID POWER – PUMP AND MOTOR	15
II	CONTROL VALVES AND CIRCUITS	15
III	SELECTION OF DEVICES	15
IV	PNEUMATIC SYSTEM	15
V	PROGRAMMABLE LOGIC CONTROLLER	15
	Test & Revision	5
TOTAL		80

RATIONALE

Impart knowledge about the automation process in the automobile industries. To acquire knowledge about the hydraulic and pneumatic systems and its functions of the components. Understand the control methods of automation.

OBJECTIVES

- To learn the types of chassis and axles.
- To study about the steering system and its methods.
- To understand the suspension systems and its components.
- To learn the functions of universal joint and propeller shafts.
- To study working principle of differential unit.
- To learn about the types of brakes and tyres.
- To know the function of clutch and gear box and its types

22143 - INDUSTRIAL AUTOMATION

DETAILED SYLLABUS

Contents: Theory

UNIT	Name of the topic	Hours
I	<p>Fluid power – Pump and Motor Introduction to Fluid Power System and its basic components – Basic law – applications of fluid power – Advantages and drawbacks of fluid power. Classification – Positive displacement Pumps - Gear pump, Lobe pump, Vane pump, Piston pump – Pump performance – Pump noise – Pump selection. Cylinder mountings and mechanical linkages – Cylinder force, velocity and Power – Cylinder loads due to moving of weights – Cylinder loading through mechanical linkages – Hydraulic cylinder cushions and shock absorbers. Analysis of torque capacity – Gear motor – Vane motor – Piston motor – Hydraulic motor theoretical torque, power and flow rate – Hydraulic motor performance.</p>	
II	<p>Control Valves and Circuits Pressure Control Valves (PCV): Simple pressure relief valve, Compound pressure relief valve, Pressure reducing valve, Unloading valve, Sequence valve, Counter balance valve. Flow Control Valves (FCV): Orifice as flow control valve, Needle valve, Pressure compensated and Nonpressure compensated valve. Direction Control Valves (DCV): Check valve, Pilot operated check valve, three-way valve, four-way valve: Manual/Mechanical/Solenoid operated valves. Servo valves: Definition – Mechanical-hydraulic servo valve – Electro-hydraulic servo valves. Accumulators: Reservoirs and accumulators – Types of accumulators – Charging and discharging of accumulators – Accumulator circuits. Deceleration circuit – Intensifier circuit – Regenerative circuit – Synchronizing circuit – Automatic cylinder reciprocating circuit – Sequencing circuit. Safety Circuits: Two-hand safety control circuit – Fail-safe control circuit by using emergency cut-off valve.</p>	
III	<p>Selection of devices Selection of Hydraulic Cylinder: Speed of a hydraulic cylinder – Cylinder thrust – Acceleration and deceleration of cylinder loads – Local deceleration – Cylinder cushioning – Cylinder preferred sizes – Piston rod buckling. Selection of Hydraulic Motor: Hydro-static drives – Hydro-static drive characteristics – Braking of hydrostatic drives – Matching motor to load. Selection of Control Valves: Relief valves – Flow control valves – Direction control valves. Selection of Other Devices: Seals and its classification – Filters and its types – Filter location. Selection of filters – Selection of conduits - tubing and hoses – Selection of pump – Pressure losses – Reservoir and its design – Sizing of accumulator.</p>	
IV	<p>Pneumatic system Comparison of pneumatic system with hydraulic system – Basic pneumatic system: Air filter, Pressure regulator, Lubricator and Muffler – Pneumatic valves: Direction control valve, Flow control valve, Shuttle valve, Two-pressure valve, Quick exhaust valve and Time delay valve.</p>	

	<p>Cylinders – Air-motors and its types – Basic pneumatic circuits: Simple circuit, Material handling circuit.</p> <p>Hydro-pneumatics: Air-oil reservoir – Air-oil cylinder – Air-oil intensifier – Comparison of hydraulic, pneumatic and hydro-pneumatic systems. Advantages – Pneumatic sensors – Position sensors and its types – Pressure sensor – Switching elements. Operation of single-acting cylinder – Operation of double-acting cylinder – Air-pilot control of double-acting cylinder – Cylinder cycle timing system – Two-step speed control system – Two-handed safety control system – Control of air motor – Deceleration air cushion of cylinder.- circuit – Control of pneumatic cylinder using flip-flop.</p>	
V	<p>Programmable Logic Controller</p> <p>Introduction to PLC – evolution – advantages – criteria for selection of suitable PLC – Block diagram of PLC – Programming devices – programming methods – STL and CSF, FBD and Ladder methods – simple instructions – programming NC and NO contacts – timer instructions – on-delay and off-delay timer – converting simple relay ladder diagram into PLC relay ladder diagram – PID and PWM functions. Simple PLC implementations for automatic star-delta starter and 4 floor lift system. Introduction and brief history of SCADA – hardware and software</p>	

Text Books

- 1 Pneumatic Systems Principles and Maintenance, S.R. Majumdar – Tata McGraw Hill Pub co
- 2 Introduction to Programmable Logic Controllers, Gary Dunning - Thomson Delmar Learning Second Edition Second reprint 2003

Reference Book

- 1 Fluid Power by Harry L. Stewart – Audel Series
- 2 Hydraulics & Pneumatics Power for production Harry L Stewart – Industrial Press Inc, New York
- 3 Pneumatic circuit by Harry L. Stewart – Audel Series
- 4 Fundamentals of pneumatic control Engg – Text book By Festo
- 5 Introduction to Pneumatics – Test Book by Festo

22143 - INDUSTRIAL AUTOMATION

MODEL QUESTION PAPER - I

Time: 3 Hrs

Max Marks : 75

PART A – Answer any fifteen questions. All Questions carry Equal marks. **15 x 1 = 15**

- 1 List the advantages of fluid power.
- 2 What is cylinder force?
- 3 What is use of cylinder cushions?
- 4 List the applications of fluid power.
- 5 What is the use of pressure relief valve?
- 6 Mention the types of filters.
- 7 What is accumulator?
- 8 Classify the seals.
- 9 What is cylinder thrust?
- 10 Mention the characteristic of hydro static drive.
- 11 Mention the location of filter.
- 12 What is a pressure loss?
- 13 Mention the types of air motors.
- 14 What is shuttle valve?
- 15 Mention the advantages of pneumatic system.
- 16 What is a pneumatic sensor?
- 17 List the advantages of PLC.
- 18 What is ON delay and Off delay timer?
- 19 List the criteria for selection of PLC.
- 20 Mention the programming methods of PLC.

PART B: Answer all questions.

5 x 12=60

- | | | |
|-------------|--|----|
| 21 A | Explain the working of gear pump and lobe pump with neat sketch. | 12 |
| (OR) | | |
| B | Explain the working of piston motor and vane motor with neat sketch. | 12 |
| 22 A | i Draw and explain the circuit of a counter balance valve. | 4 |
| | ii Draw and explain the automatic cylinder reciprocating circuit. | 8 |
| (OR) | | |
| B | i Write briefly about the electro- hydraulic servomotor. | 4 |
| | ii Draw and explain the Fail safe control circuit using emergency cut-off valve. | 8 |
| 23 A | i Explain about the selection hydraulic cylinder. | 6 |
| | ii Explain about the selection of flow control valve. | 6 |
| (OR) | | |
| B | i Explain about the selection tubing and hoses. | 7 |
| | ii Explain about the reservoir and its design. | 5 |
| 24 A | i Explain the working of time delay valve. | 4 |
| | ii Explain the material handling circuit. | 8 |
| (OR) | | |
| B | i Write briefly about the pressure sensor. | 4 |
| | ii Explain the working of air pilot control of double acting cylinder. | 8 |
| 25 A | i Write briefly about the PID and PMW functions. | 6 |
| | ii Write the program for 4 floor lift system. | 6 |
| (OR) | | |
| B | i Explain the history of SCADA. | 4 |
| | ii Explain the programming methods of PLC. | 8 |

22143 - INDUSTRIAL AUTOMATION

MODEL QUESTION PAPER - II

Time: 3 Hrs

Max Marks : 75

PART A – Answer any fifteen questions. All Questions carry Equal marks. **15 x 1 = 15**

- 1 Why the pump noise occur?
- 2 What is shock absorbers?
- 3 Mention the drawbacks of fluid power.
- 4 What is flow rate?
- 5 What is the use of DCV?
- 6 What is servo valve?
- 7 Mention the types of accumulator.
- 8 Mention the types of filters used.
- 9 What is local deceleration?
- 10 Mention any two standard size of cylinder.
- 11 What is piston rod buckling?
- 12 What is pressure losses?
- 13 What is purpose of muffler?
- 14 What is the necessity of air filter in pneumatic circuit?
- 15 Mention the advantages of hydro-pneumatic systems.
- 16 What is the use of shuttle valve?
- 17 Mention the advantages of PLC.
- 18 Mention the methods of programming in PLC.
- 19 What is ladder diagram?
- 20 What is SCADA?

PART B: Answer all questions.

5 x 12=60

- | | | | |
|-------------|----|--|----|
| 21 A | i | Explain the working of hydraulic cylinder cushions and shock absorbers. | 12 |
| (OR) | | | |
| B | i | Explain the working of positive displacement pumps. | 12 |
| 22 A | i | Draw and explain the regenerative circuit. | 4 |
| | ii | Explain about charging and discharging of accumulator. | 8 |
| (OR) | | | |
| B | I | Write briefly about the pressure compensated and non pressure compensated valve. | 4 |
| | ii | Draw and explain the two hand safety control circuit. | 8 |
| 23 A | i | Explain about acceleration and deceleration of cylinder loads. | 6 |
| | ii | Explain about the reservoir and its design. | 6 |
| (OR) | | | |
| B | i | Explain about the selection direction control valve. | 6 |
| | ii | Explain about the selection of pumps. | 6 |
| 24 A | i | Explain the working of quick exhaust valve. | 4 |
| | ii | Explain the control of pneumatic cylinder using flip-flop. | 8 |
| (OR) | | | |
| B | i | Write briefly about the position sensor. | 4 |
| | ii | Explain the working of two step speed control system . | 8 |
| 25 A | i | Explain how simple ladder diagram is converted into PLC ladder diagram with example. | 12 |
| (OR) | | | |
| B | i | Explain the criteria to select suitable PLC. | 4 |
| | ii | Explain the any two programming methods of PLC. | 8 |



DIPLOMA IN AUTOMOBILE ENGINEERING

L-SCHEME

2011-2012

**22144 - COMPUTER AIDED MACHINE DRAWING
PRACTICAL**

**DIRECTORATE OF TECHNICAL EDUCATION
GOVERNMENT OF TAMILNADU**

L-SCHEME
(Implements from the Academic year 2011-2012 onwards)

Course Name : DIPLOMA IN AUTOMOBILE ENGINEERING
Course Code : 1021
Subject Code : 22044
Semester : IV
Subject Title : **COMPUTER AIDED MACHINE DRAWING PRACTICAL**

TEACHING AND SCHEME OF EXAMINATIONS:

No. of Weeks per Semester : 16 Weeks

Subject	Instructions		Examination			Duration
	Hours/Week	Hours/Semester	Marks			
Computer Aided Machine Drawing Practical	5	80	Internal Assessment	Board Examination	Total	3 Hrs
			25	75	100	

Topics and Allocation of Hours:

Unit No	Topics	Hours
I	INTRODUCTION TO CAD SOFTWARE	3
II	DRAWING AIDS AND EDITING COMMANDS	6
III	BASIC DIMENSIONING, HATCHING, BLOCKS AND VIEWS	6
IV	ISOMETRIC DRAWING, PRINTING AND PLOTTING	6
V	<u>CAD DRAWING PRACTICE</u> DETAILED DRAWINGS OF FOLLOWING MACHINE PARTS ARE GIVEN TO STUDENTS TO ASSEMBLE AND DRAW THE SECTIONAL OR PLAIN ELEVATIONS / PLANS / AND SIDE VIEWS WITH DIMENSIONING AND BILL OF MATERIALS USING CAD SOFTWARE – 12 EXERCISES: SLEEVE & COTTER JOINT, SPIGOT & COTTER JOINT, KNUCKLE JOINT, STUFFING BOX, SCREW JACK, FOOT STEP BEARING, UNIVERSAL COUPLING, PLUMMER BLOCK, SIMPLE ECCENTRIC, MACHINE VICE, CONNECTING ROD, PROTECTED TYPE FLANGED COUPLING.	72
	REVISION AND TEST	3
	TOTAL	96

RATIONALE:

The contemporary progressing world is fast with the latest production systems. The advanced manufacturing of products is developed instantly using CAD Software. Even a small scale industry is now using a CAD software as it has become the heart of the Design department. So CAD has now become inevitable in industries.

Accuracy and Precision are the two important things that decide the quality of a product to survive its competitors in the market. Using CAD software design, the uniform accuracy, multiples of copies and storing in a small space for long time are assured.

The CAD software considerably improves the creativity and flexibility of a designer. The syllabus here enables a candidate to draw an industrial drawing within the optimum reach of a diploma cadre.

OBJECTIVES:

- Appreciate the need of sectional view and types of sections.
- Draw sectional views using different types of sections.
- Explain the use of threaded fasteners and the types of threads.
- Compare hole basis system with shaft basis system.
- Select different types of fits and tolerance for various types of mating parts.
- Practice on CAD commands in making 2D Drawings.
- Draw assembled drawings of different types of joints and couplings using CAD.
- Draw assembled drawings of various types of machine elements using CAD.

COMPUTER AIDED MACHINE DRAWING PRACTICAL

DETAILED SYLLABUS

Contents: Theory

Unit	Name of the Topic	Hours
I	INTRODUCTION TO CAD SOFTWARE Introduction – History of CAD – Applications – Advantages over manual drafting – Hardware requirements – Software requirements – Windows desktop – CAD screen interface – menus – Tool bars – How to start CAD – How to execute command – types of co-ordinate systems – Absolute – Relative – Polar.	3Hrs
II	DRAWING AIDS AND EDITING COMMANDS Creating objects (2D) – Using draw commands – Line, Arc, Circle, Ellipse, Donut, Polygon, Point, Pline, Sketch, Trace – Creating 2D Solid. Creating text – Dtext, Mtext, Text styles – Mline, spline – Drawing with precision – Osnap options – drafting settings –limits – Units – drawing aids – Fill, Snap, Grid, Ortho lines – Function keys - Editing and modify commands – Object selection methods – Erasing object – Oops - Cancelling and undoing a command – Copy – Move – Array – Offset – Scale – Rotate – Mirror – Break – Trim – Extend – Explode. Divide – Measure – stretch – Lengthen – Changing properties – Color – line types –LT scale – Matching properties – Editing with grips – Pedit – Ddedit – Mledit.	6Hrs
III	BASIC DIMENSIONING, HATCHING, BLOCKS AND VIEWS Basic dimensioning – Editing dimensions – Dimension styles – Dimension system variables. Machine drawing with CAD. Creation of blocks – Wblock – inserting a block – Block attributes – Hatching –Pattern types – Boundary hatch – working with layers - Controlling the drawing display – Blipmode – View group commands – Zoom, redraw, regen, regenauto, pan, viewres – Real time zoom. Inquiry groups – calculating area – Distance – Time – Status of drawing – Using calculator.	6Hrs
IV	ISOMETRIC DRAWING, PRINTING AND PLOTTING Isometric drawing – Isometric projection – drawing isocircles – Dimensioning isometric objects. File commands – File Import and export – plotting drawing – external references – 3D fundamentals – 2D to 3D Conversion 3D Drawing : 3D Primitives-Extrude – Revolve-Slice-Section, Surface 3D Mesh-3D - Surface-3D Operation-Solid Editing	6Hrs

V	CAD DRAWING PRACTICE	72Hrs
	Detailed drawings of following machine parts are given to students to assemble and draw the sectional or plain elevations / plans / and side views with dimensioning and bill of materials using CAD Software	
	1.Sleeve & Cotter joint 2.Spigot & Cotter joint 3.Knuckle joint 4.Stuffing Box 5.Screw Jack 6.Foot step bearing 7.Universal Coupling 8.Plummer Block 9.Simple Eccentric 10.Machine Vice 11.Connecting Rod 12.Protected type flanged coupling 13.Practice on Isometric Drawing	3D Drawing <ol style="list-style-type: none"> 1. Geneva Wheel 2. Bearing Block 3. Bushed bearing(Assembly) 4. Gib and Cotter(Assembly) 5. Screw Jack(Assembly) <p>Note: Take the orthographic view and sectional view from the above assembled 3D drawing.</p>

Reference Books:

- 1) Inside AutoCAD - D. Raker and H. Rice - BPB Publications, NewDelhi
- 2) Engineering Drawing and Graphics + AutoCAD – K.Venugopal, - New Age International Publications
- 3) CAD/CAM/CIM - P. Radhakrishnan, S. Subramaniyan and V.Raju - New Age International Publications.
- 4) AutoCAD 2002 with Applications - Sham Tickoo - Tata Mcgraw Hill.
- 5) Computer Graphics, Prentice – Donald Hearn, M. Pauline Baker - Hall of India Pvt. Limited, NewDelhi.

LIST OF EQUIPMENT

1. Personal computer (With latest processor to suit Auto CAD) – 30 No's
2. MS Windows OS – 30 No's
3. AutoCAD software (release 2000 or above) – 30 Users

Board of Examination

Part A (I to IV units)

One Mark question contain - 1 x 10 = 10 Marks

Part B – V Unit

1. Assembled view of a given drawing- 45 Marks
(2 or 3 views)

2. 3D drawing using 3D commands – 15 Marks

Viva voce - 5 Mark

Total 75 Marks

Note to the examiner:

Part A

- Answer any 10 questions out of 15 questions.
- Fifteen questions should cover the complete syllabus (UNIT I to IV)

Part-B

- Answer should be evaluated from the print out for the Part-B questions.(1 & 2).
- Examiner should set the question paper to cover the complete syllabus of Unit-V. (Unit-V – 13 Drawings for Part-B 1st question).
- Examiner has to ask the student to answer any one question from the lot of 13 drawings.
- Examiner has to set the no. of questions minimum 13 even one batch of students contains less than 13.
- 3D Drawing creations the examiner should set the question paper to cover the complete syllabus of Unit-V. (Unit-V – 5 3D Drawings for Part-B 2nd question).



DIPLOMA IN AUTOMOBILE ENGINEERING

L-SCHEME

2011-2012

**22045 - MANUFACTURING TECHNOLOGY – I
PRACTICAL**

**DIRECTORATE OF TECHNICAL EDUCATION
GOVERNMENT OF TAMILNADU**

L-SCHEME
(Implements from the Academic year 2011-2012 onwards)

Course Name : DIPLOMA IN AUTOMOBILE ENGINEERING
Course Code : 1021
Subject Code : 22045
Semester : IV
Subject Title : **MANUFACTURING TECHNOLOGY – I PRACTICAL**

TEACHING AND SCHEME OF EXAMINATIONS:

No. of Weeks per Semester : 16 Weeks

Subject	Instructions		Examination			Duration
	Hours/Week	Hours/Semester	Marks			
Manufacturing Technology – I Practical	6	96	Internal Assessment	Board Examination	Total	3 Hrs
			25	75	100	

OBJECTIVES:

- Identify the parts of a center lathe
- Identify the work holding devices
- Set the tools for various operations
- Operate the lathe and Machine a component using lathe
- Identify the tools used in foundry.
- Identify the tools and equipments used in welding
- Prepare sand moulds for different patterns.
- Perform welding operation to make different types of joints.
- Identify the different welding defects.
- Appreciate the safety practices used in welding.

Note: All dimensions in mm

Manufacture and estimate the cost of the job for following exercises by assuming the suitable raw material for the final size of the components.

Note to the faculty :-Last job of the raw material(MS Rod $\text{Ø}32 \times 77\text{mm}$ and MS Rod $\text{Ø}25 \times 77\text{mm}$) to be retain in student wise or batch wise .This may be verifiable at the time of Board Practical Examination by the external examiner

All linear dimensions in $\pm 0.5\text{mm}$ tolerance.

All cylindrical dimensions in $\pm 0.2\text{mm}$ tolerance.

1. Lathe

1. Introduction of safety in operating machines.
2. Introduction to lathe and its parts.
3. Introduction to work holding devices and tool holding devices.
4. Types of tools used in lathe work.
5. Types of measuring instruments and their uses.
6. Setting of work and tools.
7. Operation of lathe.
8. Practice on a lathe.

Exercises :

1. Plain turning
2. Step turning
3. Taper turning
4. Knurling
5. Thread cutting
6. Bushing

2. Foundry

1. Introduction of tools and equipments
2. Types of patterns
3. Types of sand
4. Preparation of sand moulds
5. Furnaces – crucible furnace and tilting furnace
6. Melting of non ferrous metal
7. Core sands, preparation of cores

Exercises :

Preparation of sand mould :

1. Solid pattern
 - a. Stepped pulley
 - b. Bearing top
 - c. Gear Wheel
 - d. T-pipe
2. Split pattern
 - a. Bent Pipe
 - b. Dumbles
3. Loose Piece Pattern – Dowtail
4. Cylindrical core making
5. Melting and casting – (not for Examination, only for class exercises)

3. Welding

1. Introduction of Safety in welding shop
2. Introduction to hand tools and equipments
3. Arc and gas welding equipments
4. Types of joints

Exercises :

1. Arc welding
 - Lap joint (Material : 25 mm x 6mm MS flat)
 - Butt joint (Material : 25mm x 6mm MS flat)
 - T- joint (Material : 25mm x 6mm MS flat)
 - Corner joint (Material : 25mm x 6mm MS flat)
2. Gas Welding
 - Lap joint (Material : 25mm x 3mm Ms flat)
 - Butt joint (Material : 25mm x 3mm Ms flat)
 - T- joint (Material : 25mm x 3mm Ms flat)
 - Corner joint (Material : 25mm x 3mm Ms flat)
3. Gas cutting : Profile cutting
4. Spot welding – Lap joint (18/20swg)
5. Demonstration of Soldering and brazing

Lathe Exercises:

Exercise No:1 –Plain turning .

Raw Material: MS Rod $\text{Ø}32 \times 77 \text{mm}$

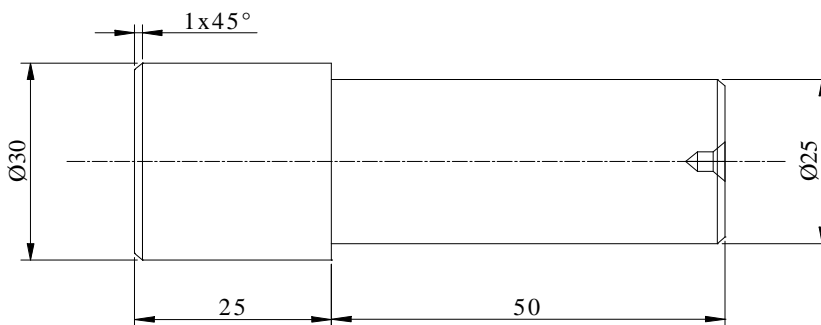

Exercise No:2-Step turning

Raw Material: Exercise No:1

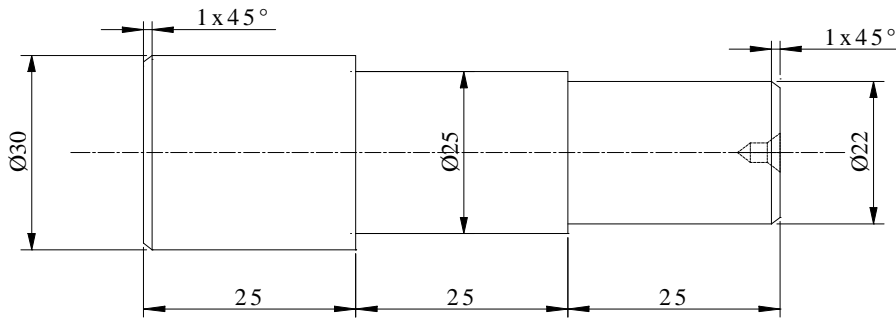

Exercise No:3-Step and taper turning

Raw Material: Exercise No:2

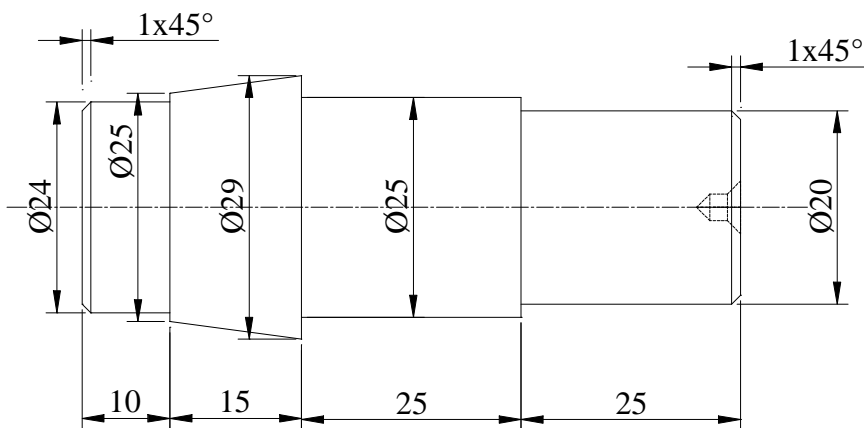

Exercise No: 4-Step and taper turning

Raw Material: Exercise No: 3

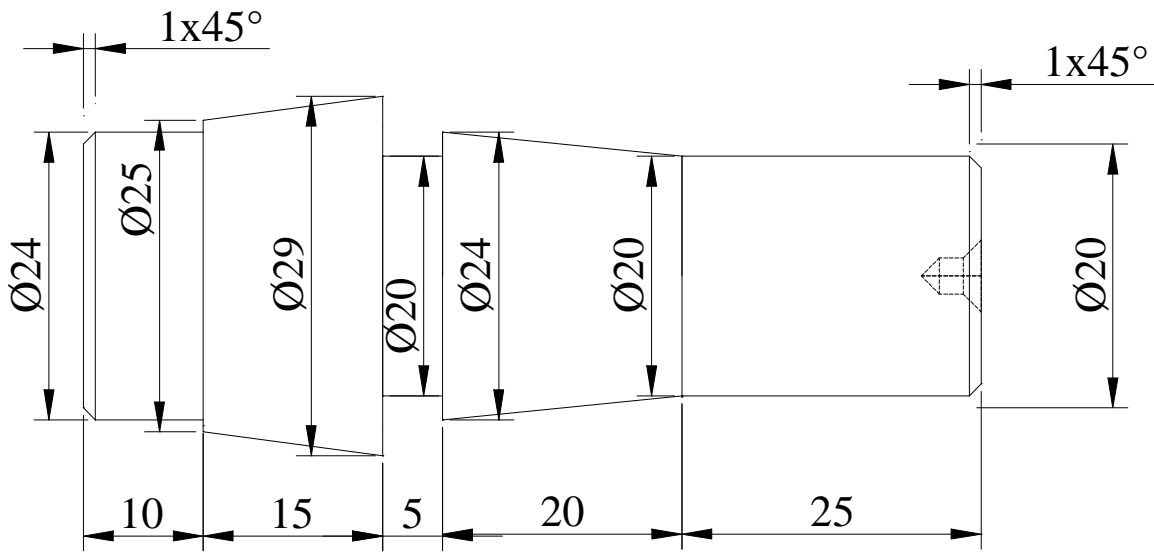

Exercise No: 5 Knurling and step turning

Raw Material: Exercise No:4

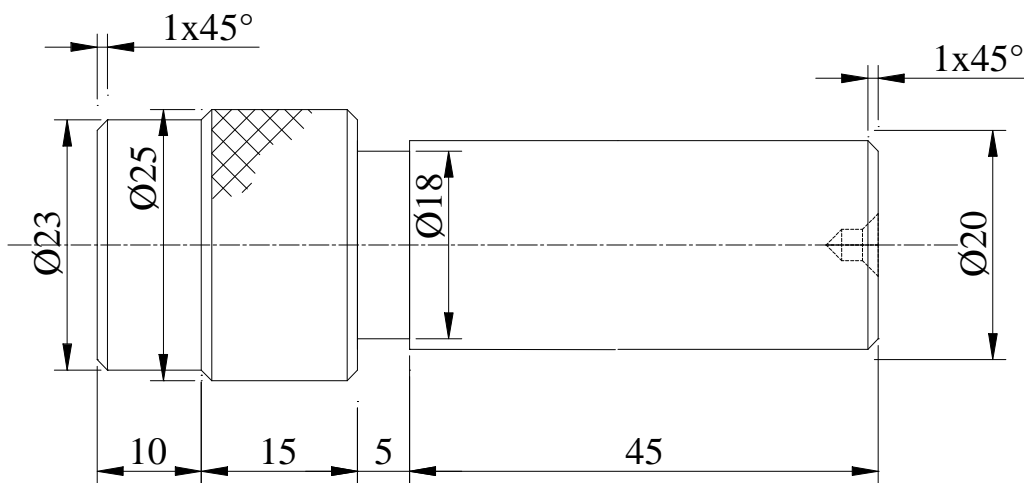

Exercise No:6 - BSW Thread cutting

Raw Material: Exercise No:5

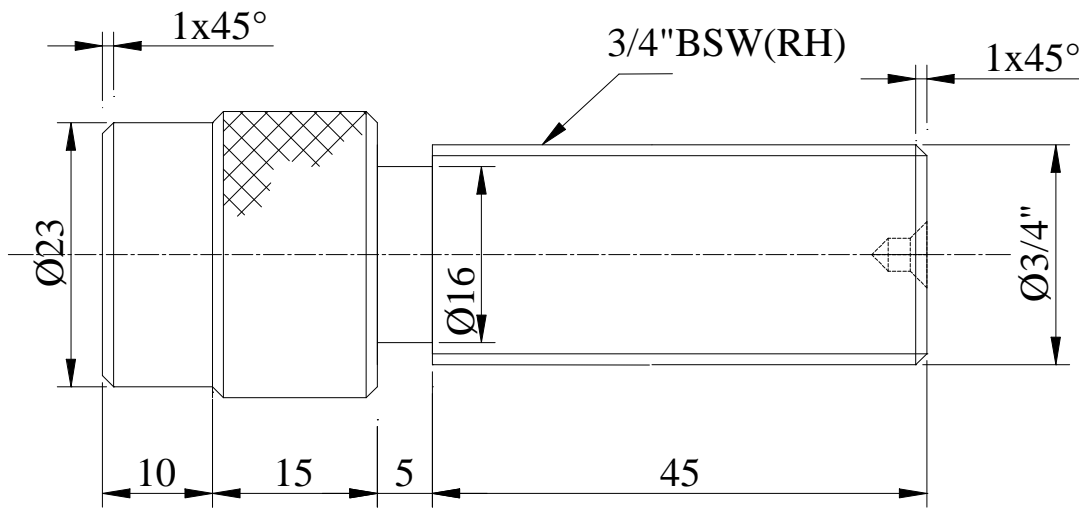

Exercise No:7 – Metric thread cutting

Raw Material: Exercise No:6

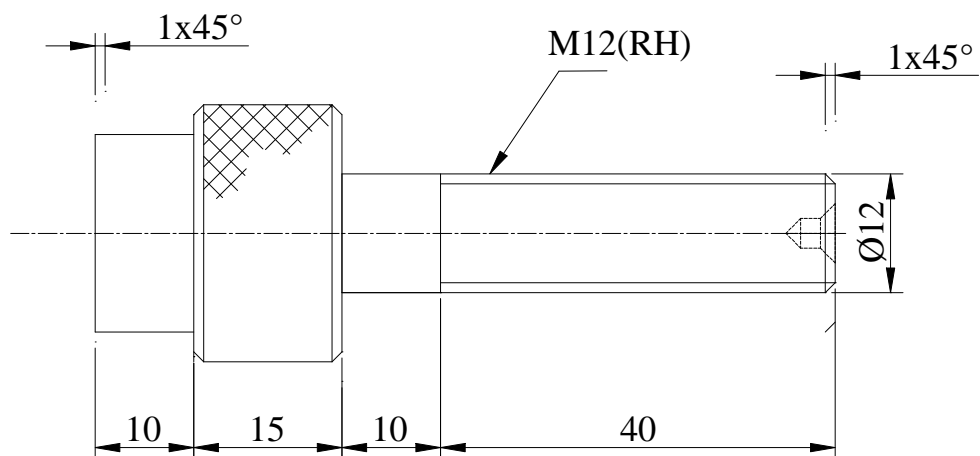

Exercise No:8- Metric thread cutting

Raw Material: Exercise No:7

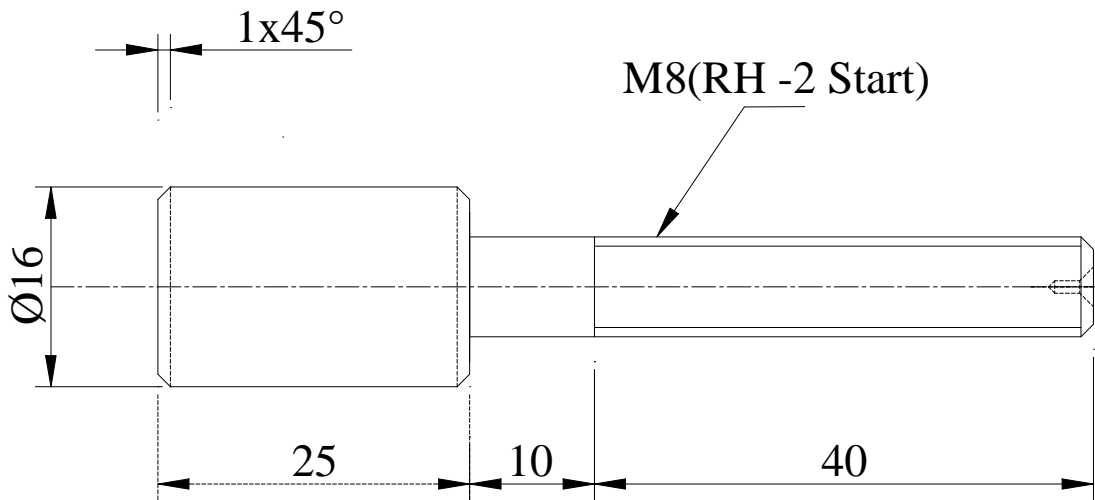

Exercise No: 9-Shaft and bush mating

Raw Material: MS Rod $\text{Ø}25 \times 77 \text{mm}$ and $\text{Ø}32 \times 30 \text{mm}$

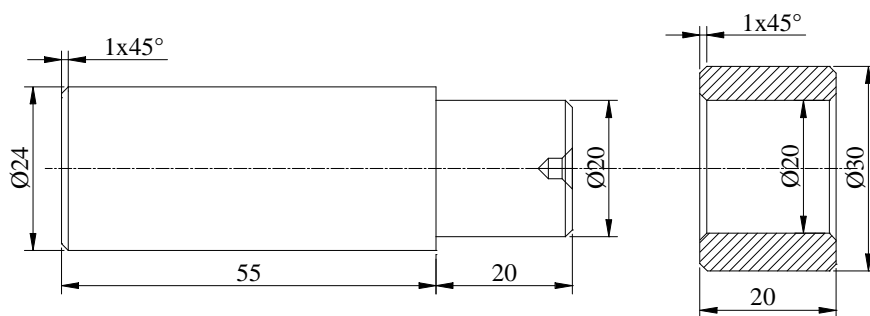

Exercise No: 10- Thread cutting

Raw Material: Exercise No:9

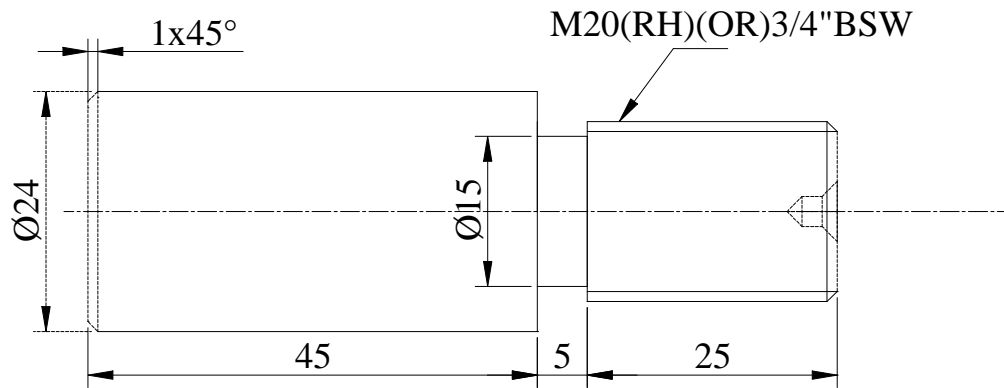

Exercise No:11- Thread cutting

Raw Material: Exercise No:10

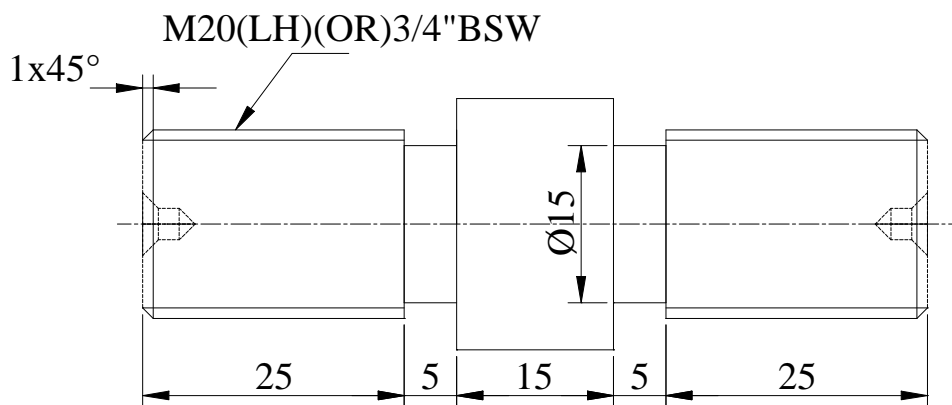

Exercise No:12-Eccentric Turning

Raw Material: Exercise No:11

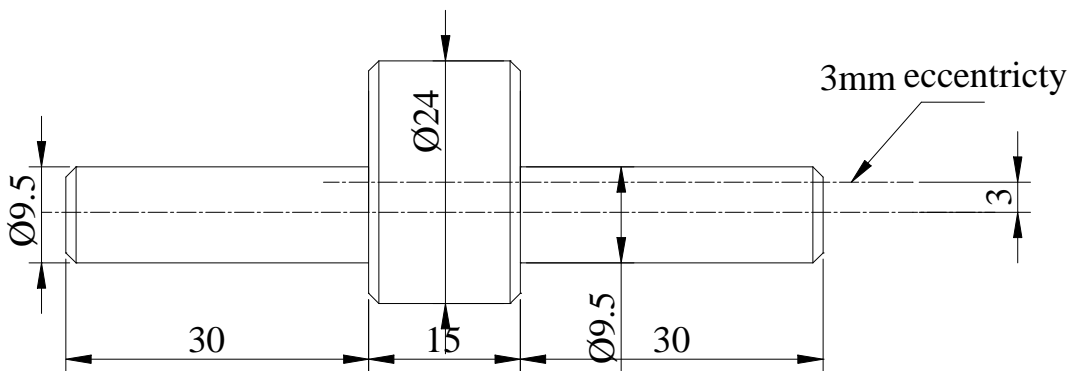

BOARD EXAMINATION

Lathe : 45 marks (2hours)

Foundry (or) Welding : 25 marks (1 hour) (By lot, Equal distribution in a session)

Viva-voce : 05 marks

Total : 75 marks

Each Batch/Session the allocation of exercises (Lathe):

75% of the questions in the combination of step, knurling / taper and thread cutting.

Remaining 25% of the questions to be in the combination of taper, step, knurling and under cut.

LIST OF EQUIPMENT

Turning:

1. Center Lathe 4 ½ ' Bed length	–	15 No's
2. 4 Jaw / 3 Jaw Chucks	–	required Numbers
3. Chuck key (10 mm x 10 mm size)	–	15 No's
4. Box spanner	–	15 No's
5. Cutting Tool H.S.S ¼ " X ¼ " X 4 " long	–	15 No's
6. Pitch gauge	–	5 Nos
7. Vernier Caliper (0-25 and 25-50)	–	5 nos each
8. Micrometer, Inside and Outside(0-25 and 25-50)	-	5 each
9. Vernier Height Gauge(300mm)	-	1 no
10. Snap gauge	–	1 set
11. Gear tooth Vernier	-	1 No
12. Parallel Block	-	2 Nos
13. Steel Rule (0-150)	–	15 Nos.
14. Outside and Inside Calipers	-	15 Nos. each
15. Thread gauge	–	5 Nos.
16. Bevel Protractor	–	1 No
17. Jenny Caliper	–	5 Nos.
18. Dial Gauge with Magnetic Stand	–	5 Nos.
19. Marking Gauge	–	10 Nos.
20. Safety Glass	–	15 Nos.

Welding:

1. Arc welding booth	–	2 No's with oil /air cooled welding transformer with accessories
2. Gas welding unit (Oxygen and acetylene cylinder)	–	1 Set
3. Flux	–	500 grams
4. Electrode 10 SWG	–	200 No's
5. Face shield	–	3 No's
6. Gas welding goggles	–	2 No's
7. Leather Glows 18"	–	4 Set
8. Flux chipping hammer	–	4 No's
9. Spot welding machine	-	1 No

Foundry:

1. Crucible furnace	-	1 No
2. Tilting furnace	-	1 No
3. Shovel	-	20 Nos
4. Rammer set	-	30 Nos
5. Slick	-	30 Nos
6. Strike-off bar	-	30 Nos
7. Riddle	-	15 Nos
8. Trowl	-	30 Nos
9. Lifter	-	30 Nos

10. Sprue pin	-	60 Nos
11. Brush	-	20 Nos
12. Vent rod	-	30 Nos
13. Draw spike	-	30 Nos
14. Gate cutter	-	30 Nos
15. Cope box	-	30 Nos
16. Drag box	-	30 Nos
17. Core box	-	10 Nos
18. Runner & riser	-	60 Nos
19. Moulding board	-	30 Nos
20. Patterns	-	15 Nos each



DIPLOMA IN AUTOMOBILE ENGINEERING

L-SCHEME

2011-2012

22146 - HEAT POWER ENGINEERING PRACTICAL

DIRECTORATE OF TECHNICAL EDUCATION

GOVERNMENT OF TAMILNADU

L-SCHEME
(Implements from the Academic year 2011-2012 onwards)

Course Name : DIPLOMA IN AUTOMOBILE ENGINEERING
Course Code : 1021
Subject Code : 22146
Semester : IV
Subject Title : **HEAT POWER ENGINEERING PRACTICAL**

TEACHING AND SCHEME OF EXAMINATIONS:

No. of Weeks per Semester : 16 Weeks

Subject	Instructions		Examination			Duration
	Hours/ Week	Hours/ Semester	Marks			
HEAT POWER ENGINEERING PRACTICAL	4	64	Internal Assessment	Board Examination	Total	3 Hrs
			25	75	100	

Note: All the experiments should be conducted and Examination will be conducted one experiment from each Part.

PART A

24 Hrs.

1. Draw Port timing diagram / Valve timing diagram
2. Find Flash and Fire point – open cup and closed cup
3. Find Viscosity of lubricating oil – Say bolt viscometer
4. Find Viscosity of lubricating oil –Red wood viscometer
5. Find Calorific Value of fuels – Solid fuels
6. Find Calorific Value of fuels – Liquid fuels

PART B

40 Hrs.

1. Conduct the performance test of Petrol engine and draw the performance curve.
2. Conduct the performance test of Diesel engine and draw the performance curve.
3. Morse test on multi cylinder Petrol or Diesel engine.
4. Draw Heat balance sheet of a Petrol / Diesel Engine.
5. Find the percentage of NO, NO₂, NH₃, N₂O, HNCO in the exhaust gas using exhaust gas analyzer.
6. Find the soot content in the samples of exhaust of diesel engines using smoke meter.

BOARD EXAMINATION - DETAILED ALLOCATION

Note: Question paper should have two questions one from each part.

PART A

Reading / Observation	- 15
Result	- 5

PART B

Observation / Tabular column	- 20
Formulae / Calculation	- 20
Graph / Result	- 10

Viva Voice	- 5
-------------------	-----

TOTAL	75
--------------	-----------

Resources required : Minimum one number is required for 60 intake. Based on the increase in intake the facility should be improved.

1. Model for Port timing diagram / Valve timing diagram
2. Open cup apparatus and Closed cup apparatus
3. Say bolt viscometer
4. Red wood viscometer
5. Bomb Calorimeter
6. Petrol engine test rig to conduct load test
7. Diesel engine test rig to conduct load test
8. Multi cylinder Petrol or Diesel engine.
9. Petrol / Diesel Engine test rig to find heat balance sheet.
10. Exhaust gas analyzer.
11. Smoke meter.



DIPLOMA IN AUTOMOBILE ENGINEERING

L-SCHEME

2011-2012

22147 - INDUSTRIAL AUTOMATION PRACTICAL

DIRECTORATE OF TECHNICAL EDUCATION

GOVERNMENT OF TAMILNADU

L-SCHEME
(Implements from the Academic year 2011-2012 onwards)

Course Name : DIPLOMA IN AUTOMOBILE ENGINEERING
Course Code : 1021
Subject Code : 22147
Semester : IV
Subject Title : **INDUSTRIAL AUTOMATION PRACTICAL**

TEACHING AND SCHEME OF EXAMINATIONS:

No. of Weeks per Semester : 16 Weeks

Subject	Instructions		Examination			Duration
	Hours/Week	Hours/Semester	Marks			
INDUSTRIAL AUTOMATION PRACTICAL	4	64	Internal Assessment	Board Examination	Total	3 Hrs
			25	75	100	

Note: All the experiments should be completed. Any one experiment should be given for the examination. Students should be given the components required for the experiment. They have to draw circuit and after making necessary corrections they should be allowed to fix the components in the board for proper verification and function of the circuit.

PNEUMATICS LAB

1. Direct operation of a single acting cylinder and a double acting cylinder.
2. Operations of single acting cylinder controlled from two different positions using shuttle valve.
3. Operation of a double acting cylinder with quick exhaust valve.
4. Speed control of double acting cylinder using metering in and metering out circuit.

HYDRAULICS LAB

5. Direct operation of double acting cylinder and hydraulic motor.
6. Speed control of double acting cylinder - using metering-in and metering-out control.
7. Speed control of hydraulic motor - using metering-in and metering-out control.
8. Operation of a double acting cylinder using solenoid operated directional control valve.

PLC LAB

9. Develop ladder diagram for AND, OR logic.
10. Develop ladder diagram for ON DELAY & OFF DELAY timer circuit.
11. Develop ladder diagram for Star / Delta starter.
12. Develop ladder diagram for 4 floor lift control system.

BOARD EXAMINATION - DETAILED ALLOCATION

Circuit / Ladder diagram	-	25
Fixing in the board / Editing program	-	30
Verification of circuit	-	15
Viva – voice	-	5
TOTAL	-	75

RESOURCES REQUIRED

Minimum requirement for the sixty intakes. Based on the intake the facility should be improved.

1. Pneumatic trainer kit with air compressor – 2 Nos.
2. Hydraulic trainer kit with hydraulic power pack – 2 Nos.
3. Programmable logic controller – 2 Nos.
4. Boards to fix the component – Minimum 6 Nos.
5. Sufficient Pneumatic and Hydraulic components.

V SEMESTER



DIPLOMA IN AUTOMOBILE ENGINEERING

L-SCHEME

2011-2012

**22151 - INDUSTRIAL MANAGEMENT AND ROAD
TRANSPORT**

DIRECTORATE OF TECHNICAL EDUCATION

GOVERNMENT OF TAMILNADU

L-SCHEME
(Implements from the Academic year 2011-2012 onwards)

Course Name : DIPLOMA IN AUTOMOBILE ENGINEERING
Course Code : 1021
Subject Code : 22151
Semester : V
Subject Title : **INDUSTRIAL MANAGEMENT AND ROAD TRANSPORT ORGANISATION**

TEACHING AND SCHEME OF EXAMINATIONS:

No. of Weeks per Semester: 16 Weeks

Subject	Instructions		Examination			Duration
	Hours/Week	Hours/Semester	Marks			
INDUSTRIAL MANAGEMENT AND ROAD TRANSPORT ORGANISATION	6	96	Internal Assessment	Board Examination	Total	3 Hrs
			25	75	100	

TOPICS AND ALLOCATION OF MARKS

UNIT	TOPIC	TIME ALLOTTED (Hrs.)
I	PRINCIPLES OF MANAGEMENT AND PERSONNEL MANAGEMENT	18
II	FINANCIAL MANAGEMENT AND MATERIAL MANAGEMENT	18
III	GOODS TRANSPORT OPERATION	18
IV	PASSENGER TRANSPORT OPERATION	18
V	MOTOR VEHICLES ACT, ROAD SIGNALS AND MARKETING MANAGEMENT	18
	Test & Revision	6
TOTAL		96

Rationale

Impart knowledge on principles of management, personnel management, financial management and material management. Acquire knowledge about the goods transport and passenger transport operations. Learn the motor vehicles act and marketing management.

Objective

- To learn the principles of Management and personnel management.
- To study about the financial management and material management.
- To learn the Goods and Passenger transport operations.
- To study about the motor vehicles act and marketing management.

DETAILED SYLLABUS

Contents: Theory

UNIT	Name of the topic	Hours
I	<p>Principles of Management: Definition of management – Administration – Organisation – theories of management – F.W. Taylor's and Henry Fayol's principles – functions of manager – Planning – organizing – types of organization – line, staff, Taylor's pure functional types – line and staff and committee type-directing – leadership – types of leadership-qualities of a good leader – communication – formal and informal communication – motivation – positive and negative motivation – controlling – Just in time – Total Quality Management – Quality circle and Zero defect concept – Management Information Systems.</p> <p>Personnel Management: Responsibility of human resource management-policies and functions – selection procedure – training of workers – apprentice training, on the job training and vestibule school training – job evaluation and merit rating – objectives and importance – wages and salary administration-components of wages – wage fixation – types of wage payment- time rate systems – Halsey's 50% plan, rowan's System and Emerson's efficiency plan – problems.</p>	9 9
II	<p>Financial Management: Fixed and working capital – resources of capital – shares – types-preference and equity shares – debentures – types of debentures – public deposits, factory costing –direct cost – indirect cost-factory over head – fixation of selling price of a product – profit – problems-depreciation-causes-methods-straight line, sinking fund and percentage on diminishing value method – problems.</p> <p>Material Management: Objectives of a good stock control system-ABC analysis of inventory – procurement and consumption cycle-safety stock-re-order level – lead time – Economic order quality – problems – purchasing procedure – store keeping – Bin card.</p>	9 9
III	<p>Goods Transport Operation: Simple layout of garages and depot for goods transport vehicle-materials Handling equipments in the goods vehicle depot-Receipt of goods, delivery of goods, insurance of goods and vehicles-settlement of claims-drivers duty schedules-vehicles schedule, log sheet-way bills and other documents – connected with goods vehicle operation-transhipments and sub contracting.</p>	18
IV	<p>Passenger Transport: administrative set up of a passenger transport organization, traffic investigation to improve services – peak hour demands – Application of C.P.M in evaluation of shortest operating distance of vehicle – classification of vehicles – express, limited stop, relief services, etc. – Fare table calculation – vehicle schedule in city service – drivers and conductors duty schedules – ticket system, trip sheet – incentive schemes for improving the service – operating cost.</p>	18
V	<p>Motor Vehicles Act, Road Signals: Motor vehicles Act and road signals – Definition of various vehicles – permit – insurance, road tax, etc. – procedure for registering a vehicle – fitness certificate – issue of non – road worthy certificate – inspection of accidents and recording – issue of driving license and conductor license – enforcement of emission norms – stage carriage – contact carriage – Mini bus definitions.</p> <p>Marketing Management: Consumer survey – salesmanship – Advertisement – channels of distribution – printing – wholesale and retail agencies – promotion – legal aspects – psychological and behavioral aspects – customer relationship – buying motive – closing the sale – market research – costing in road transport – Total cost – fixed cost – variable cost – running cost – overheads – control of costs – different methods.</p>	9 9

Text Book

- 1 O. P. Khanna, Industrial Engineering and Management, Revised Edition – 2004, Dhanpat Rai, Publications (P) Ltd., 67/4 Madras House, Daryaganj, New Delhi 110 002.
- 2 T. R. Banga & S. C. Sharma, Engineering Economics and Management, Edn. 2 - 2001, published by McGraw Hill, New Delhi.

Reference Book

- 1 Heinz Wehrich, Harold Koontz, Management, A global perspective, 10th edition ,McGraw Hill international edition 1994.
- 2 Joseph L.Massie, Essentials of Management, 4th Edition, Prentice-Hall of India, New Delhi 2004.
- 3 Goods vehicle Operation – Dunbar.
- 4 Bus Operation – Dunbar.
- 5 Tamilnadu Motor Vehicle Act 1989.

22151 - INDUSTRIAL MANAGEMENT AND ROAD TRANSPORT ORGANISATION
MODEL QUESTION PAPER - I

Time: 3 Hrs

Max Marks : 75

PART A – Answer any fifteen questions. All Questions carry equal marks. **15 x 1 = 15**

- 1 What do you mean by staffing?
- 2 Define the term Directing.
- 3 What is motivation?
- 4 Define management.
- 5 What is inventory?
- 6 What is Fixed capital?
- 7 What is a bin card?
- 8 What is working capital?
- 9 What is a Way Bill?
- 10 What is Transshipment?
- 11 What is vehicle schedule?
- 12 Why insurance is needed for goods?
- 13 What is Trip sheet?
- 14 What is meant by operating cost of vehicle?
- 15 What is CPM?
- 16 What is Trip Sheet?
- 17 What is running cost?
- 18 State any two special purpose vehicles.
- 19 What is Fixed cost?
- 20 Define Minibus.

PART B: Answer all questions

5 x 12=60

- | | | | |
|-------------|----|--|----|
| 21 A | i | What are the types of job evaluation system? | 4 |
| | ii | Explain briefly the various steps followed in selection of candidates for employment. | 8 |
| (OR) | | | |
| B | i | Explain any two responsibilities of human resource manager. | 4 |
| | ii | State the types of workers training and explain any one type with its merits and demerits. | 8 |
| 22 A | i | What is Economic order quantity? | 4 |
| | ii | State and explain the various types of shares for meeting capital needs. | 8 |
| (OR) | | | |
| B | i | Explain any two objectives of costing. | 4 |
| | ii | Explain the ABC analysis of inventory control. | 8 |
| 23 A | i | Describe any two material handling equipments. | 4 |
| | ii | Explain about material handling equipments to be maintained. | 8 |
| (OR) | | | |
| B | i | What is sub contracting? | 2 |
| | ii | Discuss the essential components of a goods vehicle garage with a suitable layout. | 10 |
| 24 A | i | How peak hour traffic is managed in cities? | 4 |
| | ii | Explain the administrative set up in a passenger transport organization. | 8 |
| (OR) | | | |
| B | I | Describe the administrative setup of a passenger transport organisation. | 4 |
| | ii | Discuss about the classification of vehicles. | 8 |
| 25 A | i | Write any two salient features of motor vehicle act 1988. | 8 |
| | ii | Write notes on driver and conductor licenses. | 4 |
| (OR) | | | |
| B | i | Name the different types of traffic signs. | 4 |
| | ii | Describe in detail the salient features of motor vehicles act 1988 | 8 |

22151 - INDUSTRIAL MANAGEMENT AND ROAD TRANSPORT ORGANISATION

MODEL QUESTION PAPER - II

Time: 3 Hrs

Max Marks : 75

PART A – Answer any fifteen questions. All Questions carry equal marks. **15 x 1 = 15**

- 1 What is zero defect concept?
- 2 Mention the types of organization.
- 3 What is wages?
- 4 What is apprentice training?
- 5 What is direct cost?
- 6 What is selling price?
- 7 What is depreciation?
- 8 What is EOQ?
- 9 What is subcontracting?
- 10 What is Transshipment?
- 11 What is log sheet?
- 12 Why insurance is needed for goods?
- 13 What is peak hour demand?
- 14 What is fare table?
- 15 What is CPM?
- 16 Classify the vehicle.
- 17 What is permit?
- 18 Who is consumer?
- 19 What is fitness certificate?
- 20 What is fixed cost?

PART B: Answer all questions

5 x 12=60

- | | | | |
|-------------|----|--|----|
| 21 A | i | Describe about positive and negative motivation. | 6 |
| | ii | Describe about management information systems. | 6 |
| (OR) | | | |
| B | i | Explain the various training of workers. | 12 |
| 22 A | i | Describe about debenture. | 4 |
| | ii | Explain the types of debenture. | 8 |
| (OR) | | | |
| B | i | Write briefly about the good stock control system. | 4 |
| | ii | Explain the ABC analysis of inventory. | 8 |
| 23 A | i | Explain the simple layout of garages. | 4 |
| | ii | Explain the material handling equipments in the goods vehicle depot. | 8 |
| (OR) | | | |
| B | i | Write briefly about the receipt and delivery of goods. | 6 |
| | ii | Describe about the settlement of claims. | 6 |
| 24 A | i | Write briefly about the traffic investigation. | 4 |
| | ii | Describe about the vehicle schedule in city services and ticket system. | 8 |
| (OR) | | | |
| B | i | Discuss about the peak hour demand. | 4 |
| | ii | Explain the incentive schemes for improving the services. | 8 |
| 25 A | i | Explain the procedure for registering a vehicle. | 6 |
| | ii | Describe about the inspection of accidents and records. | 6 |
| (OR) | | | |
| B | i | Write short notes on a) Whole sale and retail agencies. b) buying motive and c) customer relationship. | 12 |



DIPLOMA IN AUTOMOBILE ENGINEERING

L-SCHEME

2011-2012

22052 - MANUFACTURING TECHNOLOGY - II

**DIRECTORATE OF TECHNICAL EDUCATION
GOVERNMENT OF TAMILNADU**

L-SCHEME
(Implements from the Academic year 2011-2012 onwards)

Course Name : DIPLOMA IN MECHANICAL ENGINEERING
Course Code : 1020
Subject Code : 22052
Semester : V
Subject Title : **MANUFACTURING TECHNOLOGY - II**

TEACHING AND SCHEME OF EXAMINATIONS:

No. of Weeks per Semester : 16 Weeks

Subject	Instructions		Examination			Duration
	Hours/Week	Hours/Semester	Marks			
Manufacturing Technology - II	5	80	Internal Assessment	Board Examination	Total	3 Hrs
			25	75	100	

Topics and Allocation of Hours:

Unit No	Topics	Hours
I	Theory of Metal cutting, Drilling machines and Boring Machines	15
II	Reciprocating Machines	15
III	Milling machines and gear generating processes	15
IV	Abrasive Process and Broaching	15
V	Jigs & Fixtures, Press work & Non-Conventional Machining.	15
	Revision and Test	5
	Total	80

RATIONALE:

It is pertinent that those involved in the process of manufacturing should possess adequate and through knowledge about the working of conventional as well as non conventional machines to see that the process of manufacturing goes on without any hindrance. This will help the individuals to hasten and also troubleshoot the hiccups that may crop up in the process of manufacturing.

The topics included aim to inculcate in the students the skills of metal cutting, drilling, milling, grinding, generating and other machining processes which are very much essential for a technician to at promptly and with precision.

OBJECTIVES:

- Explain the working of machine tools planer, shaper and slotter.
- Compare various work holding devices
- Explain the working of machine tools drilling machine and milling machine.
- Distinguish various types of milling cutter.
- Classify the different types of grinders and grinding wheels.
- Explain the broaching operation and boring operation and their applications.
- Explain the milling procedure for spur, helical and bevel gears.
- Explain the various types of gear generating processes
- Compare the various types of jigs and fixtures.
- Explain the different types of press working operations.
- Appreciate the use of non-conventional machining processes.

MANUFACTURING TECHNOLOGY - II

DETAILED SYLLABUS

Contents: Theory

Unit	Name of the Topic	Hours
I	<p>THEORY OF METAL CUTTING, DRILLING MACHINES AND BORING MACHINES</p> <p>Theory of Metal Cutting: Cutting tool material-High carbon Steel-High Speed Steel-Stellites-Cemented carbides-ceramics-Composition and applications for the above-Single point cutting tool-nomenclature-tool life-Chip Breakers.</p> <p>Drilling Machines: Drills-flat drills-twist drills-nomenclature-types of drilling machines-bench type-floor type-radial type-gang drill-multispindle type-principle of operation in drilling-speeds and feeds for various materials-drilling holes-methods of holding drill bit-drill chucks-socket and sleeve-drilling-operation-reaming-counter sinking-counter boring-spot facing-tapping-deep hole drilling.</p> <p>Boring Machines: Boring machines-horizontal and vertical types-fine boring machines-boring tools</p>	15Hrs
II	<p>RECIPROCATING MACHINES</p> <p>Planer: Types of planers-description of double housing planer-specifications-principles of operation-drives-quick return mechanism-feed mechanism- work holding devices and special fixtures-types of tools-various operation.</p> <p>Shaper: Types of shapers-specifications-standard-plain-universal-principles of operations-drives-quick return mechanism-crank and slotted link-feed mechanism-work holding devices-Special fixture-various operations.</p> <p>Slotter: Types of slotters-specifications-method of operation-Whitworth quick return mechanism-feed mechanism-work holding devices-types of tools.</p>	15Hrs
III	<p>MILLING MACHINES AND GEAR GENERATING PROCESSES</p> <p>Milling Machines: Types-column and knee type-plain-universal milling machine-vertical milling machine-specification of milling machines-principles of operation-work and tool holding devices-arbor-stub arbor-spring collet-adapter-milling cutters-cylindrical milling cutter-slitting cutter-side milling cutter-angle milling cutter-T-slot milling cutter-woodruff milling cutter-fly cutter-nomenclature of cylindrical milling cutter-milling process-conventional milling-climb milling-milling operations-straddle milling-gang milling-vertical milling attachment.</p> <p>Generating Process: gear shaper-gear hobbing-principle of operation only-gear finishing processes-burnishing-shaving-grinding and lapping-gear materials-cast iron, steel, alloy steels, brass, bronze, aluminum and nylon.</p>	15Hrs
IV	<p>ABRASIVE PROCESS AND BROACHING</p> <p>Abrasive Process: Types and classification-specifications-rough grinding –</p>	15 Hrs

	<p>pedestal grinders- portable grinders- belt grinders-precision grinding-cylindrical grinder- centerless grinders – surface grinder- tool and cutter grinder - planetary grinders-principles of operations-grinding wheels-abrasives-natural and artificial diamond wheels-types of bonds-grit, grade and structure of wheels-wheel shapes and sizes-standard marking systems of grinding wheels-selection of grinding wheel-mounting of grinding wheels-Dressing and Truing of wheels-Balancing of grinding wheels.</p> <p>Broaching: Types of broaching machine-horizontal, vertical and continuous broaching-principles of operation-types of broaches-classification-broach tool nomenclature-broaching operations-simple examples.</p>	
V	<p>JIGS & FIXTURES, PRESS WORK & NON-CONVENTIONAL MACHINING</p> <p>Jigs And Fixtures: Definitions and concept of Jig and fixture-Advantages of jigs and fixtures-elements of jigs and fixtures-locating devices-'V' locators-fixed stop locators-adjustable stop locators-clamping devices-strap clamp, screw clamp-cam action clamp-types of jigs-box drill jig-indexing drill jig-types of fixtures-keyway milling fixture-string milling fixture.</p> <p>Press Working: Types of presses-mechanical and hydraulic presses-press tools and accessories-press working operations-bending operations-angle bending-channel bending -curling-Drawing-shearing operations - blanking, piercing, trimming-notching-lancing-shaving-parting off.</p> <p>Non-Conventional Machining Processes: Construction, working and applications of Ultrasonic machining-chemical machining-electro chemical grinding-electrical discharge machining-plasma arc machining-LASER machining-Advantages – Disadvantages.</p>	15 Hrs

- Text Book :**
- 1) Elements of Workshop Technology- Vol. I & II, Hajra Choudry & Battacharya, , Edn. 11, published by Media Promoters and Publishers Pvt. Ltd., Seervai Buildings `B', 20-G, Noshir Bharucha Marg, Mumbai 400 007 – 2007.
 - 2) Production Technology, Jain & Gupta, , Khanna Publishers, 2-B, North Market, Naisarak, New Delhi – 110 006 – 2006.

Reference Book :

- 1) Production Technology, HMT, , Edn. 18, published by Tata McGraw Hill Publishing Co. Ltd., 7, West Patel Nagar, New Delhi 110 008.
- 2) Manufacturing process, Myro N Begman, , Edn. 5, Tata McGraw Hill Publishing Co. Ltd., 7, West Patel Nagar, New Delhi 110 008.
- 3) Workshop Tech Vol I,II, III, WAJ. Chapman, published by Viva Books Pvt. Ltd., 4262/3, Ansari Road, Daryaganj, New Delhi 110 002.
- 4) Production processes, NITTTR, published by 5, Tata McGraw Hill Publishing Co. Ltd., West Patel Nagar, New Delhi 110 008.

22052 MANUFACTURING TECHNOLOGY-II

MODEL QUESTION PAPER-I

Time: 3 Hrs

Max Marks : 75

PART-A

Marks 15 x 1= 15

Answer any 15 Questions-All Questions carry equal marks.

1. Name the different chip breakers?
2. Define feed in a drilling operation?
3. Define deep hole drilling?
4. What are the principles movements of a horizontal boring machine?
5. Write any two specification of the shaper?
6. Name the type of planners?
7. Name the work holding devices used in a slotting machine?
8. What are the different table movements in universal shaper?
9. What is the function of a wood ruff milling cutter?
10. What is pressure angle in a gear drive?
11. What are the applications of cast iron as a gear material?
12. What are the principles of milling operations?
13. What is grit in grinding?
14. Name the different broaching operations?
15. What is truing?
16. Name the different feeds used in centre less grinder?
17. Define jigs?
18. Differentiate between blanking die and piercing die?
19. Expand EDM in non conventional machining processes?
20. What is lancing in a press operations?

PART-B

Marks 5 x 12=60

Answer all the questions

- 21 a) i) What are the properties of a good cutting tool material? Explain? (6)
ii) Explain with a neat sketch any three operations in a vertical boring machine? (6)
- (or)
- b) i) Explain with a neat sketch . any four operations in a drilling machine? (6)
ii) Nomenclature of a flat drill? (6)
- 22 a) i) Name the various operations in a planer. Explain any three operations? (6)
ii) Sketch and explain the automatic feed mechanism of a slotter? (6)
- (or)
- i) What is quick return mechanism? (6)
ii) Explain with a neat sketch the quick return mechanism used in a shaper? (6)

- 23 a) i) Sketch the milling processes? (6)
ii) Explain with a neat sketch the gear shaper? (6)
(or)
- b) i) Explain with a neat sketch the gear hobbling processes. Write its merits and demerits of the process? (6)
- 24 a) i) Explain with a neat sketch the planetary grinder? (6)
ii) Nomenclature of a pull broach? (6)
(or)
- b) i) BIS marking of grinding wheel. Explain? (6)
ii) Explain with a neat sketch the continuous broaching? (6)
- 25 a) i) Explain with a neat sketch the box drill figure? (6)
ii) Explain with a neat sketch the ultra sonic machining? (6)
(or)
- b) i) Name the different binding operator. Explain with a neat sketch anyone binding operator? (6)
ii) Explain with a neat sketch LASER beam maturing. Writes adapter? (6)

**22052 MANUFACTURING TECHNOLOGY - II
MODEL QUESTION PAPER – II**

Time: 3 Hrs

Max Marks : 75

PART – A

Marks 15 x 1 = 15

Answer any 15 Questions – All Questions Carry Equal Marks

1. What is 18-4-1 in H.SS?
2. What is Chip Breaker?
3. Name the tool holding devices used in drilling process,
4. Name the different types of planer.
5. Name the boring tools used in boring machine.
6. List out the any two work holding devices used in a shaper.
7. Write any two principal specification of a slotter.
8. Write the different operations in a planer.
9. Name any two types of Milling cutter.
10. What is the function of a land in the cylindrical milling cutter?
11. Write any two advance of gear hobbing.
12. Write any one application of cast iron as a gear material?
13. What is grit?
14. What is wheel balancing in the grinding process?
15. Write any one applications of pull broach.
16. What is truning?
17. What are elements of a jigs?
18. Name the material used in drill jig bushes.
19. What is bending in a press work?
20. What is Plasma?

PART – B

Marks 5 x 12=60

Answer all the Questions

- 21 a. i) What are compositions in a stellite tool. Write its application. (6)
- ii) Sketch the radial drilling machine and label the principal parts. (6)
- (or)
- b.i) List the drilling operation. Sketch and explain any 2 operations. (6)

- ii) Explain with a neat sketch the horizontal boring machine. (6)
- (or)
22. a.i) Explain with a neat sketch the quick return mechanism in – Planer. (6)
- ii) Differentiate between plain Shaper and Universal Shaper. (6)
- (or)
- b.i) Explain with a neat sketch the quick return mechanism in shaper. (6)
- ii) Write the specification of a Slotter. (6)
- 23 a.i) Nomenclature of a cylindrical milling cutter. (6)
- ii) Explain with a a neat sketch the gear shaper. (6)
- (or)
- b.i) Explain with a neat sketch the milling processes. (6)
- ii) List out the gear finishing processes. Explain with a neat sketch any two gear finishing processes. (6)
- 24 a.i) Explain with neat sketch the cylindrical grinding machine. (6)
- ii) Explain the standard marking of a grinding wheel. (6)
- (or)
- b.i) Explain with neat sketch the mounting of grinding wheel in a machine spindle (6)
- ii) Explain with neat sketch any two boring operation in a vertical boring machine.. (6)
25. a.i) Explain with neat sketch the degrees of freedom of a object in a space. (6)
- ii) Explain with a neat sketch the Electrical discharge machining. (6)
- (or)
- b)i) Explain with a neat sketch box type drill jig. (6)
- ii) Explain with a neat sketch curling operations. (6)



DIPLOMA IN AUTOMOBILE ENGINEERING

L-SCHEME

2011-2012

22153 - AUTOTRONICS

DIRECTORATE OF TECHNICAL EDUCATION

GOVERNMENT OF TAMILNADU

L-SCHEME

(Implements from the Academic year 2011-2012 onwards)

Course Name : DIPLOMA IN AUTOMOBILE ENGINEERING
Course Code : 1021
Subject Code : 22153
Semester : V
Subject Title : AUTOTRONICS

TEACHING AND SCHEME OF EXAMINATIONS:

No. of Weeks per Semester : 16 Weeks

Subject	Instructions		Examination			Duration
	Hours/ Week	Hours/ Semester	Marks			
Autotronics	5	80	Internal Assessment	Board Examination	Total	3 Hrs
			25	75	100	

TOPICS AND ALLOCATION OF MARKS

UNIT	TOPIC	TIME ALLOTTED (Hrs.)
I	BASIC ELECTRICAL AND SAFETY	15
II	GENERATOR, ALTERNATOR, REGULATOR AND STARTING MOTOR	15
III	IGNITION SYSTEM	15
IV	LIGHTING, LAMP, HORN, GAUGES AND WIRING	15
V	ELECTRONICS – COMPUTER APPLICATIONS IN AUTOMOBILE	15
	Test & Revision	5
TOTAL		80

Rationale

Impart knowledge on Basic Electrical supply and safety. Learn the working of ignition system and the electrical components in the automobiles. Acquire knowledge about the electronics applications in the automobile vehicle.

Objective

- To learn the basics of electrical and Laws.
- To study about the electrical safety and importance of the earthing.
- To study the construction and principle of DC motor and its types.
- To understand about the generator, alternator, regulator and starting motor and mechanism.
- To study about the different ignition system.
- To study about the lead acid battery and testing.
- To learn about the lighting system and its components in the automobile vehicle.
- To study the horn, wipers, screen wiper, lamps and audio systems.
- To study the electronic devices in the automobiles.
- To study about the sensors and electronic control unit.

DETAILED SYLLABUS

Contents: Theory

UNIT	Name of the topic	Hours
I	<p>Basic Electrical and Safety</p> <p>Definitions – Electric Current, Voltage and resistance – Ohms law and Kirchoffs law – electromagnetism (Definition only) Magnetic flux, flux density, magnetic field intensity, Magneto Motive Force (MMF) and magnetizing force permeability, reluctance, Faradays Laws of electromagnetic induction – Fundamentals of AC voltage and current – Peak average, RMS Value of sine wave, frequency time period, amplitude, power, power factor (definition only).</p> <p>Electrical safety measures – Importance of earthing - electric shock – care of shocks – precautions against shock.</p> <p>Principle and construction of DC motor, types of DC motors – Applications – Three Phase induction motors – squirrel cage and slip ring induction motor (construction and working principle only).</p>	7 5 3
II	<p>Generator, Alternator, Regulator and Starting motor</p> <p>Generator – Purposes – Construction – Field winding – Armature winding – Commutator – Brushes – Brush gears – Testing – Field winding – Armature – Growler testing – Brush – spring tension – Under cutting – Skimming commutator – Brush bedding.</p> <p>Alternator – Purpose – Construction – Body – Stator winding – Rotor winding – Slip rings – Brush - Advantages of alternator – trouble shooting in the alternator and armature.</p> <p>Regulator: Need for the regulator – Cut out or reverse cut out relay – Constant current and voltage regulator – compensated voltage regulator – trouble shooting in regulator – dynamo – principle.</p> <p>Starting motor – Need – Working Principle – Construction – Body – Field coil – Armature windings – Poles – Commutator and brush gears – Solenoid switch. Starting motor drive mechanism – Bendix – Over running clutch type drive & co-axial drive mechanism in the heavy vehicles – complete electrical circuits of heavy duty starting motor – First contact and second contact closing – Troubles – Causes & remedies – Electric Starting circuits in two wheelers.</p>	4 3 3 5
III	<p>Ignition system</p> <p>Ignition system – Charging System – Lighting system and Auxiliary system – Their needs.</p> <p>Lead acid battery – Purpose – Construction Chemical reaction during charging and discharging – capacity ratings – Testing – Hydrometer test – open voltmeter test – High rate discharge test – charging methods – trouble shooting in batteries – (run down – over charging – sulphation – bulging)</p> <p>Battery coil ignition system – Purpose – Components and its functions – Distributor, spark plug (types) – Condenser – Breaker point mechanism – Importance of ignition timing – Setting ignition timing – Needs and types of advance mechanism – Centrifuge – Vacuum advance mechanism. Magneto ignition system – Advantages over battery coil ignition system to magnetic coil ignition system – transistorized ignition system – Electronic ignition system – Heater plugs – Cold starting devices in diesel engines.</p>	2 4 9
IV	<p>Lighting, lamp, Horn, Gauges and wiring</p> <p>Lighting – Purpose and construction of each lamp holder bulbs – Head lamps –</p>	6

	<p>Head Lamp Beam setting and adjustments – Halogen lamps – Sealed beam, dip switch – Beam indicator – Fog lamp – Park lamp – Rear number plate lamp – Door Lamp – Pillar Lamp – Roof Lamp – Roof light – Fluorescent lamp in transport vehicles – brake light – Brake light switch – traffic indicators (Resistance & Transistor type) panel lamps.</p> <p>Horn – Construction – Working – Hum relay – Horn circuit, horn turning, Troubleshooting.</p> <p>Gauges – Fuel gauge – Oil pressure gauge – Coiling water temperature gauge – Ammeter charging indicator. Radio – Interface – Suppressors – Audio System – Wind screen wipers – Construction – Working – Trouble shooting Pneumatic type wind screen wipers.</p> <p>Wiring – Single pole – Double pole – Cable size color code – wiring harness – Cable connection – fuses – Circuit breakers – Window glass panel operating system.</p>	7 2
V	<p>Electronics – Computer Applications in Automobile</p> <p>Semi conductor materials – N type and P type – PN junction forward and reverse bias, Half wave rectifier, full wave rectifier – Zener and avalanche breakdown Transistors - Logic gates OR, AND, NOT, NOR, NAND, EXOR and EXNOR gates.</p> <p>Microprocessor control systems: Concept of CPU and computer memory used in automobiles. Sensors: pressure sensor, throttle position sensor, fuel flow sensor, thermistor sensor, oxygen sensor, speed sensors, knock detecting sensors solenoid and stepper motor. Electronic dashboard instruments - Onboard diagnosis system, security and warning system – ECU – principle and working of ECU.</p>	7 8

Text Book

- 1 Automotive electrical equipments, P.L.Kohli, Tata McGraw hill publications
- 2 Automobile Electrical and Electronics Systems, Tom Denton, Arnold, London

Reference Book

- 1 Automotive electrical equipment, A.P. Young and L.Griffidis, English language book society & New press
- 2 Automotive electrical equipment, W.H. Crouse, Mc. Graw hill book co. inc. New York
- 3 Automotive Electrical and electronic system, Bosch – SAE
- 4 Automotive Electronics and Electrical equipment by William H. Crouse and DL. Anglin, McGraw Hill company.
- 5 Modern Electrical Equipment of Automoblies, Judge. A.W. Chapman & Hall, London, 1992.
- 6 Automobile Electrical Equipment, Crouse. W.H., McGraw Hill Book Co. Inc., New York, 1980.
- 7 Automobile Engineering, KM Gupta, Umesh Publishers
- 8 Automobile Engineering, RB Gupta, Satya Prakashan, New Delhi

22153 - AUTOTRONICS

MODEL QUESTION PAPER - I

Time: 3 Hrs

Max Marks : 75

PART A – Answer any fifteen questions. All Questions carry Equal marks. **15 x 1 = 15**

- 1 Define current.
- 2 What is Ohms law?
- 3 Mention the importance of earthing.
- 4 What is electric shock?
- 5 What is the purpose of Generator?
- 6 List the advantages of alternator.
- 7 What is the need of regulator?
- 8 Mention any one troubles and remedies of starting motor,
- 9 What is hydrometer test?
- 10 What is sulphation in batteries?
- 11 State the importance of ignition timing.
- 12 What is heater plugs?
- 13 What is halogen lamp?
- 14 What is horn turning?
- 15 What is fuel gauge?
- 16 What is colour code for wiring?
- 17 What is semiconductor material?
- 18 What is forward bias?
- 19 What is the use of sensor?
- 20 Mention any two electronic instrument on the dash board.

PART B: Answer all the questions.

5 x 12=60

- | | | | | |
|------|----|--|--|---|
| 21 A | i | Write short notes on a) Peak average b) RMS value of sine wave and c) frequency time period. | 6 | |
| | ii | Explain the construction and working principle of DC motor. | 6 | |
| | | (OR) | | |
| | B | i | Describe briefly about care and precaution about electric shock. | 4 |
| | | ii | Write short notes on a) Magnetic flux b) Flux density, c) manetic field intensity and d) permeability. | 8 |
| 22 A | i | Explain the construction of alternator. | 8 | |
| | ii | Explain the trouble shooting in an alternator. | 4 | |
| | | (OR) | | |
| | B | i | Explain the construction of regulator. | 6 |
| | | ii | Explain the testing of generator. | 6 |
| 23 A | i | Explain the magneto ignition system. | 6 | |
| | ii | Explain the vacuum advance mechanism. | 6 | |
| | | (OR) | | |
| | B | i | Explain the charging methods. | 4 |
| | | ii | Explain the working of battery coil ignition system. | 8 |
| 24 A | i | Write briefly about the horn and its tuning. | 4 | |
| | ii | Explain the method of head lamp setting and adjustments. | 8 | |
| | | (OR) | | |
| | B | i | Explain the trouble shooting method of a horn. | 4 |
| | | ii | Explain the construction and working of wind screen wipers. | 8 |
| 25 A | i | Explain the principle of full wave rectifier. | 8 | |
| | ii | Explain the NOR gate with truth table, | 4 | |
| | | (OR) | | |
| | B | i | Write briefly about the dash board electronic instruments. | 4 |
| | | ii | Explain the different type of sensors. | 8 |

22153 - AUTOTRONICS

MODEL QUESTION PAPER - II

Time: 3 Hrs

Max Marks : 75

PART A – Answer any fifteen questions. All Questions carry Equal marks. **15 x 1 = 15**

- 1 Define voltage.
- 2 State Kirchoffs law?
- 3 What is earthing?
- 4 Mention the applications of DC motor?
- 5 What is the purpose of brush in generator?
- 6 List the advantages of alternator.
- 7 What is the need of dynamo?
- 8 What is rotor?
- 9 What is bulging in the battery?
- 10 What is the use of condenser?
- 11 State the importance of ignition timing.
- 12 What is advance ignition?
- 13 What is use of fog lamp?
- 14 What is parking lamp?
- 15 What is fuses?
- 16 What is wiring harness?
- 17 What is logic gates?
- 18 What is reverse bias?
- 19 What is the use of sensor?
- 20 Mention any two security and warning system.

PART B: Answer all the questions. **5 x 12=60**

- | | | | |
|------|----|---|----|
| 21 A | i | Define Electro Magnetism. Explain Faradays laws of electromagnetic induction. | 6 |
| | ii | Explain the construction and working principle of DC motor. | 6 |
| | | (OR) | |
| B | i | Write briefly about care and precaution about electric shock. | 4 |
| | ii | Explain the construction and working principle of three phase induction motor. | 8 |
| 22 A | i | Explain the construction of generator. | 8 |
| | ii | Briefly explain the growler test. | 4 |
| | | (OR) | |
| B | i | Write briefly about the dynamo. | 4 |
| | ii | Explain the working principle of bendix drive starting mechanism. | 8 |
| 23 A | i | What is purpose of spark plug? Mention its types. | 4 |
| | ii | Explain the battery coil ignition system. | 8 |
| | | (OR) | |
| B | i | Write briefly about the vacuum advance mechanism. | 4 |
| | ii | Explain the cold starting devices in diesel engines. | 8 |
| 24 A | i | Write briefly about traffic indicator panel lamps. | 4 |
| | ii | Explain the method of head lamp setting and adjustments. | 8 |
| | | (OR) | |
| B | i | Write short notes on a) Fuel gauge, b) Oil pressure gauge and c) Cooling water temperature gauge. | 12 |
| 25 A | i | Explain about the zener diode and avalanche break down transistor. | 8 |
| | ii | Describe about the half wave rectifier. | 4 |
| | | (OR) | |
| B | i | Write briefly about the fuel flow sensor. | 4 |
| | ii | Explain the working principle of ECU. | 8 |



DIPLOMA IN AUTOMOBILE ENGINEERING

L-SCHEME

2011-2012

**22171 - ALTERNATE FUELS AND ENERGY
SYSTEM**

**DIRECTORATE OF TECHNICAL EDUCATION
GOVERNMENT OF TAMILNADU**

L-SCHEME
(Implements from the Academic year 2011-2012 onwards)

Course Name : DIPLOMA IN AUTOMOBILE ENGINEERING
Course Code : 1021
Subject Code : 22171
Semester : V
Subject Title : ALTERNATE FUELS AND ENERGY SYSTEM

TEACHING AND SCHEME OF EXAMINATIONS:

No. of Weeks per Semester : 16 Weeks

Subject	Instructions		Examination			Duration
	Hours/Week	Hours/Semester	Marks			
Alternate fuels and Energy system	5	80	Internal Assessment	Board Examination	Total	3 Hrs
			25	75	100	

TOPICS AND ALLOCATION OF MARKS

UNIT	TOPIC	TIME ALLOTTED (Hrs.)
I	INTRODUCTION	15
II	ALCOHOLS	15
III	NATURAL GAS, LPG, HYDROGEN AND BIOGAS	15
IV	VEGETABLE OILS	15
V	ELECTRIC AND SOLAR POWERED VEHICLES	15
	Test & Revision	5
TOTAL		80

OBJECTIVES

At the end of the course, the student will be able to acquire knowledge of alternate fuels and the changes in the engine design for handling them and understand various energy systems for use in the automobiles.

ALTERNATE FUELS AND ENERGY SYSTEM

DETAILED SYLLABUS

UNIT	Contents	Hours
I	INTRODUCTION Estimation of petroleum reserve - World Energy Scenario - Energy Survey of India – Oil industry background and history – survey of oil consumption - Availability of petroleum products – types – uses - air craft fuels – alternate fuels – list of alternate fuels - Need for alternate fuel – Availability of alternate fuels.	15
II	ALCOHOLS Introduction - properties of alcohol as fuel - uses of alcohol fuels – alcohol availability – alcohol production – methanol – ethanol – impact of incremental vehicle cost – vehicle technology and vehicle emission – use of low level blends – vehicle emission – dedicated vehicles – fuel flexible vehicle – variable fuelled vehicle – air quality benefits of alcohol fuels – methanol vehicles – fuel characteristics – fuel additives – handling of methanol – methanol health and safety.	15
III	NATURAL GAS, LPG, HYDROGEN AND BIOGAS Availability of CNG - automotive gasoline – composition – types – properties – additives – effect of emissions - modification required in engines – performance and emission characteristics of CNG and LPG in SI & CI engines. Performance and emission for LPG – Hydrogen – Storage and handling, performance and safety aspects.	15
IV	VEGETABLE OILS Introduction - Various vegetable oils for engines – Etherification – Performance in engines – Performance and emission characteristics.	15
V	ELECTRIC AND SOLAR POWERED VEHICLES Layout of an electric vehicle – advantage and limitations – Specifications – System component, Electronic control system – High energy and power density batteries – Hybrid vehicle – Solar powered vehicles. Fuel cell vehicles.	15

Text Book

- 1 Internal combustion engine, Ramalingam. K.K., SciTech publications, Chennai, 2003.
- 2 Energy today & tomorrow, Maheswar Dayal, I & B Horish India, 1982.
- 3 Alternative Fuels Guide Book, Bechtold,R.L., SAE, 1997.

Reference Book

- 1 Power Plant Engineering, Nagpal, Khanna Publishers, 1991.
- 2 Alcohols and motor fuels progress in technology, Series No.19, SAE Publication USA 1980.
- 3 SAE Paper Nos.840367, 841156, 841333, 841334.
- 4 The properties and performance of modern alternate fuels – SAE Paper No.841210.
- 5 Automobile pollution, Dr.Saty kush, IVY Publishing House, Delhi – 110095.

22171 - ALTERNATE FUELS AND ENERGY SYSTEM

MODEL QUESTION PAPER - I

Time: 3 Hrs

Max Marks : 75

PART A – Answer any fifteen questions. All Questions carry Equal marks. **15 x 1 = 15**

- 1 What are petroleum products?
- 2 What are air craft fuels?
- 3 Mention the need of alternate fuels.
- 4 List the alternate fuels.
- 5 List the properties of alcohol.
- 6 Mention the use of low level blends.
- 7 List the methanol characteristics.
- 8 List the fuel additives.
- 9 List the composition of automotive gasoline.
- 10 What is the effect of gasoline engine emission?
- 11 What is the property of LPG?
- 12 What is the performance of LPG engine?
- 13 What is vegetable oil?
- 14 Mention the vegetable oils used as fuel.
- 15 What is etherification?
- 16 What are the emissions of vegetable oil?
- 17 Mention the advantages of electric vehicle.
- 18 What are the limitations of electric vehicle?
- 19 What is hybrid vehicle?
- 20 What is fuel cell?

PART B: Answer all questions

5 x 12=60

- 21 A Explain about the world energy scenario. 12
(OR)
B Explain about the petroleum products. 12
- 22 A i Describe about the impact of vehicle cost for alternate fuel. 4
ii Explain the fuel flexible vehicle. 8
(OR)
B i Describe about the air quality benefits of alcohol fuels. 4
ii Explain about the methanol vehicle. 8
- 23 A Explain the modification required to use engine for LPG. 12
(OR)
B i Explain about the storage and handling of hydrogen. 6
ii Explain the performance and safety aspects of hydrogen as fuel. 6
- 24 A i Explain the process of etherification. 4
ii Explain the performance of engines while using various vegetable oil as fuel. 8
(OR)
B Explain the emission characteristic of vegetable oil fuels. 12
- 25 A Explain the layout of an electric vehicle. 12
(OR)
B i Write briefly about the electronic control system. 4
ii Explain about the fuel cell vehicles. 8

22171 - ALTERNATE FUELS AND ENERGY SYSTEM

MODEL QUESTION PAPER - II

Time: 3 Hrs

Max Marks : 75

PART A – Answer any fifteen questions. All Questions carry Equal marks. **15 x 1 = 15**

- 1 Mention the availability of petroleum products?
- 2 What is alternate fuel?
- 3 Mention the use of petroleum product.
- 4 List the alternate fuels.
- 5 Mention the use of alcohol.
- 6 What is low level blends?
- 7 How is methanol handled?
- 8 List the fuel additives.
- 9 What is CNG?
- 10 List the additives in gasoline.
- 11 How is hydrogen handled?
- 12 What is the effect of CNG emission?
- 13 What are vegetable oils?
- 14 Mention the vegetable oils used as fuel.
- 15 What is etherification?
- 16 What are the emissions of vegetable oil?
- 17 Mention the advantages of electric vehicle.
- 18 What is the electric vehicle?
- 19 What is solar powered vehicle?
- 20 What is fuel cell?

PART B: Answer all questions

5 x 12=60

- | | | |
|-------------|---|----|
| 21 A | Explain about the energy survey of India and survey of oil consumption. | 12 |
| (OR) | | |
| B | Explain about the alternate fuels. | 12 |
| 22 A i | Describe about the impact of vehicle cost for alternate fuel. | 6 |
| ii | Explain the alcohol production method. | 6 |
| (OR) | | |
| B i | Describe about the methanol characteristics. | 6 |
| ii | Explain about the methanol handling method. | 6 |
| 23 A | Explain the modification required to use engine for LPG. | 12 |
| (OR) | | |
| B i | Explain the characteristics of CNG and LPG. | 6 |
| ii | Explain the performance and emission characteristic for LPG. | 6 |
| 24 A i | Explain the process of etherification. | 4 |
| ii | Explain the performance of engines while using various vegetable oil as fuel. | 8 |
| (OR) | | |
| B | Explain the various vegetable oils used as fuel. | 12 |
| 25 A | Explain the layout of an electric vehicle. | 12 |
| (OR) | | |
| B i | Write briefly about the high energy and power density batteries. | 4 |
| ii | Explain about the solar powered vehicle. | 8 |



DIPLOMA IN AUTOMOBILE ENGINEERING

L-SCHEME

2011-2012

22172 - AUTOMOBILE MAINTENANCE

**DIRECTORATE OF TECHNICAL EDUCATION
GOVERNMENT OF TAMILNADU**

L-SCHEME
(Implements from the Academic year 2011-2012 onwards)

Course Name : DIPLOMA IN AUTOMOBILE ENGINEERING
Course Code : 1021
Subject Code : 22172
Semester : V
Subject Title : AUTOMOBILE MAINTENANCE

TEACHING AND SCHEME OF EXAMINATIONS:

No. of Weeks per Semester : 16 Weeks

Subject	Instructions		Examination			Duration
	Hours/Week	Hours/Semester	Marks			
AUTOMOBILE MAINTENANCE	5	80	Internal Assessment	Board Examination	Total	3 Hrs
			25	75	100	

TOPICS AND ALLOCATION OF MARKS

UNIT	TOPIC	TIME ALLOTTED (Hrs.)
I	MAINTENANCE OF RECORDS AND SCHEDULES	15
II	ENGINE MAINTENANCE – REPAIR AND OVERHAULING	15
III	CHASSIS MAINTENANCE - REPAIR AND OVERHAULING	15
IV	ELECTRICAL SYSTEM MAINTENANCE - SERVICING AND REPAIRS	15
V	MAINTENANCE OF FUEL SYSTEM, COOLING SYSTEMS, LUBRICATION SYSTEM AND VEHICLE BODY	15
	Test & Revision	5
TOTAL		80

OBJECTIVE

At the end of the course, the students will be able to have a complete knowledge of the vehicle maintenance procedures and acquire skills in handling situations where the vehicle is likely to fail.

DETAILED SYLLABUS

UNIT	Contents	Hours
I	<p>MAINTENANCE OF RECORDS AND SCHEDULES</p> <p>Importance of maintenance - preventive (scheduled) and breakdown (unscheduled) maintenance - requirements of maintenance - preparation of check lists - Inspection schedule - maintenance of records, log sheets and other forms - safety precautions in maintenance.</p>	15
II	<p>ENGINE MAINTENANCE – REPAIR AND OVERHAULING</p> <p>Dismantling of engine components and cleaning - cleaning methods - visual and dimensional inspections - minor and major reconditioning of various components, - reconditioning methods - engine assembly - engine tune up.- special tools used for maintenance and overhauling,</p>	15
III	<p>CHASSIS MAINTENANCE - REPAIR AND OVERHAULING</p> <p>Mechanical and automotive clutch and gear box servicing and maintenance - maintenance and servicing of propeller shaft and differential system - Maintenance and servicing of suspension systems - Brake systems, types and servicing techniques.</p> <p>Steering systems, overhauling and maintenance. - Wheel alignment - , computerized alignment and wheel balancing.</p>	15
IV	<p>ELECTRICAL SYSTEM MAINTENANCE - SERVICING AND REPAIRS</p> <p>Testing methods for checking electrical components - checking batter - starter motor - charging systems - DC generator and alternator - ignitions system - lighting systems. Fault diagnosis and maintenance of modern electronic controls - checking and servicing of dash board instruments.</p>	15
V	<p>MAINTENANCE OF FUEL SYSTEM, COOLING SYSTEMS, LUBRICATION SYSTEM AND VECHICLE BODY</p> <p>Servicing and maintenance of fuel system of different types of vehicles - calibration and tuning of engine for optimum fuel supply – Maintenance of cooling systems and its components - water pump, radiator, thermostat - anticorrosion and antifreeze additives. Lubrication maintenance - lubricating oil changing - greasing of parts. Vehicle body maintenance - minor and major repairs. Door locks and window glass actuating system maintenance.</p>	15

Text Book

- 1 Fleet Management, John Doke, McGraw-Hill Co. 1984.

Reference Book

- 1 Advanced Engine Performance Diagnosis, James D Halderman, PHI - 1998.
- 2 Service Manuals from Different Vehicle Manufacturers.

22172 - AUTOMOBILE MAINTENANCE

MODEL QUESTION PAPER - I

Time: 3 Hrs

Max Marks : 75

PART A – Answer any fifteen questions. All Questions carry equal marks. **15 x 1 = 15**

- 1 List the importance of maintenance.
- 2 What is check list?
- 3 What is log sheet?
- 4 What are the requirements of maintenance?
- 5 List the methods of cleaning.
- 6 What is visual inspection?
- 7 List the special tools used for maintenance.
- 8 What is dimensional inspection?
- 9 What is wheel alignment?
- 10 What is wheel balancing?
- 11 List the troubles of propeller shaft.
- 12 List the trouble of differential system.
- 13 List the method of checking electrical components.
- 14 What is the maintenance to be done on the charging system?
- 15 How fault are diagnosed in modern electronic controls?
- 16 What are the test to be done for battery?
- 17 What is engine tuning?
- 18 What is an antifreeze additive?
- 19 What is greasing?
- 20 What is thermostat?

PART B: Answer all questions.

5 x 12=60

- | | | | | |
|-------------|----|---|--|----|
| 21 A | i | Explain the about the preparation of check list. | 4 | |
| | ii | Explain about the inspection schedule and maintenance of records. | 8 | |
| (OR) | | | | |
| | B | i | List the forms used for maintenance. | 2 |
| | | ii | Explain the schedule of maintenance. | 10 |
| 22 A | i | Explain about the dismantling of engine. | 4 | |
| | ii | Explain the minor and major reconditioning of engine. | 8 | |
| (OR) | | | | |
| | B | i | Explain the engine assembly. | 4 |
| | | ii | Explain about the overhauling of engine and engine tune up. | 8 |
| 23 A | | Explain the maintenance of gear box. | 12 | |
| (OR) | | | | |
| | B | Explain the overhauling and maintenance of steering system. | 12 | |
| 24 A | i | Explain the servicing procedure for the lighting system. | 4 | |
| | ii | Explain about the diagnosis of modern electronic controls. | 8 | |
| (OR) | | | | |
| | B | i | Explain how dash board instruments are checked for servicing. | 6 |
| | | ii | Explain the maintenance of starter motor. | 6 |
| 25 A | i | Explain the service and maintenance of a fuel system. | 8 | |
| | ii | Write briefly about the tuning of engine. | 4 | |
| (OR) | | | | |
| | B | i | Explain about the vehicle body maintenance. | 4 |
| | | ii | Explain the door lock and window glass actuating system maintenance. | 8 |

22172 - AUTOMOBILE MAINTENANCE

MODEL QUESTION PAPER - II

Time: 3 Hrs

Max Marks : 75

PART A – Answer any fifteen questions. All Questions carry equal marks. **15 x 1 = 15**

- 1 What is preventive maintenance?
- 2 List the forms used for maintenance.
- 3 What is maintenance record?
- 4 What are the safety precautions of maintenance?
- 5 Mention the engine cleaning method.
- 6 What is dimensional inspection?
- 7 What is engine tune up?
- 8 What is reconditioning?
- 9 What is computerised wheel alignment?
- 10 List the steering troubles.
- 11 List the troubles of automotive clutch.
- 12 Mention the types of brake system.
- 13 List the testing methods of electrical components.
- 14 What is the maintenance to be done on the alternator?
- 15 How are fault diagnosed in modern electronic controls?
- 16 What are the tests to be done for battery?
- 17 List the minor repair on the vehicle body.
- 18 Why lubricating oil change?
- 19 What is service to be done on the water pump?
- 20 What is anticorrosion?

PART B: Answer all questions.

5 x 12=60

- | | | | | |
|-------------|----|---|---|---|
| 21 A | i | Explain the about the preventive maintenance. | 4 | |
| | ii | Explain safety precautions in maintenance. | 8 | |
| (OR) | | | | |
| | B | i | Describe the requirement of maintenance. | 4 |
| | | ii | Explain the break down maintenance. | 8 |
| 22 A | i | Explain about the dismantling of engine and cleaning methods. | 6 | |
| | ii | Explain the about the dimensional inspections | 6 | |
| (OR) | | | | |
| | B | i | Explain about the engine tune up. | 4 |
| | | ii | Explain about the special tools used for maintenance. | 8 |
| 23 A | i | Explain about the maintenance of clutch. | 4 | |
| | ii | Explain the procedure for wheel balancing. | 8 | |
| (OR) | | | | |
| | B | i | Explain about the wheel alignment. | 6 |
| | | ii | Explain the overhauling and maintenance of differential system. | 6 |
| 24 A | i | Explain how battery is checked. | 4 | |
| | ii | Explain about the testing methods of ignition system. | 8 | |
| (OR) | | | | |
| | B | i | Explain how dash board instruments are checked for servicing. | 6 |
| | | ii | Explain the maintenance of charging system. | 6 |
| 25 A | i | Explain the service and maintenance of a cooling system. | 8 | |
| | ii | Write briefly about the tuning of engine for optimum fuel supply. | 4 | |
| (OR) | | | | |
| | B | i | Explain about the vehicle body maintenance. | 4 |
| | | ii | Explain about the lubrication maintenance and changes. | 8 |



DIPLOMA IN AUTOMOBILE ENGINEERING

L-SCHEME

2011-2012

22173 - INDUSTRIAL ROBOTICS

**DIRECTORATE OF TECHNICAL EDUCATION
GOVERNMENT OF TAMILNADU**

L-SCHEME
(Implements from the Academic year 2011-2012 onwards)

Course Name : DIPLOMA IN AUTOMOBILE ENGINEERING
Course Code : 1021
Subject Code : 22173
Semester : V
Subject Title : **INDUSTRIAL ROBOTICS**

TEACHING AND SCHEME OF EXAMINATIONS:

No. of Weeks per Semester : 16 Weeks

Subject	Instructions		Examination			Duration
	Hours/ Week	Hours/ Semester	Marks			
INDUSTRIAL ROBOTICS	5	80	Internal Assessment	Board Examination	Total	3 Hrs
			25	75	100	

TOPICS AND ALLOCATION OF MARKS

UNIT	TOPIC	TIME ALLOTTED (Hrs.)
I	AUTOMATION	15
II	SENSORS AND MACHINE VISION	15
III	ROBOT	15
IV	COMPONENTS AND PROGRAMMING	15
V	APPLICATIONS	15
	Test & Revision	5
TOTAL		80

OBJECTIVES

At the end of the course, the students will be able to have a complete knowledge about the automation and working and application of robot in the automobile Industry.

22173 - INDUSTRIAL ROBOTICS

DETAILED SYLLABUS

UNIT	Name of the topic	Hours
I	AUTOMATION Introduction to automation: Basic notations and definitions - technical and economic requisites. Automation as a means of control and inspection - Basic control system concepts - control system analysis - systems of automatic control.	15
II	SENSORS AND MACHINE VISION Sensors: Sensory equipment, range sensing - proximity sensing - touch sensing - force and torque sensing - signal conditioning equipment. Introduction to machine vision, sensing and digitizing - image processing and analysis - Applications	15
III	ROBOT Introduction to robots: Definition of robot - basic concepts - robot configurations – classification of robot - types of robot drives - basic robot motions - point to point control - continuous path control – robot anatomy – accuracy – precision – laws of robot – structure of robot.	15
IV	COMPONENTS AND PROGRAMMING Components and operations: Basic actuation mechanisms - robot actuation and feed back, manipulators –director and inverse kinematics, coordinate transformation - brief robot dynamics. Types of robot and effectors - grippers - tools as end effectors – robot end - effort interface. Robot programming: Methods - languages - capabilities and limitation - artificial intelligence – knowledge representation – search techniques - AI and robotics.	15
V	APPLICATIONS Automobile Industry Applications: Application of robots in machining - welding - assembly - material handling –loading and unloading - CIM - hostile and remote environments. Parts handling automation, products inspection automation, machine tool automation, In-plant transport automation, automatic transfer machines, assembly automation.	15

Text Book

- 1 Robotics Control Sensing, Vision and Intelligence, K. S. Fu., R. C.Gonzalez, C. S. G.Lee, McGraw Hill International Edition, 1987.

Reference Book

- 1 Industrial Robotics, Technology, Programming, and Applications, Mikell P. Groover, mitchell Weiss, McGraw Hill International Editions, 1986.
- 2 Robotic Engineering – An Integrated Approach, Richard D. Klafter, Thomas A. Chmielewski, Michael Negin, Prentice Hall Inc, Englewoods Cliffs, NJ, USA, 1989
- 3 Industrial Robots, Yu.Kozyrev,
- 4 Fundamentals of Industrial Automation, V. Tergan, I. Andreev, B. Liberman,

22173 - INDUSTRIAL ROBOTICS

MODEL QUESTION PAPER - I

Time: 3 Hrs

Max Marks : 75

PART A – Answer any fifteen questions. All Questions carry equal marks. **15 x 1 = 15**

- 1 What is automation?
- 2 List the technical requirement of automation.
- 3 What are the control systems?
- 4 List the economic requirement of automation.
- 5 What is sensor?
- 6 What is force sensor?
- 7 What is digitizing?
- 8 What is image processing?
- 9 Define robot.
- 10 List the motions of robot.
- 11 List the configuration of robot.
- 12 What is accuracy?
- 13 What is feed back?
- 14 What is end effectors?
- 15 What is effort interface?
- 16 Mention the languages of robot.
- 17 List the applications of robot.
- 18 How robot is applied in CIM?
- 19 List the application of robot in assembly automations.
- 20 How robot is applicable in remote environment.

PART B: Answer all questions

5 x 12=60

- | | | |
|--------|--|----|
| 21 A | Explain about the automation control system analysis. | 12 |
| | (OR) | |
| B | Explain the systems of automatic control. | 12 |
| 22 A i | Explain the working of proximity sensor. | 6 |
| ii | Explain the working of touch sensor. | 6 |
| | (OR) | |
| B i | Write briefly about the machine vision. | 4 |
| ii | Explain the image processing and analysis. | 8 |
| 23 A | Explain the various configurations of robot with sketches. | 12 |
| | (OR) | |
| B | Explain the robot anatomy and its motions. | 12 |
| 24 A i | Write briefly about coordinate transformation. | 4 |
| ii | Explain the different grippers used in the robot. | 8 |
| | (OR) | |
| B | Explain the robot programming methods. | 12 |
| 25 A | Explain the application of robot in machining and welding industries. | 12 |
| | (OR) | |
| B | Explain the application of robot in transfer lines and assembly automations. | 12 |

22173 - INDUSTRIAL ROBOTICS

MODEL QUESTION PAPER - II

Time: 3 Hrs

Max Marks : 75

PART A – Answer any fifteen questions. All Questions carry equal marks. **15 x 1 = 15**

- 1 Define automation?
- 2 List the economic requirement of automation.
- 3 How automation as inspection?
- 4 List the technical requirement of automation.
- 5 What is range of sensor?
- 6 What is touch sensor?
- 7 What is machine vision?
- 8 List the application of image processing?
- 9 Define robot.
- 10 List the types of robot drives.
- 11 Mention the basic robot motions.
- 12 What is precision?
- 13 What is manipulator?
- 14 What is gripper?
- 15 What is AI?
- 16 Mention the method of robot programming.
- 17 How robot is applied in the assembly?
- 18 How robot is used in CIM environment?
- 19 List the application of robot in assembly automations.
- 20 How robot is applicable in remote environment.

PART B: Answer all questions

5 x 12=60

- | | | |
|--------|---|----|
| 21 A | Explain automation as a means of control and inspection. | 12 |
| | (OR) | |
| B | Explain about the basic control system. | 12 |
| 22 A i | Explain the working of proximity sensor. | 6 |
| ii | Explain the working of touch sensor. | 6 |
| | (OR) | |
| B i | Write briefly about the machine vision. | 4 |
| ii | Explain the image processing and analysis. | 8 |
| 23 A | Explain the structure of robot with sketches. | 12 |
| | (OR) | |
| B | Explain the robot laws. | 6 |
| | Differentiate accuracy and precision. | 6 |
| 24 A i | Explain the different grippers used in the robot. | 12 |
| | (OR) | |
| B | Explain about the robot programming languages. | 12 |
| 25 A | Explain the application of robot in loading and unloading. | 12 |
| | (OR) | |
| B | Explain the application of robot in hostile and remote environment. | 12 |



DIPLOMA IN AUTOMOBILE ENGINEERING

L-SCHEME

2011-2012

22155 - AUTOTRONICS PRACTICAL

**DIRECTORATE OF TECHNICAL EDUCATION
GOVERNMENT OF TAMILNADU**

L-SCHEME
(Implements from the Academic year 2011-2012 onwards)

Course Name : DIPLOMA IN AUTOMOBILE ENGINEERING
Course Code : 1021
Subject Code : 22155
Semester : V
Subject Title : AUTOTRONICS PRACTICAL

TEACHING AND SCHEME OF EXAMINATIONS:

No. of Weeks per Semester : 16 Weeks

Subject	Instructions		Examination			Duration
	Hours/Week	Hours/Semester	Marks			
AUTOTRONICS PRACTICAL	4	64	Internal Assessment	Board Examination	Total	3 Hrs
			25	75	100	

Note: All the experiments should be conducted. Examination will be conducted for two experiments by selecting one from each part.

Part A

1. Removing, charging and replacing the BATTERY from a car.
2. Identification of various components of Ignition system. Dismantling and Overhauling of a Distributor, Setting Contact Breaker Points and Servicing of Spark Plugs.
3. Dismantling and Overhauling of a Starter Motor and a Dynamo.
4. Dismantling and Overhauling of an Alternator and Regulator.
5. Servicing and tune up of the Horn and Wiper Motor.
6. Measurement of voltage, current and resistance by using multimeter (both analog and digital) in all ranges.

Part B

1. TESTING THE BATTERY: Hydrometer Test – Open Circuit Voltage and High Rate Discharge Testing.
2. Adjust the Beam of the Head Lamp.
3. Adjust the Ignition Timing with Timing Light and Start the engine.
4. Draw the characteristics of PN diode.
5. Construction of a half wave and full wave rectifier without filter.
6. Construction of a bridge wave rectifier without a filter.
7. Verification of truth table for AND, OR, NOT, NOR, NAND, EX OR, and EX NOR gates.

BOARD EXAMINATION - DETAILED ALLOCATION

Note: Question paper should have two questions one from each part.

PART A	25
PART B	45
Viva Voice	5
TOTAL	75

Resource required

All the components should be fitted on the frame / board

Battery Charger – 1 No.

Hydrometer, Specific gravity tester – 2 Nos each

Multimeter, - 2 Nos

The following items should be available as per the requirement – minimum 10 nos. each.

Transformer, Diode, Ammeter, Voltmeter, Load resistance, Connective wires, Bread board, DRB, Capacitor etc.



DIPLOMA IN AUTOMOBILE ENGINEERING

L-SCHEME

2011-2012

**22056 - MANUFACTURING TECHNOLOGY –II
PRACTICAL**

DIRECTORATE OF TECHNICAL EDUCATION

GOVERNMENT OF TAMILNADU

L-SCHEME
(Implements from the Academic year 2011-2012 onwards)

Course Name : DIPLOMA IN AUTOMOBILE ENGINEERING
Course Code : 1021
Subject Code : 22056
Semester : V
Subject Title : **MANUFACTURING TECHNOLOGY –II PRACTICAL**

TEACHING AND SCHEME OF EXAMINATIONS:

No. of Weeks per Semester : 16 Weeks

Subject	Instructions		Examination			Duration
	Hours/Week	Hours/Semester	Marks			
Manufacturing Technology –II Practical	6	96	Internal Assessment	Board Examination	Total	3 Hrs
			25	75	100	

OBJECTIVES:

- Identify a milling machine and its parts
- Identify a cylindrical grinder, surface grinder and tool and cutter grinder
- Identify the tools and instruments used in milling.
- Handle the different types of work holding devices
- Machine a component using different machine tools.
- Calculate the indexing for a work
- Machine a gear using milling machine.
- Machine a cutting tool using Tool and Cutter grinder.
- Machine a plug gauge using Cylindrical grinding machine.

SYLLABUS

1. Introduction to milling machine and its parts.
2. Introduction to grinding machine and its parts
3. Introduction to work holding devices.
4. Types of cutter used in milling machine
5. Types of grinding wheels used in grinding machines
6. Setting of work, tools and cutters in milling and grinding machines
7. Operation performed in milling and grinding machines
8. Operation of milling and grinding machines.

EXERCISES:

1. Prepare a square block from round rod using Milling machine
2. Prepare a 'V' Block using Milling machine
3. Prepare a Groove cut using Milling machine
4. Prepare a Spur Gear using milling machine by Simple Indexing
5. Prepare a Spur Gear using milling machine by Differential Indexing
6. Prepare a Hexagon by straddle milling process using milling machine
7. Prepare a Helical Gear using milling machine
8. Prepare a Plug Gauge using Cylindrical Grinding machine
9. Prepare Progressive type Plug gauge Progressive type Plug gauge using Cylindrical Grinding machine

10. Prepare a Facing Tool using Tool and Cutter Grinder
11. Prepare a plain surface using surface Grinder
12. Prepare a Parting Tool using Tool and Cutter Grinder

Note: Sketches enclosed

Note: All dimensions in mm

Note to the faculty :-Last job of the raw material (MS Rod $\text{Ø}32 \times 33\text{mm}$, MS Rod $\text{Ø}25 \times 98\text{mm}$ and $13 \times 13 \times 75\text{mm}$ MS square rod) to be retained in student wise or batch wise .This may be verifiable at the time of Board Practical Examination by the external examiner

All Linear dimensions are in $\pm 0.5\text{mm}$ tolerance and all cylindrical dimensions $\pm 0.2\text{mm}$ tolerance except grinding operation.

I MILLING

Exercise No:1

Raw Material: $\text{Ø} 32 \times 33\text{mm}$ MS rod

Milling a maximum size of square block from a 32 mm diameter round rod

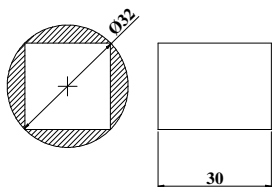

Exercise No:2-'V' Block Milling

Raw Material: Exercise No:1

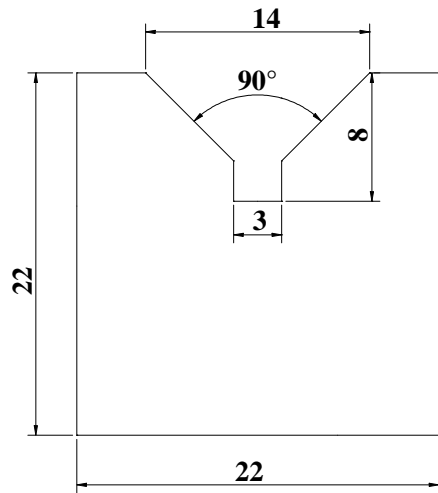

Exercise No:3- Groove Milling

Raw Material: Exercise No.2

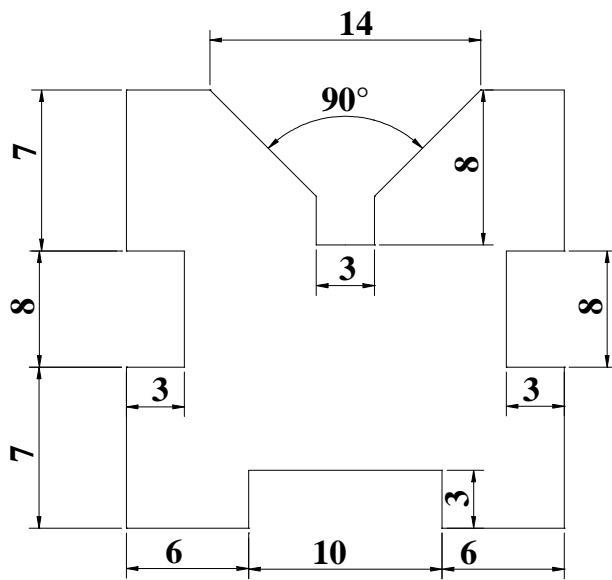

Exercise No: 4- Spur Gear milling (Simple Indexing)

Raw Material: $\varnothing 32 \times 105$ mm MS rod

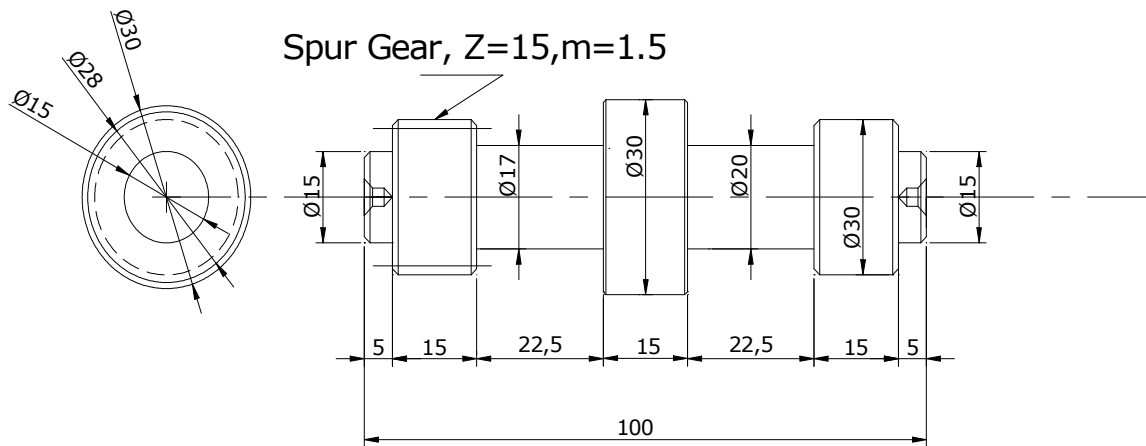

Exercise No:5- Spur Gear milling (Differential Indexing)

Raw Material: Exercise No: 4

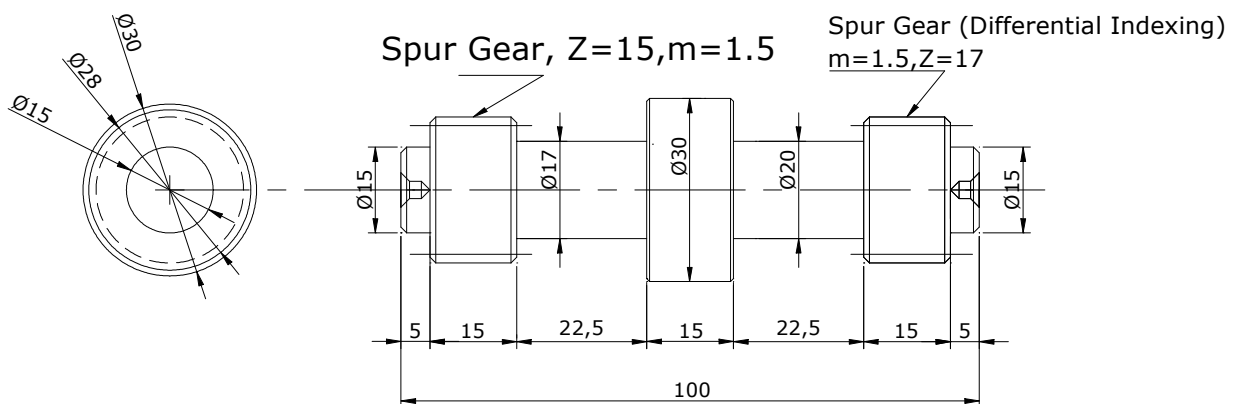

Exercise No:6- Hexagon by straddle milling process

Raw Material: Exercise No: 5

Hexagonal milling using straddle milling process

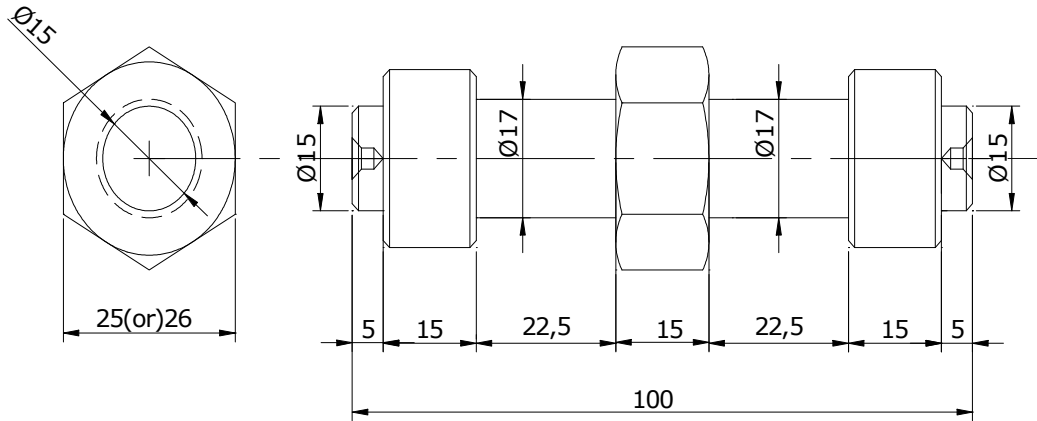

Exercise No:7- Helical Gear Milling

Raw Material: Exercise No: 6

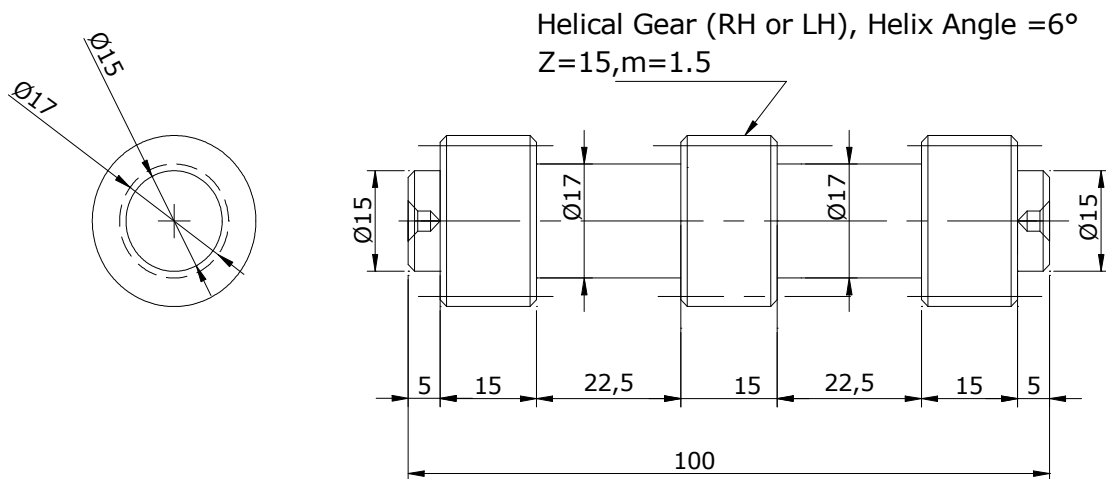

GRINDING

CYLINDRICAL GRINDING

Exercise No:8- Plug Gauge (Cylindrical Grinding)

Raw Material: Exercise No:7

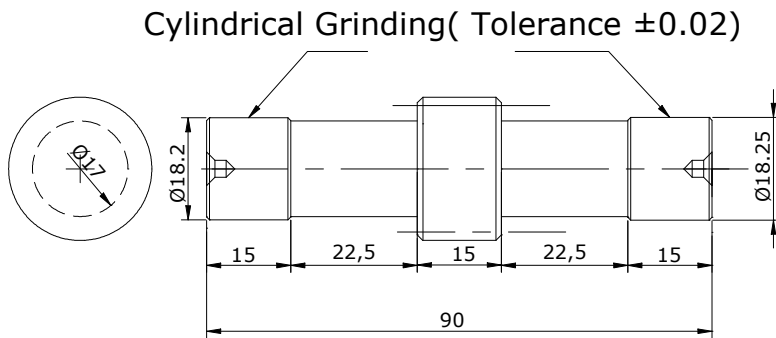

Exercise No: 9- Progressive type Plug gauge (Cylindrical Grinding)

Raw Material: Exercise No: 8

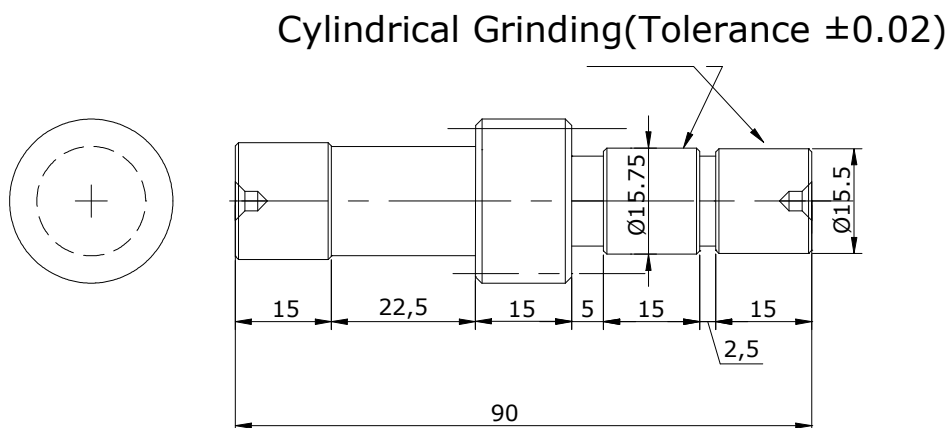

Surface Grinding

Exercise No:10- Surface Grinding

Raw Material: 13x13x75 mm MS square rod

Surface Grinding
Tolerance For 11mm side is ± 0.05

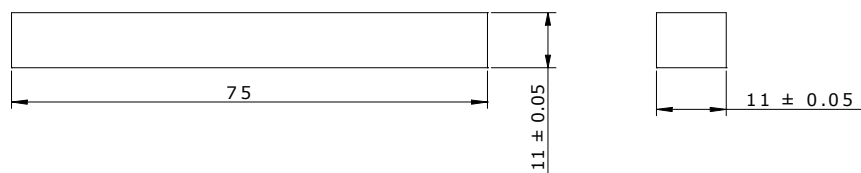

TOOL AND CUTTER GRINDING

Exercise No:11- Facing Tool (Tool and Cutter Grinder)

Raw Material: Exercise No: 10

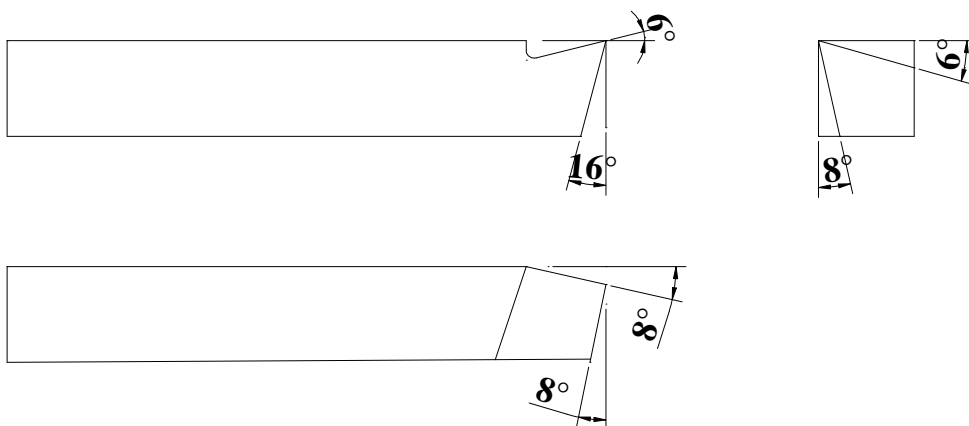

Exercise No: 12- Parting Tool (Tool and Cutter Grinder)

Raw Material: Exercise No: 11

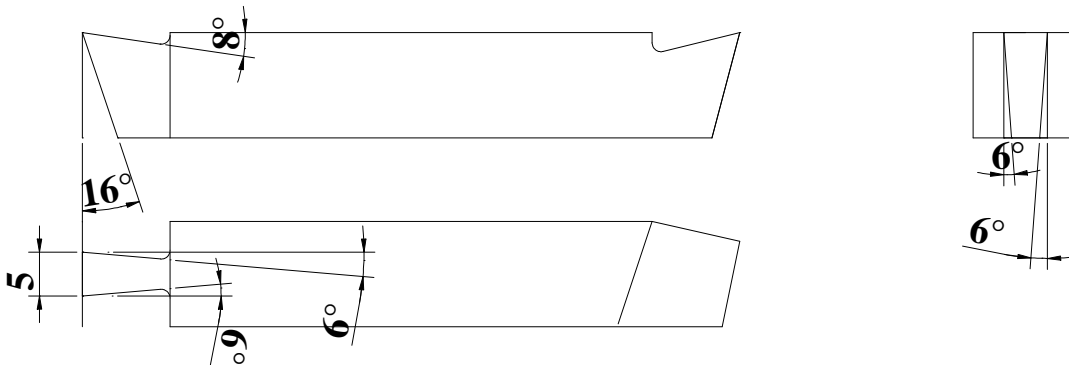

BOARD EXAMINATION

Exercise should be given either in milling or grinding in the Board Examination for 75Marks.

A. Milling Exercise

- Milling a V- block from the given round rod
- Milling a V- block & groove as in the Ex no3
- Milling a spur gear by simple indexing at the centre of the rod
- Milling a spur gear by differential indexing at the centre of the rod
- Milling a helical gear at the centre of the rod

B. Grinding Exercise

- Grinding a plug gauge
- a. Grinding a rectangular/ square using surface grinding machine and
- b. Grinding a facing tool using tool and cutter grinder
- a. Grinding a rectangular/ square using surface grinding machine and
- b. Grinding a parting tool using tool and cutter grinder

Board Examination : 75 Marks

LIST OF EQUIPMENTS

MACHINES:

1. Vertical milling machine/ vertical milling attachment in Universal Milling Machine – 2 No's
2. Universal Milling Machine with indexing head- 2 Nos
3. Surface Grinding Machine (Horizontal) – 1 No
4. Cylindrical Grinding machine – 1 No
5. Tool and Cutter grinder – 1 No

Equipments & Tools:

1. Milling Cutter (2 Module cutter) & accessories – complete sets
2. Milling Machine Handle and required accessories – 2 sets
3. Grinding wheel OD 150 mm , ID 1”(AA-65, K5, V8) – 2 No's
4. Grinding wheel OD 300 mm , ID 150mm(AA-56, K5, V8) – 1 No



DIPLOMA IN AUTOMOILE ENGINEERING

L - SCHEME

2011 - 2012

COMMUNICATION AND LIFE SKILLS PRACTICAL

**DIRECTORATE OF TECHNICAL EDUCATION
GOVERNMENT OF TAMILNADU**

L-SCHEME

(Implemented from the Academic year 2011-2012 onwards)

Course Name	:	DIPLOMA IN AUTOMOBILE ENGINEERING/TECHNOLOGY
Subject Code	:	20002
Semester	:	V SEMESTER
Subject Title	:	COMMUNICATION AND LIFE SKILLS PRACTICAL

TEACHING AND SCHEME OF EXAMINATION:

No. of Weeks per Semester: 16 Weeks

Subject	Instructions		Examination			
	Hours/Week	Hours/Semester	Marks		Duration	
COMMUNICATION AND LIFE SKILLS PRACTICAL	4	64	Internal Assessment	Board Examination	Total	3 Hrs
			25	75	100	

Topics and Allocation of Hours:

Sl. No.	Section	No. of Hours
1	Part-A:Monodic Communication	16
2	Part-B:Dyadic Communication	16
3	Part-C:Professional Communication	16
4	Part-D:Life Skills	16
	Total	64

RATIONALE

Nowadays, effective and errorfree communication is a basic need. Communication through English is the order of the day for entry and survival in any corporate. Training in Monodic communication (one man communication) Dyadic communication (a pair communication) and Professional communication (may be Monodic, Dyadic or Group communication) is attempted through these practical modules. One can improve one's communication skills by enriching one's vocabulary ,particularly active vocabulary and standard everyday expressions and using them in various contexts. Practice alone, both on the campus and outside the campus, can help a learner to grow proficient in the art of Communication.

Language is the most commonly used and effective medium of self-expression in all spheres of human life - personal, social and professional. A student must have a fair knowledge of English language use and various communicative functions. He/she must be able to pursue the present course of study and handle

the future jobs in industry. The objective of the course is to assist the diploma holders to acquire proficiency in monodic, dyadic and professional communication skills and selective but most important life skills. At the end of the course, the student will be able to communicate his ideas fearfree and errorfree, in social and professional spheres of life and imbibe life skills.

SPECIFIC INSTRUCTIONAL OBJECTIVES

Communication is crucial as it influences every aspect of one's personal development. Having a sound grounding in reading and writing techniques allows a student to progress on to higher level literacy skills. Many students struggle because their basic decoding is so inaccurate that advanced comprehension is difficult for them. Because of their poor exposure and poor use of English language in various spheres of life they suffer proper communication. They also tend to be 'afraid' of words and in turn they are not able to develop their personal vocabulary. In otherwords, without solid literacy skills, the student's prospects and life chances are limited. It is a fact that Communication skills and Life Skills shapes one's personality.

MONODIC COMMUNICATION

The student is able to:

1. Practise using departmental words and terminology in sentences.
2. Prepare and perform oral presentations.
3. Introduce oneself and others.
4. Deliver welcome address and vote of thanks.
5. Compere a program.
6. Describe the visuals.
7. Take notes, answer very short questions.
8. Comprehend an auditory/oral passage.

DYADIC COMMUNICATION

The student is able to:

1. Adopt various communicative functions.
2. Prepare and perform a dialogue.
3. Adopt the basics of telephone etiquette.

PROFESSIONAL COMMUNICAITON

The student is able to:

1. Prepare a resume.
2. Take part in a group discussion.
3. Communicate through body language.
4. Adopt the interview skills with professional presence.
5. Perform mock interview.

LIFE SKILLS

The student is able to:

1. Prepare for and deal with change.
2. Adopt motivation, goal-setting and self-esteem.
3. Adopt Teamwork skills.
4. Adopt Time management.
5. Adopt Emotional intelligence skills.
6. Assert Positively.
7. Adopt Interview etiquette.
8. Plan career.
9. Understand Strength, weakness (long term, short term).

LEARNING STRUCTURE

To enable the students to practise monodic communication, dyadic communication professional communication and imbibe life skills through various modes of practical learning and assignments.

PROCEDURE	MONODIC COMMUNICATION	DYADIC COMMUNICATION	PROFESSIONAL COMMUNICATION	LIFE SKILLS
PRINCIPLES	Identifying various platforms	Exposure to dialogue situations, exposure to telephone etiquette.	Exposure to resume writing, group discussion, interviews.	Exposure to selective life skills/problem solving skills.
CONCEPTS	Sharing opinions, feeling, with or without audience.	Understanding the basic communicative functions. Conversing with a neighbour	Writing resume, performing group discussion, facing interviews.	Imbibe and practise the selective life skills.
FACTS	Oral presentation, art of introduction, enhancing the list of active vocabulary, listening skills, note taking skills,	Audio tapes, compact disk, mikes, various contexts.	FAQ, Resume models, Audio tapes, compact disk, mikes.	Stories, anecdotes, incidences, case studies and assignments.

	describing skills.			
--	--------------------	--	--	--

COMMUNICATION AND LIFE SKILLS PRACTICAL SYLLABUS

PART A: MONODIC COMMUNICATION

(16 hours/ periods)

- a) **Vocabulary enrichment:** recording important words and terminology alphabetically connected to the concerned department – playing antakshari.
- b) **Introducing oneself:** using greeting phrases – opening and closing with courteous notes – supplying personal information.
- c) **Introducing others:** using greeting phrases – opening and closing with courteous notes – with information.
- d) **Welcome address, vote of thanks and compering a program:** keeping notes – and personal information of the dignitaries – concerned.
- e) **Making an Oral Presentation:** Preparing the presentation - Talking about people, animals and places – Keywords technique and the rehearsal – Presentation outline – Performing the presentation – answering the questions.
- f) **Oral description:** a picture from an English magazine – a visual ad – a natural scene.
- g) **Auditory/Oral comprehension** – small passage – small dialogue -very short story – note - taking skill.
- h) **News Caption:** giving caption for a news item from an English daily.

PART B: DYADIC COMMUNICATION: COMMUNICATIVE FUNCTIONS (16 hours/ periods)

- a) **Dialogue:** preparing and performing - Meeting people, exchanging greetings and taking leave – Giving instructions and seeking clarifications – Thanking someone and responding to thanks - minimum seven exchanges including the courteous openings and closings – ten common contexts.
- b) **Telephonic dialogue:** telephonic etiquette - Answering the telephone and asking for someone – Dealing with a wrong number – Taking and leaving messages – Making enquiries on the phone-ordering for supply-bookings and arrangements-handling the complaints – calling for appointment.

PART C: PROFESSIONAL COMMUNICATION

(16 hours/ periods)

- a) Group Discussion - Taking part in a Group Discussion – focus on team spirit.
- b) Interview - Frequently asked questions in an interview – Mock interview - Body language.
- c) Resume Writing – components.

PART D: LIFE SKILLS

(16 hours/ periods)

- a) Preparing for and dealing with change.
- b) Motivation, goal-setting and self-esteem.
- c) Teamwork skills.
- d) Time management
- e) Emotional intelligence skills
- f) Career planning.
- g) Assertive Skills.
- h) Interview skills.

References :-

- 1) Malcolm Goodale, Professional Presentations with VCD, Cambridge University Press
- 2) B.Jean Naterop and Rod Revell, Telephoning in English with 2 Audio CDs Cambridge University Press
- 3) Priyadarshi Patnaik, Group Discussion and Interview Skills with VCD, Cambridge University Press
- 4) Kamalesh Sadanand and Susheela Punitha, Spoken English: A Foundation Course for Speakers of Tamil, Orient BlackSwan.
- 5) S. P. Dhanavel, English and Soft Skills, Orient BlackSwan
- 6) Robert Sherfield and et al, Developing Soft Skills, Pearson Education.
- 7) Poly Skills: A course in communication skills and Life skills, Cambridge University Press.
- 8) English and Communication Skills for Students of science and Engineering by S.P.Dhanavel , Orient BlackSwan.
- 9) Speak Well, edited by Kandula Nirupa Rani, Jayashree and Indira, OrientBlackSwan.
- 10) Fifty ways to improve your telephoning and teleconferencing Skills by Ken Taylor -

COMMUNICATION AND LIFE SKILLS PRACTICAL

Model Question Paper - 1

Time: 3 hrs

Max Marks: 75

PART –A (35 Marks)

Monodic Communication:

1. Introduce one self (5)
2. Use the mentioned words orally in sentence (2x2 ½ =5)
3. Prepare and present a welcome address for your college annual day programme. (5)
4. Listen to the passage read out from the English daily of the week of the examination. Please note:
No prerecorded passage (10)
5. Write a news caption for the passage given from the English daily. (5)
6. a) Describe orally the visual or the picture found in the English daily of the week of the examination. (5)
(or)
b) Make an oral presentation about an animal.

PART – B (15 Marks)

Dyadic Communication:

1. Play antakshari of five pairs of departmental words with your partner. (5)
2. Prepare and perform a dialogue with your partner on the given situation (10)
(minimum seven exchanges)
Or
Prepare and perform a telephonic dialogue on a flight booking.
(minimum seven exchanges)

PART-C (25 Marks)

Professional Communication:

1. Form a group of six members and perform a discussion on the given theme. (10)
2. Imagine you are V.Gokulraj ,a diploma holder. Prepare a resume for the post of supervisor in Oberoi computers Ltd.Chennai. (10)

Professional appearance: Interview etiquette-dress code- Body language (5)

COMMUNICATION AND LIFE SKILLS PRACTICAL

Model Question Paper - 2

Time: 3 hrs

Max Marks: 75

PART –A (35 Marks)

Monodic Communication:

1. Introduce your friend S.Mohan an a excutive engineer to a group of audience. (5)
2. Use the mentioned words in sentence orally. (2x2 ½ =5)
3. Prepare and present a Vote of thanks in your college sports day programme. (5)
4. Listen to the passage read out from the English daily of the week of the examination. Please note:
No prerecorded passage (10)
5. Write a news caption for the passage given from the English daily. (5)
6. a) Describe the visual or the picture found in the English daily of the week of the conduct of the examination. (5)
(Or)
b) Make an oral presentation about your polytechnic college.

PART – B (15 Marks)

Dyadic Communication:

1. Play antakshari of five pairs of your departmental words with your partner. (5)
2. Prepare and perform a dialogue with your partner on the given situation (10)
(minimum seven exchanges)
(Or)

Prepare and perform a telephonic dialogue on ordering the supply of a computer
(minimum seven exchanges)

PART-C (25 Marks)

Professional Communication:

1. Form a group of six members and perform a discussion on the given theme. (10)
2. Imagine you are M.Kishore a diploma holder. Prepare a resume for the post of operating engineer in REC Electricals Ltd.Madurai. (10) **Professional appearance:** Interview etiquette-dress code- Body language (5)

NOTES OF GUIDANCE

Role of the media:

To equip a learner with vocabulary, particularly active vocabulary and standard everyday expressions, using English dailies and watching selective English T.V. channels both in the classroom and outside the classroom is focused. Such a provision is recommended for the students to establish familiarity with the English dailies and selective English T.V. channels.

Minimum two copies of two English dailies in the laboratory room (students can bring their own copies also). Minimum two systems with net connection for information collection in the laboratory itself.

Synopsis of the news item:

During every lab work day, students must choose a news item from the English daily or weekly or monthly, and write a synopsis of the chosen news item, in not more than five lines. The news item should be pasted on the left page and synopsis on the right page (the chosen news item should not be politically, socially or communally controversial). Students should exercise care in choosing the news items. Teachers have to advise them on this aspect. This can be done outside the class hours also but every record exercise should begin with the synopsis of news item of the date of the lab session.

For example, first lab exercise namely departmental vocabulary and antakshari is performed on 15/12/2011. The student should choose a news item from any English daily of 15/10/2011 and record the synopsis on the right page (in not more than 5 lines) under the caption **Synopsis of the news item of the day/date 15/10/2011**. There is no harm in repeating or copying the lines from the passage. The essence of the passage should be there. The cutout news item for presenting the synopsis should be pasted on the left page of the record notebook.

This is to be done with interest for developing one's personality. This work **does not carry any marks** but without which the record exercise should not be valued. This is the precondition for valuing the record exercise. Each record exercise follows the synopsis of the chosen news item.

At the bottom of the synopsis, the student should record the **dictionary meaning** of at least **one strange word** found in the chosen news item. At the end of every month, a minimum of 10 Headlines of 10 different days i.e. one Headline a day from any English daily should be pasted on the right or left page of the Record Note Book. (This work does not carry marks but this is the precondition for marking the record exercises)

External examiner, before signing the record notebook, should verify whether the Newspaper works were recorded/pasted in the record notebook.

Verbal communication in any language begins with sounds in isolation, union and word formation. Learning everyday words and expressions is the primary factor. Grammar comes next. One can enrich one's every day vocabulary by reading English magazines and listening to or watching an English channel on television. So an English laboratory should be equipped with a minimum of two copies of two English dailies and English weeklies or monthlies.

Watching English channels helps the students improve their vocabulary and expressions. If there is a provision, students may be permitted to watch selective, mind corruption free English channels (sports, education, news, animal channels and so on) for at least 15 min. during the English lab sessions. This will serve as motivation for the students and help them shed their inhibition.

What is antakshari? (Polar word game)

This game can be played on the stage by two or three students using the departmental words. Suppose Mr. A belongs to Dept.of Electrical and Electronics and he says his departmental word ' **ampere** 'Mr. B has to supply a word beginning with the ending letter of Mr. A's word. The word **ampere** ends with the letter ' e' so Mr. B says ' **electrical** '.Mr. A has to continue with the letter ' l '. Like that five pairs of words are to be spoken.(**Letter ending only, not sound ending.**) Suppose departmental words are not available in some English letters like ' x ' ' y ' ' z ' the students may be permitted to use common words.

ANTAKASHARI (Five Exchanges)

(Dept. of Automobile Engineering.)

EXAMPLE:

Mr. A	Mr. B
1. Governor	Reservoir
2. Rack	Kelvin
3. Nut	Tool
4. Lathe	Emission
5. Naphtha	Anvil

Introducing oneself:

One is not expected to introduce one's family. One or two sentences on his family will do. Care must be taken to include general proficiency, titles and merits, awards possessing or secured in academic activities like paper presentation, participation in inter polytechnic or intra polytechnic competitions, sports activity, forums like NCC,NSS, hobby, ambition, strengths and weaknesses.

Introducing others – merits – credentials—one or two points on his family.

Vote of thanks / Welcome address.No doubt it should be all-covering but Focus should be on the important persons/invitees/chief guest and the message of the speaker.

Description (pictures from English weekly/daily) Pictures may be displayed through projector or Magazine cuttings may be used. Just five lines on the picture will do.

Auditory/oral comprehension: A Passage from any English daily of the week of the examination is to be read out for two to three minutes in the end examination. Display of recorded passages can be used as an addition in the class room. The use of pre-recorded passage discouraged in the end examination.

Oral presentation: Students must be encouraged to use English magazines and internet for collecting information on the topic, noting keywords and use them in their presentation in his own language. One must be able to talk extempore for 2 min on any topic, given a time of two minutes for organizing his/her thoughts. The topics can be kept simple and general (current events of interest like sporting event for headline of the day). It must be totally an oral activity without the aid of any other media.

News Caption: A news item ,without heading,of not more than ten lines from an English daily of the week of the conduct of Examination is to be given. The caption may be a passive construction or a catchy phrase on the given news item.

Face to face dialogue: Selective nine situations / topics are to be performed in the class room. (Minimum seven exchanges with courteous openings and closings).

Telephonic dialogue: Selective seven situations to be given. (Minimum seven exchanges).

Resume writing: cover letter—the components of a resume like sender's address, recipient's address, career objective to be explained.

Group Discussion: Topics of common interest, avoiding controversial ones, are to be given for discussion. A group may consist of six members.

Students should be exposed to 44 phonemes (sounds) in English language and their symbols.

There shall be no question on this end examination.

COMMUNICATION SKILLS EXERCISES:-

1. Departmental Vocabulary alphabetically (using it in sentence, antakshari). Using the words orally in sentences
2. Introducing oneself and others
3. Vote of thanks / Welcome address
4. Description (pictures from English weekly/daily)
5. Auditory/oral comprehension
6. Oral presentation
7. Face to face dialogue
8. Telephonic dialogue
9. Resume writing
10. Group Discussion

Communication Skills:

Ten Marks for each exercise leading to a maximum of hundred marks in total.

The total marks to be reduced to an average of ten marks.

Texts of the performed activities to be recorded in the Record Note book. Synopsis of the news item of the day/date is mandatory at the beginning of every record exercise.

Life Skills:

- i) Preparing for and dealing with change.
- j) Motivation, goal-setting and self-esteem.
- k) Teamwork skills.
- l) Time management
- m) Emotional intelligence skills
- n) Career planning.
- o) Assertive Skills.
- p) Interview skills.

Life skills are to be intensely inculcated through lectures, quotes, anecdotes and case studies. An excellent awareness of the eight essential life skills is to be created through continuous internal assessment. Five assignments in these topics are to be recorded in the record note book.

- A minimum of five assignments on five different topics.
- Each assignment to be assessed for twenty marks.
- The total marks to be reduced to an average of ten marks.
- All the topics to be covered in the lab.

TIME MANAGEMENT IN THE END EXAM.

For written part 30 min

- Written part of the examination should be the first / beginning of the examination, monadic oral exam to start during the written exam.

Written Part exercises:

- auditory / oral comprehension.
- Resume writing.
- Giving news caption for the passage.
- During the written examination time of 30 minutes, monadic communication examination may also take place simultaneously.

MONODIC COMMUNICATION (ONE MAN COMMUNICATION)

Oral part – 75 min.

Both internal and external examiners (simultaneously) are to examine the students.

Five minutes for each student. 15 students for external & 15 students for internal and within 75 minutes both internal and external examiners complete the monadic communication exam.

DYADIC COMMUNICATION (ONE PAIR COMMUNICATION)

- 5 min for each pair.
- 15 pairs in total. 8 pairs for external and 7 pairs for internal examiner. (8x5=40 min) within **40 min** both internal and external examiners completes the dyadic communication exam.
- The students examined by the external for monadic exam are to be examined by the internal for dyadic and vice versa.

PROFESSIONAL COMMUNICATION

- 30 min for group discussion.
- 6 members in each group.
- 5 min for discussion for each group.
- Both internal and external examiners to supervise / examine simultaneously one group each.
- Within fifteen minutes all the six groups to be examined.

LABORATORY REQUIREMENT

1. An echo-free room for housing a minimum of sixty students.
2. Necessary furniture and comfortable chairs
3. Public Address System.
4. A minimum of two Computers with internet access, with Audio for Listening Skill and related software packages.
5. A minimum of Two different English dailies.
6. A minimum of one standard Tamil daily.
7. Headphone units – 30 Nos. with one control unit with a facility to play and record in Computer.
8. A minimum of Three Mikes with and without cords.
9. Colour Television (minimum size – 29”).
10. DVD/VCD Player with Home Theatre speakers.
11. Clip Chart, white board ,smart board.
12. Projector.
13. Video camera.
14. Printer,Xerox,scanner machines **desirable**.
15. English Weeklies/monthlies/journals like ELTOI **desirable**.
16. Frozen thoughts –monthly journal for Lifeskills by Mr.Rangarajan / www.frozenthoughts.com

Mark Pattern

End Examination – 75 Marks

Monodic Communication – 35 Marks

Dyadic Communication – 15 Marks

Profession Communication – 20 Marks

Professional Appearance – 5 Marks

Internal Assessment 25 Marks

Communication skills Record Notebook 10 Marks

Life skills assignments 10 Marks

Attendance 5 Marks

COMMUNICATION AND LIFE SKILLS PRACTICAL

Allocation & Statement of Marks

Duration:3Hrs.

Name of the Candidate

Reg. No.

A. Monodic communication : 35 Marks

Introduction (5 mks)	Use in sentence (5 mks)	Vote of thanks / welcome address (5 mks)	Auditory/Oral comprehension (10 mks)	Description/ Oral presentation (5 mks)	News caption (5 mks)	Total (35 mks)

B. Dyadic communication: 15 Marks

Antakshari (5 mks)	Dialogue (10 mks)	Total (15 mks)

C. Professional communication: 20 Marks

Group Discussion (10 mks)	Resume (10 mks)	Total (20 mks)

D. Internal Assessment: 25 Marks

Record Notebook Commn.skills (10 mks)	Assignments Life Skills (10 mks)	Attendance (5 mks)	Total (25 mks)

E. Professional Appearance:

/5 Marks

Total :

/100 Marks

Internal examiner

External examiner

FACE TO FACE DIALOGUE TOPICS

1. Between Friends (On any acceptable topic).
2. Between a conductor and a passenger.
3. Between a doctor and a patient.
4. Between a Shopkeeper and a Buyer.
5. Between a Teacher and a Student.
6. Between a tourist and a guide.
7. In a Bank.
- 8 At a railway enquiry counter.
9. Lodging a complaint.

Note: A resourceful teacher may add a few more topics of common interest.

TELEPHONIC DIALOGUE TOPICS

1. Placing an order.
2. Making Enquiries.
3. Fixing appointments
4. Making a hotel reservation.
5. Dealing with a wrong number.
6. Travel arrangements.
7. Handling complaints.

MECHANICAL DEPARTMENTAL VOCABULARY FOR ANTAKASHARI AND USING IN SENTENCES

EXAMPLE:

A:

1. Anvil – made of cast Iron used in foundry shop.
2. Axle – A metal rod that connects two wheels.
3. Alloy – alloy is a mixture of two or more metals.

4. Addendum – distance between top of gear teeth and pitch circle.
5. Annealing – It is a heat treatment process for softening the metals.

B:

1. Bearing – it is which supports the shaft.
2. Bolt – it is a type of fastener. Combined with screw.
3. Brake – it is used to halt an auto mobile vehicle.
4. Beed – steel wiring used in tyres to withstand stress.
5. Baffles – it is used to reduce noise, filter dust particles in auto mobile.

C:

1. Cam – it is a lobe like structure, which actuates the valve.
2. Crown – the slope like structure in the piston.
3. Calipers' – they are measuring instruments.
4. Clutch – it is used to disengage and engage the fly wheel and main shaft.
5. Chamber – it is the distance between vertical line and tyre center line.

D:

1. Damper – it is a type of shock absorber, reduces the vibration.
2. Differential – it controls the speed of rotating wheel in the rear axis.
3. Diaphragm – it is used to separate two layers.
4. Detonation – it is the continuous knocking with serious effect on cylinder head.

E:

1. Evaporator – it absorbs heat to vapourise liquid into air
2. Engine-the place where fuel is burnt and heat energy is converted. mechanical energy
3. Electrolyte-it is a liquid substance which is used to transfer current or any metal particle.
4. Emission-the release of burnt gas from automobile.
5. Elongation-the increase of dimension due to application of load.

F:

1. Filter-which is used to remove dust particles.
2. Friction-the resistance on wear occur due to rubbing of two metals.
3. Fly wheel-the wheel like structure used to balance the uneven weight in engine.
4. Fuel – it is a substance that burns with oxygen in the air.
5. Factor of safety - it is the safety limit after which the material will break down.

G:

1. Governor – it is used to control the flow of fuel according to load.
2. Gear – it is used to transmit power from one place to another.
3. Generator – it is used to generate power.
4. Gasket – it prevents the leakage and to provide sealing effect.
5. Goggle – the protective device used to guard the eyes.

H:

1. Hub – it is the center part of wheel.
2. Hammer – it is used to beat sheet metals.
3. Hydraulics – it deals with fluid for various function.
4. Hatching – it is used to highlight the parts in drawings.
5. Head stock – it is the main function unit of lathe.

I:

1. Ignition – it is the function by which fuel is burnt.
2. Injection – it is the process of spraying fuel into engine block.
3. Impeller – it is which converts kinetic energy into pressure energy.
4. Inventory – it is the place where raw materials are stored.
5. Idling – it is the condition at which the automobile engine at stationary state.

J:

1. Jig – it guides the tool and hold the job.
2. Jaw – it is teeth like structure used to hold work pieces.
3. Jog mode – Jog mode is used to give manual feed for each axis continuously.
4. Junk – it is known as waste material in industry.
5. Journal – It is a type of bearing.

K:

1. Keyway – it is a specific path made in shaft to joint parts.
2. Knocking – the sound produced due to Burning of uncompleted burnt fuel.
3. Kelvin – it is the degree of hotness.
4. Knurling – it is the process of lathe done to work piece to improve the gripness.
5. Knuckle joint – It is a type of joint used to connect two work pieces.

L:

1. Lubrication – process of reducing heat by applying cooling substances.
2. Layering – it is used to draw parts of a machine separately and combine together.
3. Lever – it is a supported arm used to engage gears.
4. Lathe – it is the father of machines used in turning operations.
5. Lead screw - it is the screw through which the carriage travels.

M:

1. Manometer – it is used to measure the pressure of fluids.
2. Milling – process of removing metal from work piece by rotating cutting tool.
3. Manifold – it is a passage made for flow of fuel in automobile.

4. Moulding – it is the process of passing hot liquid metal into mould made through sand.
5. Module – it is a metric standard used to identify or specify pitch.

N:

1. Nozzle – it is used to reduce the pressure and increases the velocity.
2. Nut – it is a type of fastener used to couple with screw.
3. Nomenclature – Dimensional property of specific part on component is notified by nomenclature.
4. Neck – Distance between drills body and shank.
5. Naphtha – kind of inflammable oil.

O:

1. Orthography – it is the three dimensional view of an object.
2. Ovality – Elliptical shape of piston.
3. Over haul – it is the complete checking and servicing of a machine or vehicle.
4. Optimum temperature – suitable temperature condition for certain process on working.
5. Offset – it is by which the axis of certain job is defined.

P:

1. Pinion – a small gear is called pinion.
2. Pulley – A cylindrical object used to connect belt for transmitting power.
3. Pump – it is which transfers fluid from one place to another.
4. Piston – it is which transfer power from combustion chamber to connecting rod.
5. Port – it is the opening in two stroke engine for movement of fuel and exhaust.

Q:

1. Quilt – it is used to give automatic feed in machines.
2. Quality control – it is an inspection processl.

R:

1. Reaming – it is the operation used to finish inner surface of a hole.
2. Reservoir – it is used to store fuel or any liquid.
3. Rack – it is a spur gear with infinite radius.
4. Retainer – it is used to bring back to the original position.
5. Radiator – it is the part used in automobile for cooling water.

S:

1. Shackle – it is a rod connected to leaf spring.
2. Spring – it is a circular rod which compresses on load and retracts when released.
3. Strainer – it is used to remove micro particles.
4. Shock absorber - it is used to reduce vibration and give cushioning effect.
5. Suspension- it is used to absorb shocks and give cushioning effect.

T:

1. Tail stock – it is used in lathe to support the job.
2. Tool – it is a metal removal device.
3. Torque – it is the twisting load given on a work piece.
4. Trimming – it is the process of removing excess metal .
5. Turning – it is a metal cutting process used to reduce diameter.

U:

1. Universal joint-it is used to connect propeller shaft and differential unit.
2. Universal divider head- it is used to index various components.

V:

1. Valve – valve is the part used in automobile for flow of fuel and exhaust to cylinder head.
2. Vent hole – it is the hole made in casting for ventilation purpose.
3. Vulcanizing – it is the process of adding carbon to rubber.
4. Vibration – it is caused due to the movement in an uneven surface.
5. Velocity-rate of change of displacement.

W:

1. Wheel-it is a circular object which rotates and moves the vehicle.
2. Wiper-it is used in wind shield to remove water droplets.
3. Work piece-it is the material in which various processes are done to make a component.
4. Wage-it is the amount paid to a worker for his work.
5. Washer-washer is a component used in fasteners to reduce gap.

Y:

1. Yawing-the turning of wind mill towards direction of air is called yawing.
2. Yoke-it is which holds the other end of spindle in milling machine.
3. Yield stress-It is the stress above which it will attain the breaking stress.
4. Young's modulus-it is the ratio between stress and strain.

Pl.note: Suppose departmental words are not available in some English letters like

' x ' ' y ' ' z ' the students may be permitted to use common words. This is only an example. Another student of Mechanical Engineering can have different sets of words under each letter of the English alphabet. Like that there may be variety of sets. The most important point is that One is not supposed to murmur but speak the words intelligibly in an audible manner. Swallowing the words will deprive a student of winning a selection in an interview. In the same way, students of other Departments can have different sets of words of their departments under each letter of the English alphabet.

TELEPHONE LANGUAGE AND PHRASES IN ENGLISH

Answering the phone

" Good morning/afternoon/evening, Madras Enterprises, Premila speaking."

" Who's calling, please?"

Introducing yourself

" This is Raghavan speaking."

" Hello, this is Raghavan from Speak International."

Asking for someone

" Could I speak to Mr. Raman, please?"

" I'd like to speak to Mr Raman, please."

" Could you put me through to Mr Raman, please?"

" Could I speak to someone who ..."

Explaining

" I'm afraid Mr. Raman isn't in at the moment".

" I'm sorry, he's in a meeting at the moment."

" I'm afraid he's on another line at the moment."

" Putting someone on hold"

" Just a moment, please."

" Could you hold the line, please?"

" Hold the line, please."

Problems

" I'm sorry, I don't understand. Could you repeat that, please?"

" I'm sorry, I can't hear you very well. Could you speak up a little, please?"

" I'm afraid you've got the wrong number."

" I've tried to get through several times but it's always engaged."

" Could you spell that, please?"

Putting someone through

" One moment, please. I'll see if Mr Raman is available."

" I'll put you through."

" I'll connect you."

" I'm connecting you now".

Taking a message

" Can I take a message?"

" Would you like to leave a message?"

" Can I give him/her a message?"

" I'll tell Mr. Raman that you called"

" I'll ask him/her to call you as soon as possible."

" Could you please leave your number? I shall ask him to get back to you."

Pl.note: The above ones are samples only. A resourceful teacher may add more.

DAY-TO-DAY EXPRESSIONS (For dialogues)

COMMON PARLANCE

How are you?

Fine. Thank you.

How are you?

Me too.

How do you do?

How do you do?

It's good to see you again.

Glad to meet you.

Thank you.

Thanks very much.

Welcome.

Hello! How is everything?

Just fine. Thanks. What's new?

Nothing much.

I'm pleased to meet you.

The pleasure is mine.

I've heard Paul speak about you often.

Only good things! I hope.

Look who's here!

Are you surprised to see me?

Sure. I thought you were in Chennai.

I was, but I got back yesterday.

Sorry, May I help you?

So kind of you.

That's so nice of you.

Nice talking to you.

Nice meeting you.

It's getting late, and I've to go now.

Certainly. Come back soon.

In that case, I'll be seeing you.
Fine.
Thank you.
Welcome
So long. See you later.
Take care. Bye.
Good-bye.

Could you tell me the time, please?
Certainly. It is 5.35 p.m.
My watch says 5.40 p.m.
Then your watch is five minutes fast.

Excuse me. Can you tell me the way to ...?
May I come in?
How is the weather today?
It is pleasant. / sunny / rainy / warm /windy.

I am sorry, Can you repeat what you have said.
I am sorry, I can't hear you properly.
It is not audible. Can you please repeat it?
Beg your pardon; I don't get your words clearly.
How do you feel now?
Are you ok?
I am fine. And how about you?
I am fine. Thank you.

GROUP DISCUSSION

Let me begin with introducing this concept,
Well, this is to convey that
At the outset, I am here to convey
At this juncture, I would like to
May I intervene?
May I add?
Kindly permit me to say
If you could allow me to say
Let me add a few words
Let me first answer your question
Can you please allow me to convey
Excuse me; I would like to add further

On behalf of my colleagues,
On their behalf
Firstly/ secondly/ thirdly.
Finally/ conclusively/ at the end / Summing up
Eventually/ in the event of
In spite of / otherwise/ although/ though

Please Note:

- The above ones are samples only.
- A resourceful teacher may add more.
- A potential student may exhibit variety.

VI SEMESTER



DIPLOMA IN AUTOMOBILE ENGINEERING

L-SCHEME

2011-2012

22161 - BODY BUILDING ENGINEERING

DIRECTORATE OF TECHNICAL EDUCATION

GOVERNMENT OF TAMILNADU

L-SCHEME
(Implements from the Academic year 2011-2012 onwards)

Course Name : DIPLOMA IN AUTOMOBILE ENGINEERING
Course Code : 1021
Subject Code : 22161
Semester : VI
Subject Title : **BODY BUILDING ENGINEERING**

TEACHING AND SCHEME OF EXAMINATIONS:

No. of Weeks per Semester : 16 Weeks

Subject	Instructions		Examination			Duration
	Hours/ Week	Hours/ Semester	Marks			
BODY BUILDING ENGINEERING	5	80	Internal Assessment	Board Examination	Total	3 Hrs
			25	75	100	

TOPICS AND ALLOCATION OF MARKS

UNIT	TOPIC	TIME ALLOTTED (Hrs.)
I	Car Body, Bus body	15
II	Vehicle Aerodynamics, Commercial Vehicle details	15
III	Body repairs	15
IV	Body Materials and Wind Noise	15
V	Painting	15
	Test & Revision	5
TOTAL		80

BODY BUILDING ENGINEERING

UNIT	Contents	Hours
I	<p>CAR BODY: Types of car bodies – saloon, convertibles, Limousine, Estate van, racing car and sports car – visibility regulations - drivers visibility tests – methods of improving visibility and space in cars – safety design, safety equipments for car body construction - safety belts - Airbags.</p> <p>BUS BODY: Types of bus bodies - mini bus, single decker, double decker two level, split level and articulated bus –Bus body lay out - Floor height engine location – entrance and exit location – constructional details. Types of metal sections used – Regulations conventional and integral type construction Modular construction.</p>	15
II	<p>VEHICLE AERODYNAMICS : Objectives – vehicle drag and types, various types of forces and moments – effects of forces and moments – various body optimization techniques for minimum drag – Wind tunnel testing – Flow visualization techniques, scale model testing. Component balance to measure forces and moments.</p> <p>COMMERCIAL VEHICLE DETAILS: Different types of commercial vehicle bodies – LCV, HCV, MCV. Light commercial vehicle body types – constructional details of flat platform body, Tipper body and Tanker body – Dimension of driver seat in relation to controls – Drivers cab design.</p>	15
III	<p>Body repair : Integral body - frame – design features of an integral body frame – safety body cell – off road vehicles – accident damage and diagnosis – before repair decisions – body repair spares. Repair procedures – minor damage vehicle repairs – repairs with washer welder – repairs with hammer and dolly – panel filling with plastic body fillers and putties – body aligning – panel replacement – outer door panel replacement – repair of plastic parts – rust repairs – surface rust repairs – repair of severely rusted panels. Corrosion protection – welded components – partial renewal – water leaks – water test – washer test – road test – test with UV lamp – special mirror test – chalk test – flow tube test – test equipment – side windows – door seal – panel connections with seal welds.</p>	15
IV	<p>Body materials: sheet metal – general characteristics of sheet metal – types of sheet metal – effects of heat on metal – rust resistant sheet metal – high strength sheet metal – glass – types – wind shield glass markings – glass installation method – resins – thermoplastic and thermosetting – sealer – Mastic adhesive sealer – body sealer and drip rail sealer – Urethane sealer.</p> <p>Wind noise: Normal air flow noises – noise caused by vibrating seals – escaping noises – cavity noises – wind noise with sliding roof open – wind noises from door seals – diagnosis – noise, vibration and harshness – types of noise in NVH technology – noise transmission through air.</p>	15
V	<p>Painting : definition – objective – elements of paint – pigments – resin – solvent – paint drying – characteristic – automobile paints – under coat paint – top coat paint – special paints – painting methods – spraying – immersion – new vehicle painting process. Repainting – types paint and repainting process – use of the spray gun - surface treatment stage – application of sanding putty – primer surface and sanding – fundamentals of colour matching – top coat preparation – degreasing and cleaning – masking – blending of hardening agents and additives – top coat process – procedure – spot repainting – drying – polishing – small repairs – waxing – defects occurring during painting – touch up your car – repairing small dent.</p>	

Text Book

- 1 Vehicle Body Engg, Powloski J, Business Books Ltd, 1989
- 2 Body repair Techniques, Anil Chhikara, Satya Prakashan , New Delhi – Vol IV

Reference Book

- 1 Body Construction & design, Giles G.J. Illiffe Books Butter worth & co
- 2 Vehicle Body Layout and analysis, John Fenton Mechanical Engg Publication Ltd London.
- 3 Paint techniques, Anil Chhikara, Satya Prakashan , New Delhi – Vol IV
- 4 Auto body repairing and repainting, Bill Toboldt, The Goodheart – Willcox Company, Inc.

22161 - BODY BUILDING ENGINEERING

MODEL QUESTION PAPER - I

Time: 3 Hrs

Max Marks : 75

PART A – Answer any fifteen questions. All Questions carry equal marks. **15 x 1 = 15**

- 1 Mention the types of car bodies.
- 2 What is convertible?
- 3 What is articulated bus?
- 4 What are the different entrance locations in the bus?
- 5 What is the objective of vehicle aerodynamic?
- 6 Name the various types of drags.
- 7 What is vehicle drag?
- 8 What is the objective of Aerodynamics?
- 9 What is body repair?
- 10 What is putty?
- 11 What is rust repair?
- 12 What is corrosion resistant?
- 13 List the characteristics of sheet metal.
- 14 Mention the types of glass.
- 15 What is wind noise?
- 16 What is harness?
- 17 Define painting.
- 18 Mention the painting methods.
- 19 What is spot repainting?
- 20 What is waxing?

PART B: Answer all questions Marks 5 x 12=60

- | | | | |
|-------------|----|---|----|
| 21 A | i | Explain the visibility tests for the driver. | 4 |
| | ii | Explain the features of racing and sports car details. | 8 |
| (OR) | | | |
| B | i | Explain the characteristics of sports car. | 2 |
| | ii | Discuss about the different types of car bodies. | 10 |
| 22 A | i | Explain about wind tunnel testing. | 4 |
| | ii | Discuss in detail about drivers seat and driver cabin in commercial vehicles. | 8 |
| (OR) | | | |
| B | i | Explain about different moments. | 4 |
| | ii | Explain in detail about the different types of commercial vehicle bodies. | 8 |
| 23 A | i | Write briefly about the accident damage and diagnosis. | 6 |
| | ii | Discuss about the before repair procedure. | 6 |
| (OR) | | | |
| B | | Explain the minor damage repair of vehicle body. | |
| 24 A | | Explain the glass installation method. | |
| (OR) | | | |
| B | | Explain the various causes and repair methods of wind noises | |
| 25 A | | Explain the different painting methods. | 12 |
| (OR) | | | |
| B | i | Explain about the fundamentals of colour matching. | 6 |
| | ii | Explain the repairing of small dents. | 6 |

22161 - BODY BUILDING ENGINEERING

MODEL QUESTION PAPER - II

Time: 3 Hrs

Max Marks : 75

PART A – Answer any fifteen questions. All Questions carry equal marks. **15 x 1 = 15**

- 1 What is the use of air bags?
- 2 What is racing car?
- 3 What is double decker bus?
- 4 What is the optimum floor height of the engine location in the bus?
- 5 What is the objective of wind tunnel testing?
- 6 List the various types of drags.
- 7 What is scale modelling test ?
- 8 Mention the objective of Aerodynamics?
- 9 What is body repair?
- 10 What is putty?
- 11 What is rust repair?
- 12 What is corrosion resistant?
- 13 List the characteristics of sheet metal.
- 14 Mention the types of glass.
- 15 What is wind noise?
- 16 What is harness?
- 17 Define painting.
- 18 Mention the painting methods.
- 19 What is spot repainting?
- 20 What is waxing?

PART B: Answer all questions Marks 5 x 12=60

- | | | | |
|-------------|----|---|----|
| 21 A | i | Explain the visibility tests for the driver. | 4 |
| | ii | Explain the features of racing and sports car details. | 8 |
| (OR) | | | |
| B | i | Explain the characteristics of sports car. | 2 |
| | ii | Discuss about the different types of car bodies. | 10 |
| 22 A | i | Explain about wind tunnel testing. | 4 |
| | ii | Discuss in detail about drivers seat and driver cabin in commercial vehicles. | 8 |
| (OR) | | | |
| B | i | Explain about different moments. | 4 |
| | ii | Explain in detail about the different types of commercial vehicle bodies. | 8 |
| 23 A | i | Write briefly about the accident damage and diagnosis. | 6 |
| | ii | Discuss about the before repair procedure. | 6 |
| (OR) | | | |
| B | | Explain the minor damage repair of vehicle body. | |
| 24 A | | Explain the glass installation method. | |
| (OR) | | | |
| B | | Explain the various causes and repair methods of wind noises | |
| 25 A | | Explain the different painting methods. | 12 |
| (OR) | | | |
| B | i | Explain about the fundamentals of colour matching. | 6 |
| | ii | Explain the repairing of small dents. | 6 |



DIPLOMA IN AUTOMOBILE ENGINEERING

L-SCHEME

2011-2012

**22062 - COMPUTER INTEGRATED
MANUFACTURING**

**DIRECTORATE OF TECHNICAL EDUCATION
GOVERNMENT OF TAMILNADU**

L-SCHEME
(Implements from the Academic year 2011-2012 onwards)

Course Name : DIPLOMA IN MECHANICAL ENGINEERING
Course Code : 1020
Subject Code : 22062
Semester : VI
Subject Title : **COMPUTER INTEGRATED MANUFACTURING**

TEACHING AND SCHEME OF EXAMINATIONS:

No. of Weeks per Semester : 16 Weeks

Subject	Instructions		Examination			Duration
	Hours/ Week	Hours/ Semester	Marks			
Computer Integrated Manufacturing	5	80	Internal Assessment	Board Examination	Total	3 Hrs
			25	75	100	

Topics and Allocation of Hours:

Unit No	Topics	Hours
I	INTRODUCTION CIM AND COMPUTER AIDED DESIGN & ANALYSIS	15
II	COMPUTER AIDED MANUFACTURING AND RAPID PROTOTYPING	15
III	CNC MACHINE AND COMPONENTS	15
IV	PART PROGRAMMING	15
V	FMS, INTEGRATED MATERIAL HANDLING AND ROBOT	15
	REVISION AND TEST	5
	Total	80

RATIONALE:

As per the latest requirements in the Industries this enables to learn the assistance of computer in the field of design and manufacturing areas. It's able to learn the latest manufacturing concepts of in the shop floors and manufacturing methods like RPT. They are able to know about the working of principles of CNC machines and programming techniques are included. The application of material handling equipments and robots are learnt based on the automation in the industries.

OBJECTIVES:

- Understand the concept and requirement of the integration of the design and manufacturing.
- Acquire knowledge about the computer assistance in the design process and analysis.
- Understand the concepts of manufacturing with computer assistance in the shop floor.
- Learn the principle and working of the CNC machines.
- Understand the principle of latest manufacturing machines like EDM and RPT.
- Learn the method of CNC programming with international codes.
- Acquire the knowledge in the material handling equipment and robot.

COMPUTER INTEGRATED MANUFACTURING

DETAILED SYLLABUS

Unit	Name of the Topic	Hours
I	<p>INTRODUCTION CIM AND COMPUTER AIDED DESIGN & ANALYSIS</p> <p>CIM: Introduction of CIM – concept of CIM - evolution of CIM – CIM wheel – Benefits – integrated CAD/CAM.</p> <p>CAD: Computer Aided Design – Introduction – CAD definition – Shigley’s design process – CAD activities – benefits of CAD. Types of CAD system –Host and terminal based CAD system - PC based CAD system – workstation based CAD system – graphics workstation – CAD software packages. 2D&3D transformations – translation, scaling, rotation and concatenation.</p> <p>Geometric modeling: Techniques: Wire frame modeling – surface modeling – solid modeling: Boundary representation – Constructive Solid Geometry – Comparison.</p> <p>Graphics standard – Definition –Need - GKS – IGES – PHIGS – DXF.</p> <p>Cost involved in design changes – Concept of Design for Excellence (DFX) – Guide lines of Design for Manufacture and assembly (DFMA).</p> <p>Finite Element Analysis: Introduction – Development - Basic steps – Advantage.</p>	15 Hrs
II	<p>COMPUTER AIDED MANUFACTURING AND RAPID PROTOTYPING</p> <p>CAM: Definition – functions of CAM – benefits of CAM – Group technology – Part families - Parts classification and coding - coding structure – Optiz system, MICLASS system and CODE System - process planning – CAPP – Types of CAPP : Variant type, Generative type – advantages of CAPP - production planning and control – computer integrated production management system – Master Production Schedule (MPS) – Capacity planning – Materials Requirement Planning (MRP) –Manufacturing Resources Planning (MRP-II)– Shop floor control system - Just in time manufacturing philosophy- Introduction to enterprises resources planning.</p> <p>Product Development Cycle – Sequential engineering – Concurrent engineering.</p> <p>Rapid proto typing: concept and applications – materials – types - Stereo lithography – laser sintering – Deposition Modeling - 3D printing.</p>	15 Hrs
III	<p>CNC MACHINE AND COMPONENTS</p> <p>CNC Machines: Numerical control – definition – components of NC systems – development of NC – DNC – Adaptive control systems – working principle of a CNC system – Features of CNC machines - advantage of CNC machines – difference between NC and CNC – Construction and working principle of turning centre – Construction and working principle of machining centers – machine axes conventions turning centre and machining centre – design considerations of NC machine tools. CNC EDM machine – Working principle of die sinking and wire EDM machines - Coordinate Measuring Machines: construction and working principles.</p> <p>Components of CNC machine.</p> <p>Drives: spindle drive – dc motor – Feed drives – dc servo motor and stepper motor – hydraulic systems – Slide ways – requirement – types – friction slide ways and anti friction slide ways - linear motion bearings – recirculation ball screw – ATC – tool magazine – feedback devices – linear and rotary transducers – Encoders - in process probing.</p>	15 Hrs

IV	<p>PART PROGRAMMING PART PROGRAMMING: NC part programming – methods - manual programming – conversational programming – APT programming - Format: sequential and word address formats - sequence number – coordinate system – types of motion control: point-to-point, paraxial and contouring – Datum points: machine zero, work zero, tool zero NC dimensioning – reference points – tool material – tool inserts - tool offsets and compensation - NC dimensioning – preparatory functions and G codes, miscellaneous functions and M codes – interpolation: linear interpolation and circular interpolation - CNC program procedure. Part Program – macro – sub-program – canned cycles: stock – mirror images – thread cutting – Sample programs for lathe : Linear and circular interpolation - Stock removal turning – Peck drilling – Thread cutting and Sample programs for milling: Linear and circular interpolation – mirroring – sub program – drilling cycle – pocketing – Generating CNC codes from CAD models – post processing</p>	15 Hrs
V	<p>FMS, INTEGRATED MATERIAL HANDLING AND ROBOT Types of manufacturing - introduction to FMS – FMS components – FMS layouts – Types of FMS: flexible manufacturing cell – flexible turning cell – flexible transfer line – flexible machining systems – benefits of FMS - introduction to intelligent manufacturing system – virtual machining. Computer Integrated material handling – AGV: working principle – types - benefits – Automatic Storage and Retrieval Systems (ASRS). ROBOT – definition – robot configurations – basic robot motion – robot programming method – robotic sensors - industrial applications: characteristics, material transfer, machine loading, welding, spray coating, assembly and inspection.</p>	15 Hrs

Text Books :

- 1) CAD/CAM/CIM , R.Radhakrishnan, S.Subramanian, New Age International Pvt. Ltd.
- 2) CAD/CAM , Mikell P.Groover, Emory Zimmers, Jr.Prentice Hall of India Pvt., Ltd.
- 3) NC Programming, S.K.Sinha, Galgotia Publications Pvt. Ltd.

Reference Books :

- 1) CAD/CAM Principles and Applications, Dr.P.N.Rao, Tata Mc Graw Hill Publishing Company Ltd.
- 2) CAD/CAM, Ibrahim Zeid, Mastering Tata McGraw-Hill Publishing Company Ltd., New Delhi.
- 3) Automation, Production Systems, and Computer-Integrated Manufacturing, Mikell P. Groover, Pearson Education Asia.
- 4) Computer control of manufacturing systems, Yoram Koren, McGraw Hill Book.

**22062 COMPUTER INTEGRATED MANUFACTURING
MODEL QUESTION PAPER-I**

Time: 3 Hrs

Max Marks : 75

PART-A

Marks 15 x 1= 15

Answer any 15 Questions-All Questions carry equal marks.

- 1 Define is CAD.
- 2 List the benefits of CIM.
- 3 What is translation?
- 4 Mention the advantages of FEA.
- 5 Define CAM.
- 6 What is process planning?
- 7 What is concurrent engineering?
- 8 Mention the applications of RPT
- 9 Define NC.
- 10 Differentiate between NC and CNC.
- 11 What is encoder?
- 12 Mention the types of slide ways.
- 13 Mention the different formats of part program.
- 14 What is reference points?
- 15 Mention the different shapes of tool inserts.
- 16 What is NC dimensioning?
- 17 List the benefits of FMS.
- 18 What is AGV?
- 19 Define robot.
- 20 List the robot programming methods.

PART – B

Marks 5 x 12=60

Answer all the Questions

- | | | |
|----|--|----|
| 21 | a i) Mention the basic steps of FEA. | 4 |
| | ii) Explain the activities of CAD in design process. | 8 |
| | (or) | |
| | b i) Compare the wire frame modeling with surface modeling. | 2 |
| | ii) Explain the constructive solid geometry modeling technique. | 10 |
| 22 | a i) Write briefly about Enterprise Resource Planning. | 4 |
| | ii) What is GT? Explain the optiz system of coding. | 8 |
| | (or) | |
| | b i) Write briefly about the Shop Floor Control. | 4 |
| | ii) Explain the computer integrated production management system. | 8 |
| 23 | a i) Explain the working of ATC. | 4 |
| | ii) Explain the working principle of turning centre. | 8 |
| | (or) | |
| | b i) What is the feed back device? | 2 |
| | ii) Explain the working of linear and rotary transducers. | 10 |
| 24 | a i) Write briefly about conversational programming. | 4 |
| | ii) Explain about the APT programming language. | 8 |
| | (or) | |
| | b i) Write the procedure to create CNC manual part program. | 4 |
| | ii) Write a part program to create a mirroring image in a CNC milling machine using a sub program. | 8 |
| 25 | a i) Explain the working principle of AGV. | 8 |
| | ii) Write briefly about ASRS. | 4 |
| | (or) | |
| | b i) Write briefly on intelligent manufacturing system. | 4 |
| | ii) Explain the different types of FMS. | 8 |

**22062 COMPUTER INTEGRATED MANUFACTURING
MODEL QUESTION PAPER-II**

Time: 3 Hrs

Max Marks : 75

PART-A

Marks 15 x 1= 15

Answer any 15 Questions-All Questions carry equal marks.

- 1 List the benefits of CAD.
- 2 What is graphic workstation?
- 3 What is concatenation?
- 4 What is the need of graphic standard?
- 5 List the benefits of CAM.
- 6 What is capacity planning?
- 7 List the advantages of CAPP.
- 8 What is sequential engineering?
- 9 What are the advantages of CNC machine?
- 10 What are the purposes of CMM?
- 11 What are the requirements of slide ways?
- 12 What is the purpose of ATC?
- 13 What is NC part programming?
- 14 What is tool offsets?
- 15 What is linear interpolation?
- 16 What is sub program?
- 17 What is FMS?
- 18 What is virtual machining?
- 19 List the types of sensors used in robot.
- 20 List the benefits of AGV

PART – B

Marks 5 x 12=60

Answer all the Questions

- | | | |
|----|---|----|
| 21 | a i) Write briefly about the cost involved in design process. | 4 |
| | ii) Explain the Shigley's design process. | 8 |
| | (or) | |
| | b i) What is graphic standard? | 2 |
| | ii) Explain the IGES graphic standard. | 10 |
| 22 | a i) Write briefly about Material Requirement Planning. | 4 |
| | ii) What is CAPP? Explain the generative method of CAPP. | 8 |
| | (or) | |
| | b i) Write briefly about the product development cycle. | 4 |
| | ii) What is RPT? Explain the working of stereo lithography. | 8 |
| 23 | a i) Write briefly about adaptive control system. | 4 |
| | ii) Explain the working principle of CNC system. | 8 |
| | (or) | |
| | b i) Write briefly about the linear motion bearing. | 2 |
| | ii) Explain the working principle of CMM. | 10 |
| 24 | a i) Write briefly about tool inserts. | 4 |
| | ii) Write a part program to make M20 X 1.5 thread in CNC lathe. | 8 |
| | (or) | |
| | b i) Explain the types of motion control in CNC machine. | 4 |
| | ii) Write a part program for stock removal in turning. | 8 |
| 25 | a i) Explain the FMS components. | 8 |
| | ii) Explain the FMS layout with sketches. | 4 |
| | (or) | |
| | b i) Write briefly about the basic robot motion. | 4 |
| | ii) Explain the different industrial applications of robot. | 8 |



DIPLOMA IN AUTOMOBILE ENGINEERING

L-SCHEME

2011-2012

**22181 - TWO AND THREE WHEELER
TECHNOLOGY**

**DIRECTORATE OF TECHNICAL EDUCATION
GOVERNMENT OF TAMILNADU**

L-SCHEME
(Implements from the Academic year 2011-2012 onwards)

Course Name : DIPLOMA IN AUTOMOBILE ENGINEERING
 Course Code : 1021
 Subject Code : 22181
 Semester : VI
 Subject Title : TWO AND THREE WHEELER TECHNOLOGY

TEACHING AND SCHEME OF EXAMINATIONS:

No. of Weeks per Semester : 16 Weeks

Subject	Instructions		Examination			Duration
	Hours/ Week	Hours/ Semester	Marks			
TWO AND THREE WHEELER TECHNOLOGY	5	80	Internal Assessment	Board Examination	Total	3 Hrs
			25	75	100	

TOPICS AND ALLOCATION OF MARKS

UNIT	TOPIC	TIME ALLOTTED (Hrs.)
I	Engines	15
II	Chassis & Sub – systems	15
III	Brakes and wheels	15
IV	Two Wheelers	15
V	Three Wheelers	15
	Test & Revision	5
TOTAL		80

TWO AND THREE WHEELER TECHNOLOGY

UNIT	Contents	Hours
I	<p>Engines</p> <p>Two stroke and four stroke SI engine – Construction and working principle -merits and demerits – Comparison - symmetrical & unsymmetrical port timing diagrams - types of scavenging processes, merits and demerits – scavenging efficiency. Scavenging pumps – Rotary valve engine – fuel system of Petrol engine – Diesel Engine – layout - types – Gravity system – Pressure system - Lubrication system – Types – Ignition system - Magneto coil and battery coil spark ignitions systems – Electronic ignition systems – Carburettor – Carburetion – Types - starting – kick starter system.</p>	
II	<p>Chassis & Sub – systems</p> <p>Main frame - types – Diamond frame – Cradle frame – Back bone frame – Under bone frame - chain and shaft drive – Clutch – purpose – types - single plate - multiple plates - centrifugal clutches –working principle - merits and demerits - gear box – purpose – Sliding mesh gear box – constant mesh gear box – construction and working principle - gear controls – front suspension system – shock absorber construction and working principle– rear suspension system – two wheeler and three wheeler - types – construction and working principle – two wheeler / three wheeler panel meters - controls on two wheeler / three wheeler handle bar.</p>	
III	<p>Brakes and wheels</p> <p>Brake – purpose – types - Drum brakes – Disc brakes –construction and working principle - two wheeler and three wheeler front and rear brake layouts – Wheels – types – construction of spokes wheel - construction of cast wheel – construction of Disc Wheel – Disc brake - Types - Tyre – functions – materials – types – construction of tubes tyre and tubeless tyres – advantages – comparison – Tubes – vulcanising - methods.</p>	
IV	<p>Two Wheelers</p> <p>Two wheeler – types – mopeds – scooters – motorcycle – race vehicle – parts – main components – Importance of maintenance – general maintenance schedule –Servicing of two wheeler – periodic checkups - Case study of different types of two Wheelers – Motor Cycles – Scooter - Moped – race vehicle - trouble shooting causes and remedies.</p>	
V	<p>Three Wheelers</p> <p>Three wheeler – types – auto rickshaw – pick up van – delivery van – trailer –main components – procedure to start – construction of three wheelers – layouts – importance of maintenance – general maintenance - - servicing manuals – periodic checkups - Case study of different types of three wheeler - Auto rickshaws - Pick up vans - Delivery Van - Trailer – Schedule of service by the different manufacturer.</p>	

Text Book

1. Irving P.E Motor Cycle Engineering. Temple Press Book London.

Reference:

1. The Cycle Motor manual Temple Press Ltd London
2. Maintenance Manuals of Leading Two & Three Wheelers Manufacturers in India.

22181 - TWO AND THREE WHEELER TECHNOLOGY

MODEL QUESTION PAPER - I

Time: 3 Hrs

Max Marks : 75

PART A – Answer any fifteen questions. All Questions carry equal marks. **15 x 1 = 15**

- 1 What is kick starter system?
- 2 What is scavenging?
- 3 What are the advantages in using four stroke engines in two wheelers?
- 4 What is caburetion?
- 5 What types of clutch is used in two wheelers?
- 6 Explain the front suspension system.
- 7 What is the use of shock absorber?
- 8 Name the controls available on the handle bar.
- 9 What is the advantage of disc brake?
- 10 What type of brakes is fitted in two and three wheelers?
- 11 What is the advantage of disc brake?
- 12 What is the recommended tyre pressure of three wheelers?
- 13 What are the advantages of motor cycles over mopeds?
- 14 List down the important components of scooter.
- 15 Name the different types of two wheelers.
- 16 Give some maintenance tips for scooter.
- 17 Name the types of three wheelers.
- 18 What are the advantages of pick up van?
- 19 What are the uses of pick up van?
- 20 What are the important components of auto rickshaw?

PART B: Answer all questions

5 x 12=60

- | | | | |
|-------------|----|--|---|
| 21 A | i | Explain the magnet coil ignition system. | 4 |
| | ii | Compare two stroke and four stroke cycle SI engines | 8 |
| (OR) | | | |
| B | i | Write briefly about the rotary valve engine. | 4 |
| | ii | Explain the Petrol and splash lubrication systems with sketches. | 8 |
| 22 A | i | What are the uses of shock absorber? | 4 |
| | ii | Explain the working of single and multiplate clutches with sketches | 8 |
| (OR) | | | |
| B | i | Describe the centrifugal clutch. | 4 |
| | ii | Describe the front and rear suspension systems for the three wheelers. | 8 |
| 23 A | i | Explain the brake link layout of a three wheeler. | 4 |
| | ii | Compare drum brakes with disc brakes. | 8 |
| (OR) | | | |
| B | i | Discuss about the types of wheels used in two and three wheelers. | 4 |
| | ii | Explain different types of wheels used in two and three wheelers. | 8 |
| 24 A | i | Compare motorcycle with scooter. | 4 |
| | ii | Explain the different components of motor cycle with their functions. | 8 |
| (OR) | | | |
| B | i | Discuss about the disc brake. | 4 |
| | ii | Discuss about the servicing and maintenance of two wheelers. | 8 |
| 25 A | i | What are the important components of delivery van? | 4 |
| | ii | Draw the layout of three wheeler and name its parts and their functions. | 8 |
| (OR) | | | |
| B | i | Explain the power transmission to wheels in Auto Rickshaws. | 4 |
| | ii | Describe the maintenance schedule of three wheeler. | 8 |

22181 - TWO AND THREE WHEELER TECHNOLOGY

MODEL QUESTION PAPER - II

Time: 3 Hrs

Max Marks : 75

PART A – Answer any fifteen questions. All Questions carry equal marks. **15 x 1 = 15**

- 1 What is kick starter system?
- 2 What is scavenging?
- 3 What are the advantages in using four stroke engines in two wheelers?
- 4 What is carburetor?
- 5 Mention type of clutch is used in two wheelers?
- 6 What are the components of front suspension system.
- 7 What is the location of shock absorber?
- 8 Name the controls available on the handle bar.
- 9 What is the advantage of disc brake?
- 10 What type of brakes is fitted in two and three wheelers?
- 11 What is the advantage of disc brake?
- 12 What is the recommended tyre pressure of three wheelers?
- 13 What are the advantages of motor cycles over mopeds?
- 14 List down the important components of scooter.
- 15 Name the different types of two wheelers.
- 16 Give some maintenance tips for scooter.
- 17 Name the types of three wheelers.
- 18 What are the advantages of pick up van?
- 19 What is picking up van?
- 20 List the components of auto rickshaw.

PART B: Answer all questions

5 x 12=60

- | | | | |
|-------------|----|--|---|
| 21 A | i | Explain the magnet coil ignition system. | 4 |
| | ii | Compare two stroke and four stroke cycle SI engines | 8 |
| (OR) | | | |
| B | i | Write briefly about the rotary valve engine. | 4 |
| | ii | Explain the Petrol and splash lubrication systems with sketches. | 8 |
| 22 A | i | What are the uses of shock absorber? | 4 |
| | ii | Explain the working of single and multiplate clutches with sketches | 8 |
| (OR) | | | |
| B | i | Describe the centrifugal clutch. | 4 |
| | ii | Describe the front and rear suspension systems for the three wheelers. | 8 |
| 23 A | i | Explain the brake link layout of a three wheeler. | 4 |
| | ii | Compare drum brakes with disc brakes. | 8 |
| (OR) | | | |
| B | i | Discuss about the types of wheels used in two and three wheelers. | 4 |
| | ii | Explain different types of wheels used in two and three wheelers. | 8 |
| 24 A | i | Compare motorcycle with scooter. | 4 |
| | ii | Explain the different components of motor cycle with their functions. | 8 |
| (OR) | | | |
| B | i | Discuss about the disc brake. | 4 |
| | ii | Discuss about the servicing and maintenance of two wheelers. | 8 |
| 25 A | i | What are the important components of delivery van? | 4 |
| | ii | Draw the layout of three wheeler and name its parts and their functions. | 8 |
| (OR) | | | |
| B | i | Explain the power transmission to wheels in Auto Rickshaws. | 4 |
| | ii | Describe the maintenance schedule of three wheeler. | 8 |



DIPLOMA IN AUTOMOBILE ENGINEERING

L-SCHEME

2011-2012

22182 - TRACTOR AND FARM EQUIPMENTS

DIRECTORATE OF TECHNICAL EDUCATION

GOVERNMENT OF TAMILNADU

L-SCHEME
(Implements from the Academic year 2011-2012 onwards)

Course Name : DIPLOMA IN AUTOMOBILE ENGINEERING
 Course Code : 1021
 Subject Code : 22182
 Semester : VI
 Subject Title : TRACTOR AND FARM EQUIPMENTS

TEACHING AND SCHEME OF EXAMINATIONS:

No. of Weeks per Semester : 16 Weeks

Subject	Instructions		Examination			Duration
	Hours/ Week	Hours/ Semester	Marks			
TRACTOR AND FARM EQUIPMENTS	5	80	Internal Assessment	Board Examination	Total	3 Hrs
			25	75	100	

TOPICS AND ALLOCATION OF MARKS

UNIT	TOPIC	TIME ALLOTTED (Hrs.)
I	General Design of Tractors and Accessories	15
II	Ploughing Implements	15
III	Harvesting and Threshing Equipments	15
IV	Sprayers and Dusters	15
V	Maintenance of Tractors	15
	Test & Revision	5
TOTAL		80

TRACTOR AND FARM EQUIPMENTS

UNIT	Contents	Hours
I	<p>General Design of Tractors and Accessories</p> <p>Classification of Tractors –Track laying tractor – heavy wheeled tractors – general purpose tractors – two wheeled tractors - Main components of Tractor – safety rules – Power Take Off Shaft – Belt pulley – Power Tiller. The tractor hydraulic system – operating principle.</p>	15
II	<p>Ploughing Implements</p> <p>Primary and Secondary Tillage equipments - DISC Plough – Mould Board Plough – Tiller and Harrows – Construction and maintenance – furrow mounted plough – plough controls - Mounting the plough – ploughing methods – systematic ploughing , round and round ploughing and one way ploughing - hitching – Three point linkage – Cage Wheel and its uses.-</p>	15
III	<p>Harvesting and Threshing Equipments</p> <p>Harvesting – conventional and Modern Harvesters – Threshing – Principle of Paddy Threshers construction and maintenance – combine – construction and advantages, disadvantages – safety precautions. Cultivation machinery – cultivators – effects and uses of cultivator – disc harrows – spring tine cultivator – seed harrows – effects and uses – chain harrows – effects and uses – rotary cultivator – uses. Corn drills – seed metering mechanisms – depth of sowing – fertilizer metering unit – checking the sowing rate. – Combine harvester – potato crop machinery – hand feed and automatic – sugar feet crop machinery.</p>	15
IV	<p>Sprayers and Dusters</p> <p>Classification of sprayers and dusters Manual and Power sprayers and Dusters – components of sprayers and dusters – different pumps, nozzles, used in sprayers – maintenance. Fertilizer distributors – rotating plate and flicker fertilizer unit – spinning disc type – the spreader mechanism – rate of application of manure. Haymaking machinery – Forage harvester – The Buckrake.</p>	15
V	<p>Maintenance of Tractors</p> <p>Daily Maintenance of Tractors – Maintenance of Tractors on hour basis – Trouble shooting of Tractor engines, clutch, Gear box – Major overhaul of engines. – Maintenance of the plough – routine maintenance of cultivating machinery – maintenance to grain drills – maintenance of fertilizer distributor – maintenance of farmyard manure spreaders.</p>	15

Text Book

1) Elements of Agricultural Engineering Jagdishwar Sahay.

Reference:

- 1) Farm Tractor – Maintenance and Repair S.C.Jain, C.T.Raj, TATA MC Graw Hill.
- 2) Farm Machinery and Equipment – Smith & Wilkey, Tata MC Graw Hill.
- 3) Farm Machinery – C.Culpin.
- 4) Basic Farm Machinery, J M Shippen and J C Turner, Pergamon International Library.- Second edition

22182 - TRACTOR AND FARM EQUIPMENTS

MODEL QUESTION PAPER - I

Time: 3 Hrs

Max Marks : 75

PART A – Answer any fifteen questions. All Questions carry equal marks. **15 x 1 = 15**

- 1 Classify the tractors.
- 2 What is the function of PTO shaft?
- 3 Explain the use of belt pulley.
- 4 What is use of power triller?
- 5 Name the different types of harrows.
- 6 What are the two types of cage wheels?
- 7 What is primary tillage?
- 8 What is the function of three point linkage?
- 9 What is the principle of threshing?
- 10 What is the advantage of combine?
- 11 Name the advantages of COMBINE?
- 12 What is use of rotary cultivator?
- 13 Classify sprayers.
- 14 What is the function of the sprayers?
- 15 Name the different pumps used in sprayers.
- 16 What is the use of spinning disc?
- 17 Why maintenance is carried out on hour basis for the tractors?
- 18 What is the cause of clutch slip?
- 19 Why air cleaner maintenance is necessary for tractors?
- 20 What is the cause of gear noise?

PART B: Answer all questions

5 x 12=60

- | | | | |
|-------------|----|--|---|
| 21 A | i | What are the uses of power tiller? | 4 |
| | ii | Explain the various components of power tiller. | 8 |
| (OR) | | | |
| B | i | Name the important components of power tiller. | 4 |
| | ii | Describe the safety rules regulations to be followed while driving and ploughing with tractor. | 8 |
| 22 A | i | Draw three-point linkage and name its parts | 4 |
| | ii | Describe the constructional details of disc plough with a sketch. | 8 |
| (OR) | | | |
| B | i | Compare the primary and secondary tillage equipments. | 4 |
| | ii | Explain the various components of spring-loaded tiller with a sketch. | 8 |
| 23 A | i | What are the safety precautions to be followed while using threshers? | 4 |
| | ii | Explain the various components of COMBINE with their functions. | 8 |
| (OR) | | | |
| B | i | Describe the operation of paddy thresher with a sketch. | 4 |
| | ii | Explain about the harvesting. Mention the advantages of using harvesters? | 8 |
| 24 A | i | List down the different types of nozzles used in power sprayer. | 4 |
| | ii | Explain about the various components and their functions of power sprayer. | 8 |
| (OR) | | | |
| B | i | Write short notes on sprayer maintenance. | 4 |
| | ii | Explain the maintenance of power sprayers and dusters. | 8 |
| 25 A | i | Why air cleaner maintenance is important for the tractor? | 8 |
| | ii | Explain the maintenance works to be carried out daily in the tractors. | 4 |
| (OR) | | | |
| B | i | What are the causes of clutch slip? | 4 |
| | ii | Discuss about major overhaul of tractor engines. | 8 |

22182 - TRACTOR AND FARM EQUIPMENTS

MODEL QUESTION PAPER - II

Time: 3 Hrs

Max Marks : 75

PART A – Answer any fifteen questions. All Questions carry Equal marks. 15 x 1 = 15

- 1 Classify the tractors.
- 2 What is the function of PTO shaft?
- 3 Explain the use of belt pulley.
- 4 What is use of power triller?
- 5 Name the different types of harrows.
- 6 What are the two types of cage wheels?
- 7 What is primary tillage?
- 8 What is the function of three point linkage?
- 9 What is the principle of threshing?
- 10 What is the advantage of combine?
- 11 Name the advantages of COMBINE?
- 12 What is use of rotary cultivator?
- 13 Classify sprayers.
- 14 What is the function of the sprayers?
- 15 Name the different pumps used in sprayers.
- 16 What is the use of spinning disc?
- 17 Why maintenance is carried out on hour basis for the tractors?
- 18 What is the cause of clutch slip?
- 19 Why air cleaner maintenance is necessary for tractors?
- 20 What is the cause of gear noise?

PART B: Answer all questions Marks 5 x 12=60

- | | | | |
|-------------|----|--|---|
| 21 A | i | What are the uses of power tiller? | 4 |
| | ii | Explain the various components of power tiller. | 8 |
| (OR) | | | |
| B | i | Name the important components of power tiller. | 4 |
| | ii | Describe the safety rules regulations to be followed while driving and ploughing with tractor. | 8 |
| 22 A | i | Draw three-point linkage and name its parts | 4 |
| | ii | Describe the constructional details of disc plough with a sketch. | 8 |
| (OR) | | | |
| B | i | Compare the primary and secondary tillage equipments. | 4 |
| | ii | Explain the various components of spring-loaded tiller with a sketch. | 8 |
| 23 A | i | What are the safety precautions to be followed while using threshers? | 4 |
| | ii | Explain the various components of COMBINE with their functions. | 8 |
| (OR) | | | |
| B | i | Describe the operation of paddy thresher with a sketch. | 4 |
| | ii | Explain about the harvesting. Mention the advantages of using harvesters? | 8 |
| 24 A | i | List down the different types of nozzles used in power sprayer. | 4 |
| | ii | Explain about the various components and their functions of power sprayer. | 8 |
| (OR) | | | |
| B | i | Write short notes on sprayer maintenance. | 4 |
| | ii | Explain the maintenance of power sprayers and dusters. | 8 |
| 25 A | i | Why air cleaner maintenance is important for the tractor? | 8 |
| | ii | Explain the maintenance works to be carried out daily in the tractors. | 4 |
| (OR) | | | |
| B | i | What are the causes of clutch slip? | 4 |
| | ii | Discuss about major overhaul of tractor engines. | 8 |



DIPLOMA IN AUTOMOBILE ENGINEERING

L-SCHEME

2011-2012

22183 - AERONAUTICS ENGINEERING

**DIRECTORATE OF TECHNICAL EDUCATION
GOVERNMENT OF TAMILNADU**

L-SCHEME
(Implements from the Academic year 2011-2012 onwards)

Course Name : DIPLOMA IN AUTOMOBILE ENGINEERING
Course Code : 1021
Subject Code : 22183
Semester : VI
Subject Title : AERONAUTICS ENGINEERING

TEACHING AND SCHEME OF EXAMINATIONS:

No. of Weeks per Semester : 16 Weeks

Subject	Instructions		Examination			Duration
	Hours/Week	Hours/Semester	Marks			
Aeronautics Engineering	5	80	Internal Assessment	Board Examination	Total	3 Hrs
			25	75	100	

TOPICS AND ALLOCATION OF MARKS

UNIT	TOPIC	TIME ALLOTTED (Hrs.)
I	HISTORICAL EVALUATION	15
II	AIRCRAFT CONFIGURATIONS	15
III	INTRODUCTION TO PRINCIPLES OF FLIGHT	15
IV	INTRODUCTION TO AIRPLANE STRUCTURES AND MATERIALS	15
V	POWER PLANTS USED IN AIRPLANES	15
	Test & Revision	5
TOTAL		80

AERONAUTICS ENGINEERING

UNIT	Contents	Hours
I	<p>HISTORICAL EVALUATION</p> <p>Early airplanes, biplanes and monoplanes, Developments in aerodynamics, materials, structures and propulsion over the years.</p>	
II	<p>AIRCRAFT CONFIGURATIONS</p> <p>Components of an airplane and their functions. Different types of flight vehicles, classifications. Conventional control, Powered control, Basic instruments for flying, Typical systems for control actuation.</p>	
III	<p>INTRODUCTION TO PRINCIPLES OF FLIGHT</p> <p>Physical properties and structure of the atmosphere, Temperature, pressure and altitude relationships, Evolution of lift, drag and moment. Aerofoils, Mach number, Maneuvers.</p>	
IV	<p>INTRODUCTION TO AIRPLANE STRUCTURES AND MATERIALS</p> <p>General types of construction, Monocoque, semi-monocoque and geodesic construction, Typical wing and fuselage structure. Metallic and non-metallic materials, Use of aluminium alloy, titanium, stainless steel and composite materials.</p>	
V	<p>POWER PLANTS USED IN AIRPLANES</p> <p>Basic ideas about piston, turboprop and jet engines, Use of propeller and jets for thrust production. Comparative merits, Principles of operation of rocket, types of rockets and typical applications, Exploration into space.</p>	

TEXT BOOKS

1. Anderson, J.D., "Introduction to Flight", McGraw-Hill, 1995.

REFERENCE

1. Kermode, A.C., "Flight without Formulae", McGraw-Hill, 1997.

AERONAUTICS ENGINEERING

MODEL QUESTION PAPER - I

Time: 3 Hrs

Max Marks : 75

PART A – Answer any fifteen questions. All Questions carry Equal marks. 15 x 1 = 15

- 1 What is aerodynamic?
- 2 Mention the types of airplanes.
- 3 What are the materials used for airplane structure?
- 4 What is propulsion?
- 5 Classify the flight vehicle.
- 6 Mention the instrument used for flying.
- 7 What is power control?
- 8 What is conventional control?
- 9 Mention the physical properties.
- 10 What is pressure?
- 11 What is the effect of temperature?
- 12 What is Mach number?
- 13 What is composite materials?
- 14 What is monocoque?
- 15 Where non-metallic materials are used in flight?
- 16 What is the use of aluminium alloy in flight?
- 17 What is the use of propeller?
- 18 List the merits of jet.
- 19 What is the principle of rocket?
- 20 List the application of rocket.

PART B: Answer all questions Marks 5 x 12=60

- 21 A Explain the different types of planes. 12
- (OR)**
- B Discuss about the developments of aerodynamics.
- 22 A List the components of airplane. Explain their functions 12
- (OR)**
- B Explain the conventional and powered control. 12
- 23 A Explain the structure of flight based on the atmosphere. 12
- (OR)**
- B i Discuss about the maneuvers. 6
- ii Explain about the aerofoils. 6
- 24 A i Explain about the monocoque and semi-monocoque construction. 8
- ii Explain the about the typical wing. 4
- (OR)**
- B Explain about the materials used for flight. 12
- 25 A Explain the use of propeller and jet for thrust production. 12
- (OR)**
- B Explain the principle of operation of rocket. 12

AERONAUTICS ENGINEERING

MODEL QUESTION PAPER - II

Time: 3 Hrs

Max Marks : 75

PART A – Answer any fifteen questions. All Questions carry Equal marks. 15 x 1 = 15

- 1 What is aerodynamic?
- 2 Mention the types of airplanes.
- 3 What are the materials used for airplane structure?
- 4 What is propulsion?
- 5 Classify the flight vehicle.
- 6 Mention the instrument used for flying.
- 7 What is power control?
- 8 What is conventional control?
- 9 Mention the physical properties.
- 10 What is pressure?
- 11 What is the effect of temperature?
- 12 What is Mach number?
- 13 What is composite materials?
- 14 What is monocoque?
- 15 Where non-metallic materials are used in flight?
- 16 What is the use of aluminium alloy in flight?
- 17 What is the use of propeller?
- 18 List the merits of jet.
- 19 What is the principle of rocket?
- 20 List the application of rocket.

PART B: Answer all questions Marks 5 x 12=60

- 21 A Explain the different types of planes. 12
(OR)
B Discuss about the developments of aerodynamics.
- 22 A List the components of airplane. Explain their functions 12
(OR)
B Explain the conventional and powered control. 12
23 A Explain the structure of flight based on the atmosphere. 12
(OR)
B i Discuss about the maneuvers. 6
ii Explain about the aerofoils. 6
- 24 A i Explain about the monocoque and semi-monocoque construction. 8
ii Explain the about the typical wing. 4
(OR)
B Explain about the materials used for flight. 12
- 25 A Explain the use of propeller and jet for thrust production. 12
(OR)
B Explain the principle of operation of rocket. 12



DIPLOMA IN MECHANICAL ENGINEERING

L-SCHEME

2011-2012

**22064 – COMPUTER INTEGRATED
MANUFACTURING PRACTICAL**

**DIRECTORATE OF TECHNICAL EDUCATION
GOVERNMENT OF TAMILNADU**

L-SCHEME
(Implements from the Academic year 2011-2012 onwards)

Course Name : DIPLOMA IN AUTOMOB ENGINEERING
Course Code : 1020
Subject Code : 22064
Semester : VI
Subject Title : Computer Integrated Manufacturing Practical

TEACHING AND SCHEME OF EXAMINATIONS:

No. of Weeks per Semester : 16 Weeks

Subject	Instructions		Examination			Duration
	Hours/Week	Hours/Semester	Marks			
Computer Integrated Manufacturing Practical	6	96	Internal Assessment	Board Examination	Total	3 Hrs
			25	75	100	

OBJECTIVES:

- Study the working principle of CNC machines
- Study the datum points and offsets.
- Differentiate incremental System with absolute system
- Study the simulation software package.
- Write program and simulate in the Lathe software and Milling software.
- Prepare a part program, edit and execute in CNC Turning centre.
- Prepare a part program, edit and execute in CNC Machining centre.
- Produce components in the CNC Turning centre and CNC Machining centre.

Introductions (12Hours)

1. Study of CNC lathe, milling
2. Study of international standard G-Codes and M-Codes
3. Program writing – Turning simulator – Milling simulator, IS practice – commands – menus
4. Editing the program in the CNC machines.
5. Execute the program in the CNC machines.

PART A (Simulation) – 36 Hrs.

CNC Turning Simulation

1. Create a part program for step turning and simulate in the software - Using Linear interpolation.

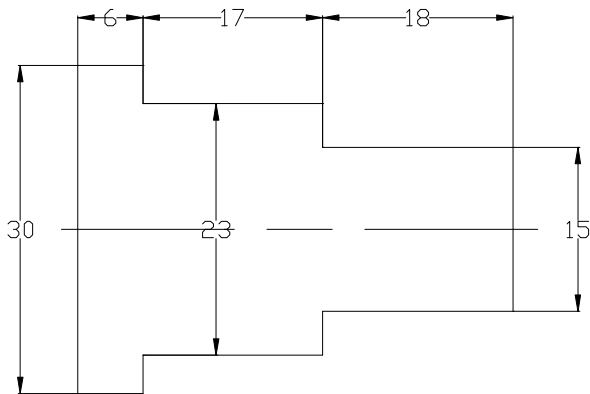

2. Create a part program for taper turning and simulate in the software - Using Box turning cycle.

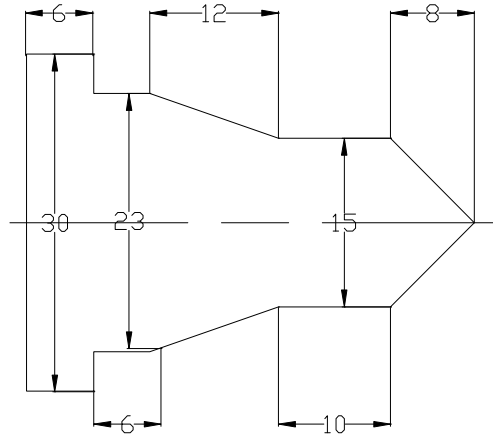

3. Create a part program for circular interpolation and simulate in the software - Using Circular interpolation.

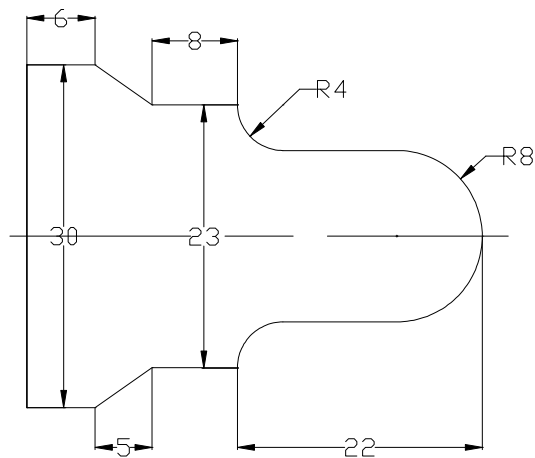

4. Create a part program for multiple turning operations and simulate in the software - Using Stock removal cycle.

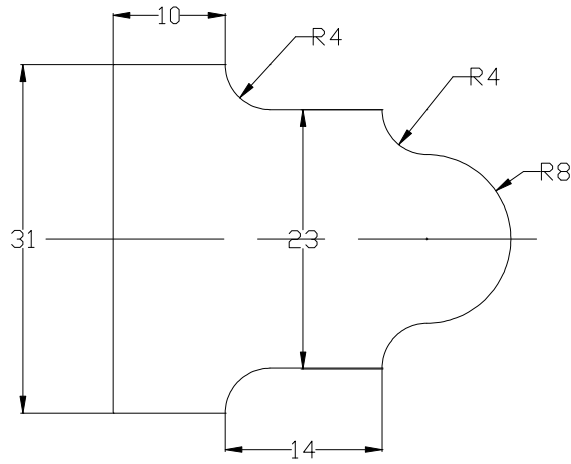

5. Create a part program for thread cutting, grooving and simulate in the software - Using canned cycle.

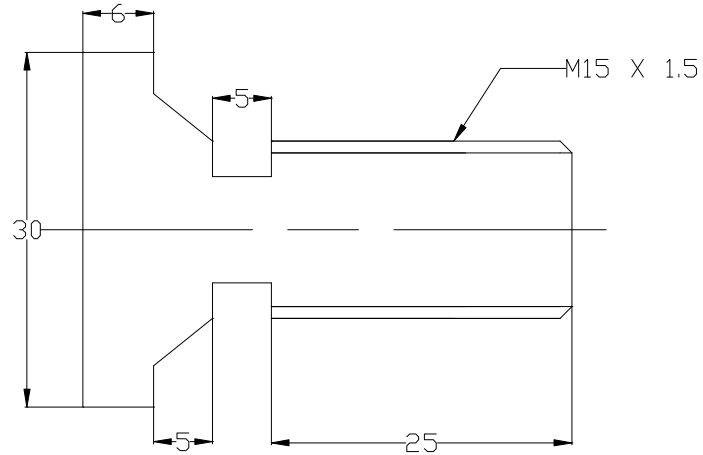

6. Create a part program for internal drills, boring and simulate in the software.

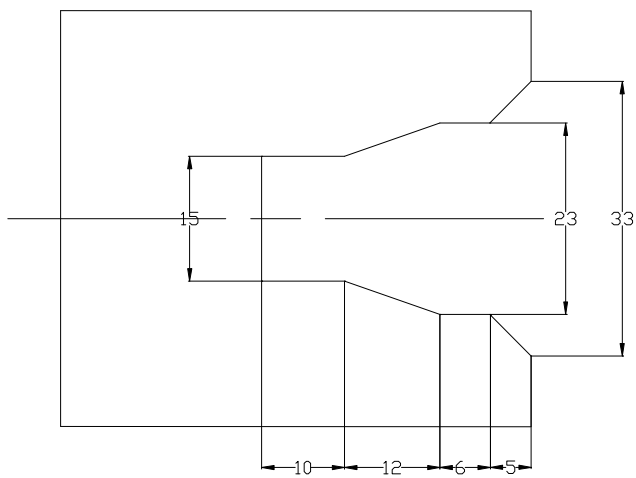

CNC Milling Simulation

1. Create a part program for grooving and simulate in the software - Using Linear interpolation and Circular interpolation.

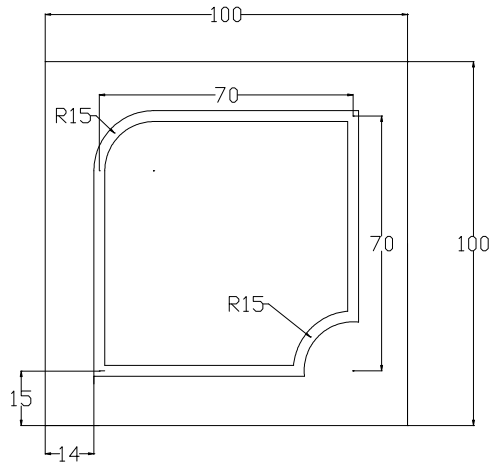

2. Create a part program for drilling and counter sinking and simulate in the software - Using canned cycle.

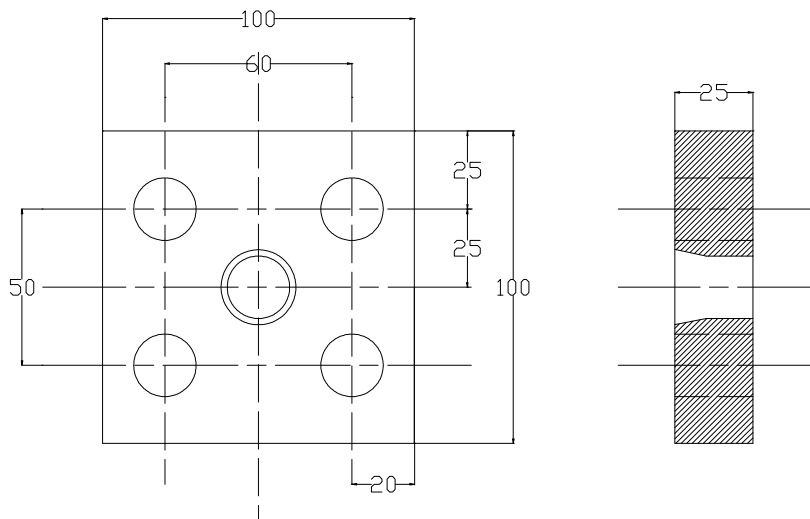

3. Create a part program for mirroring and simulate in the software - Using subprogram.

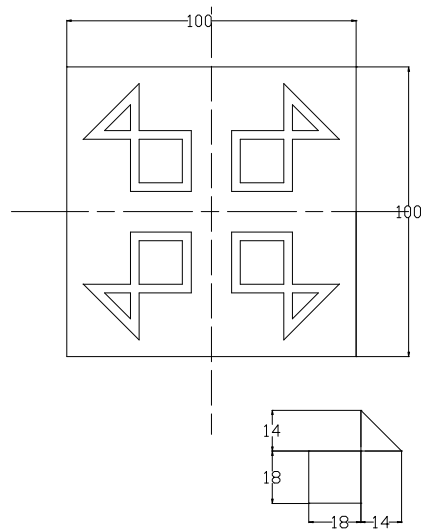

4. Create a part program for rectangular and circular pocketing and simulate in the software - Using canned cycle.

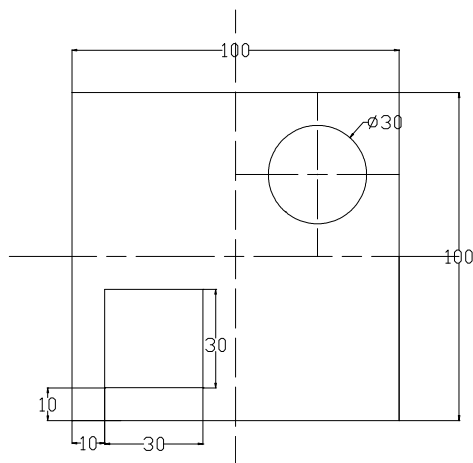

PART B (Machining) – 36 Hrs.

CNC Turning Machine Material: Aluminum or acrylic fibre rod or Plastic

1. Using Box turning cycle – Create a part program for step and taper turning and produce component in the Machine.

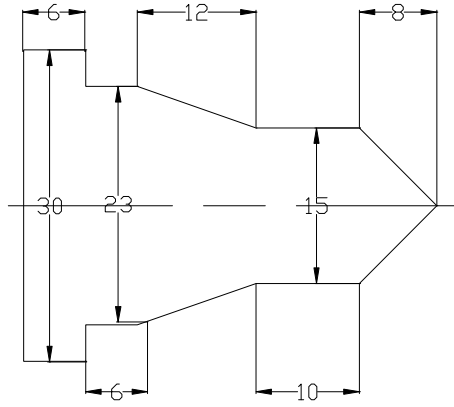

2. Using Circular interpolation - Create a part program for circular interpolation and produce component in the Machine.

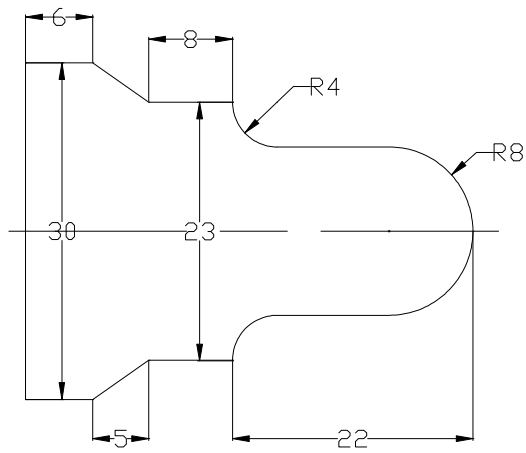

3. Using Stock removal cycle – Create a part program for multiple turning operations and produce component in the Machine.

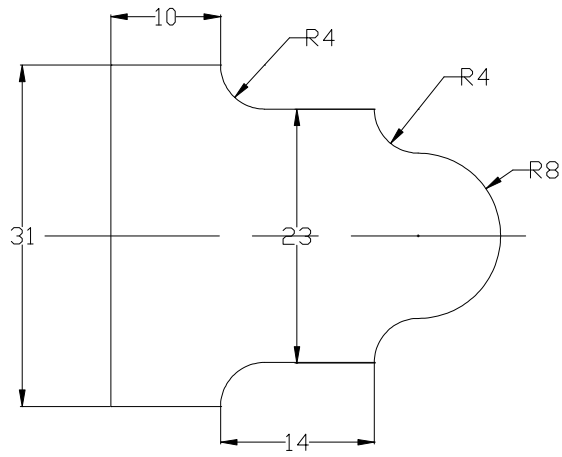

4. Using canned cycle - Create a part program for thread cutting, grooving and produce component in the Machine.

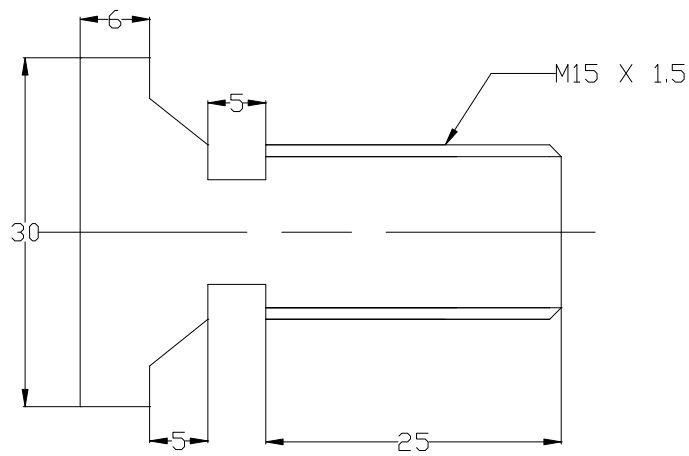

CNC Milling Machine Material: Aluminum or acrylic fibre or plastic

1. Using Linear interpolation and Circular interpolation – Create a part program for grooving and produce component in the Machine.

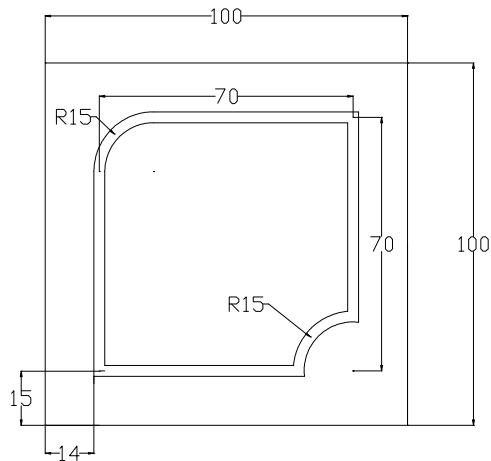

2. Using canned cycle - Create a part program for drilling, counter sinking and produce component in the Machine

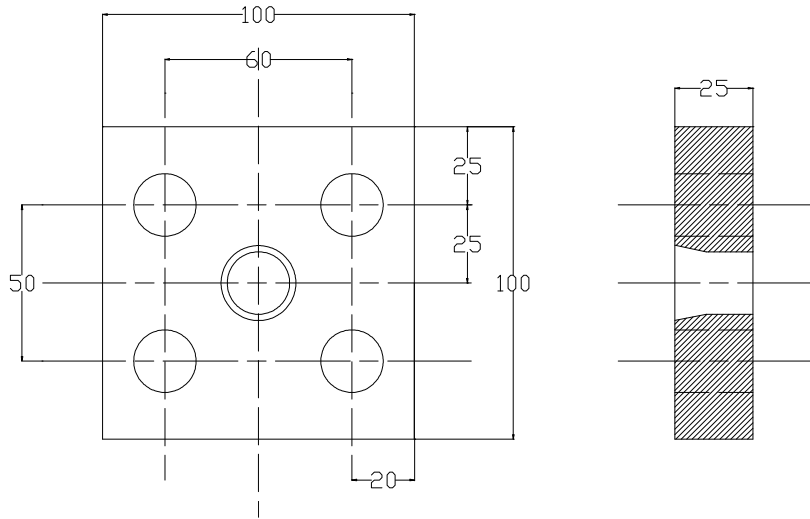

3. Using subprogram - Create a part program for mirroring and produce component in the Machine.

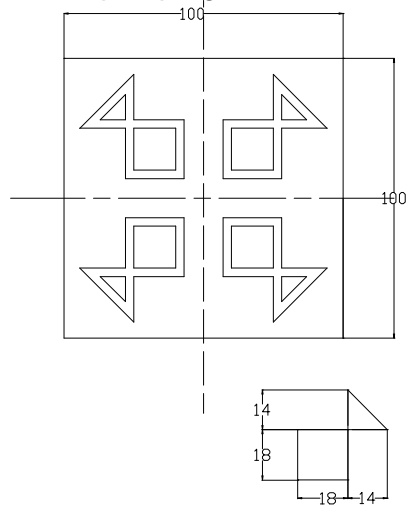

Revision and Test

12 Hrs

BOARD EXAMINATION

Note: Examination should be conducted to produce the components in the Machine. The exercises should be given accordingly by the external examiner.
Students should be allowed to the machine after simulation and with print out.

Allocation of marks for Board Examination

PART –A

Writing the part program	:	20
Execution/ Simulation in the software	:	20

PART-B

Enter and editing the program in the machine	:	20
Component machining	:	10
Viva voice	:	5
External Marks	:	75

Minimum Facilities required for 60 intakes. Based on the intake strength the facilities should be improved.

1. Personal computer (Pentium processor) – 15 Nos.
2. Off line CNC Lathe and Milling simulation software – 15 users.
3. CNC Turning Machine - 2 Nos.
4. CNC Milling Machine – 2 Nos.
5. Laser Printer – 1 No.



DIPLOMA IN AUTOMOBILE ENGINEERING

L-SCHEME

2011-2012

22165 - AUTOMOBILE WORKSHOP PRACTICAL

**DIRECTORATE OF TECHNICAL EDUCATION
GOVERNMENT OF TAMILNADU**

L-SCHEME
(Implements from the Academic year 2011-2012 onwards)

Course Name : DIPLOMA IN AUTOMOBILE ENGINEERING
Course Code : 1021
Subject Code : 22165
Semester : VI
Subject Title : **AUTOMOBILE WORKSHOP PRACTICAL**

TEACHING AND SCHEME OF EXAMINATIONS:

No. of Weeks per Semester : 16 Weeks

Subject	Instructions		Examination			Duration
	Hours/Week	Hours/Semester	Marks			
AUTOMOBILE WORKSHOP PRACTICAL	4	64	Internal Assessment	Board Examination	Total	3 Hrs
			25	75	100	

Objective

To impart the knowledge to learn the maintenance of the vehicle. This will create an opportunity to identify the fault and methods to rectify the fault.

Part A

1. Milling splines on the shaft.
2. Refacing and lapping of valves.
3. Valve seat grinding, cutting valve seat with angle cutter and lapping.
4. Truing brake drum on a brake drum lathe.
5. Reboring and honing of cylinders.
6. Line boring of main bearings.

Part B

1. Water wash two wheeler / Three wheeler and Drain and replenish lubricants- Adjust, remove links & lubricate drive chain
2. Remove, clean, check, refit/replace – fuel tank, fuel pipes, fuel tap operation
3. Clean, Check and Adjust spark plug - Two wheeler / four wheeler.
4. Replace brake components, adjust brake & top-up brake fluid and adjust clutch play
5. Replace control cables – clutch, brake & accelerator cables – adjust clutch & brake plays
6. Check the electrical circuit and replace bulbs for two wheeler / four wheeler.

BOARD EXAMINATION - DETAILED ALLOCATION

Note: Question paper should have two questions one from each part.

PART A	45
PART B	25
Viva Voice	5
TOTAL	75

Resources required

1. Two wheeler – 2 nos.
 2. Four wheeler - 1 No.
 3. Wheel truing machine – 1 no.
 4. Milling machine – 1 No.
 5. Valve grinding machine – 1 No.
 6. Honing / boring machine – 1 No.
 7. Engine lathe – 1 Nos
 8. Work table with 4 Bench vices – 5 Nos.
 9. Spanner set (6 to 32 mm) D/E and Ring - 5 sets
 10. Special tools (Wheel spanner ,Wrenches and Pliers etc.,) - 2 sets
 11. Screw drivers - 5 sets (Various sizes)
 12. Grease gun – 5 nos.
 13. Feeler gauges – 5 nos.
 14. Steel rule - 5 nos.
 15. Adjustable spanner –5 nos.
 16. Socket spanner – 5 nos.
 17. Allenkey set – 5 nos.
- Other workshop tools.



DIPLOMA IN AUTOMOBILE ENGINEERING

L-SCHEME

2011-2012

**22184 - TWO AND THREEWHEELER
TECHNOLOGY PRACTICAL**

**DIRECTORATE OF TECHNICAL EDUCATION
GOVERNMENT OF TAMILNADU**

L-SCHEME
(Implements from the Academic year 2011-2012 onwards)

Course Name : DIPLOMA IN AUTOMOBILE ENGINEERING
Course Code : 1021
Subject Code : 22184
Semester : VI
Subject Title : **TWO AND THREEWHEELER TECHNOLOGY PRACTICAL**

TEACHING AND SCHEME OF EXAMINATIONS:

No. of Weeks per Semester : 16 Weeks

Subject	Instructions		Examination			Duration
	Hours/ Week	Hours/ Semester	Marks			
TWO AND THREEWHEELER TECHNOLOGY PRACTICAL	4	64	Internal Assessment	Board Examination	Total	3 Hrs
			25	75	100	

List of Experiments

1. Dismantle, check and assemble the radiator and water pump.
2. Replace the Oil filter and Inspect of clogged oil lines and oil passages
3. Dismantle and Service of oil pump and Change the oil
4. Dismantle and Re-assemble the clutch used in two and three wheelers.
5. Adjust the clutch and inspect the common troubles and their causes.
6. Overhaul and Lubricate the gear box.
7. Dismantle and Refit the propeller shaft
8. Dismantle, lubricate and refit the differential
9. Dismantle and refit the rear axle – three wheeler
10. Check frame alignment and dismantle the leaf spring assembly
11. Dismantle the front suspension and rear suspension of the motor bike.
12. Dismantle the front fork in motor cycles and test of shock absorber.
13. Dismantle, service and refit the disc brake – Service the Master Cylinder and Wheel cylinder
14. Adjust the brakes and reline the brake shoe.
15. Dismantle and refit the muffler – Replace the Catalytic converter.

BOARD EXAMINATION - DETAILED ALLOCATION

Note: One question should be given. Students should dismantle and assemble the components after verification by the examiner.

Procedure	20
Dismantling	20
Assembly	20
Tool handling	10
Viva Voice	5
TOTAL	75

Resources required

Two wheeler - 3 Nos.

Three wheeler – 2 Nos.

Special tools – 5 sets

Each experiment separate components are required.

Sufficient quantity of tools.

Proper material handling devices.



DIPLOMA IN AUTOMOBILE ENGINEERING

L-SCHEME

2011-2012

**22185 - TRACTORS AND FARM EQUIPMENTS
PRACTICAL**

**DIRECTORATE OF TECHNICAL EDUCATION
GOVERNMENT OF TAMILNADU**

L-SCHEME
(Implements from the Academic year 2011-2012 onwards)

Course Name : DIPLOMA IN AUTOMOBILE ENGINEERING
Course Code : 1021
Subject Code : 22185
Semester : VI
Subject Title : **TRACTORS AND FARM EQUIPMENTS PRACTICAL**

TEACHING AND SCHEME OF EXAMINATIONS:

No. of Weeks per Semester : 16 Weeks

Subject	Instructions		Examination			Duration
	Hours/Week	Hours/Semester	Marks			
TRACTORS AND FARM EQUIPMENTS PRACTICAL	4	64	Internal Assessment	Board Examination	Total	3 Hrs
			25	75	100	

List of Experiments

1. Driving the Tractor – Driving Practice only.
2. Hitching the given implement with the tractor by three point linkage and unhitching practice.
3. Ploughing practice with Mould Board Plough.
4. Ploughing practice with DISC harrows.
5. Ploughing practice with Tiller.
6. Power Tiller – study, its usage in the field and maintenance.
7. Cage wheel – fitting the cage wheel after removing the wheels from Tractor.
8. Spraying practice with power sprayer and its maintenance.
9. Tractor maintenance Schedule.

BOARD EXAMINATION - DETAILED ALLOCATION

Note: One question should be given.

Procedure	20
Exercise	30
Handling	20
Viva Voice	5
TOTAL	75

Resources required

Tractor – 1 No.
 Power triller – 1 No.
 Ploughing kits
 Power sprayer - 1
 Special tools – 5 sets



DIPLOMA IN AUTOMOBILE ENGINEERING

L-SCHEME

2011-2012

22186 - AERONAUTICS ENGINEERING PRACTICAL

**DIRECTORATE OF TECHNICAL EDUCATION
GOVERNMENT OF TAMILNADU**

L-SCHEME
L-SCHEME
(Implements from the Academic year 2011-2012 onwards)

Course Name : DIPLOMA IN AUTOMOBILE ENGINEERING
Course Code : 1021
Subject Code : 22186
Semester : VI
Subject Title : **AERONAUTICS ENGINEERING PRACTICAL**

TEACHING AND SCHEME OF EXAMINATIONS:

No. of Weeks per Semester : 16 Weeks

Subject	Instructions		Examination			Duration
	Hours/Week	Hours/Semester	Marks			
AERONAUTICS ENGINEERING PRACTICAL	4	64	Internal Assessment	Board Examination	Total	3 Hrs
			25	75	100	

LIST OF EXPERIMENTS

1. Verification of Maxwell's Reciprocal Theorem
2. Tensile testing using the UTM
3. Verification of the Superposition Theorem
4. Buckling Load of Slender Eccentric Columns
5. Shear Failure of Bolted and Rivetted Joints
6. Bending Modulus of a Sandwich Beam
7. Application of Bernoulli's Equation – Venturimeter and Orifice meter.
8. Frictional Loss in laminar flow through pipes.
9. Frictional Loss in turbulent flow through pipes.
10. Calibration of a Subsonic Wind tunnel.

BOARD EXAMINATION - DETAILED ALLOCATION

Note: One question should be given.

Procedure	15
Observation	20
Calculation / Result	35
Viva Voice	5
TOTAL	75

Resources required

- UTM – 1 No.
- Shear testing equipment – 1No.
- Flow through Pipes kit – 1 No.
- Wind tunnel kit – 1No.
- Experimental kit - 1 No / Each.



DIPLOMA IN AUTOMOBILE ENGINEERING

L-SCHEME

2011-2012

22167 – PROJECT WORK

**DIRECTORATE OF TECHNICAL EDUCATION
GOVERNMENT OF TAMILNADU**

L-SCHEME
(Implements from the Academic year 2011-2012 onwards)

Course Name : DIPLOMA IN AUTOMOBILE ENGINEERING
Course Code : 1021
Subject Code : 22167
Semester : VI
Subject Title : Project Work

TEACHING AND SCHEME OF EXAMINATIONS:

No. of Weeks per Semester : 16 Weeks

Subject	Instruction		Examination		
	Hours/ Week	Hours/ Semester	Assessment Marks		
			Internal	Board Exam	Total
PROJECT WORK	6	96	25	75	100

Minimum Marks for Pass is 50 out of which minimum 35 marks should be obtained out of 75 marks in the board Examination alone.

OBJECTIVES:

- Implement the theoretical and practical knowledge gained through the curriculum into an application suitable for a real practical working environment preferably in an industrial environment
- Get exposure on industrial environment and its work ethics.
- Understand what entrepreneurship is and how to become an entrepreneur.
- Learn and understand the gap between the technological knowledge acquired through curriculum and the actual industrial need and to compensate it by acquiring additional knowledge as required.
- Carry out cooperative learning through synchronous guided discussions within the class in key dates, asynchronous document sharing and discussions, as well as to prepare collaborative edition of the final project report.
- Understand the facts and importance of environmental management.

Understand and gain knowledge about disaster management

INTERNAL ASSESSMENT:

The internal assessment should be calculated based on the review of the progress of the work done by the student periodically as follows.

Detail of assessment	Period of assessment	Max. Marks
First Review	6 th week	10
Second Review	14 th week	10
Attendance	Entire semester	5
Total		25

EVALUATION FOR BOARD EXAMINATION:

Details of Mark allocation	Max Marks
Marks for Report Preparation, Demo, Viva-voce	45
Marks for answers of 15 questions which is to be set by the external examiner from the given question bank consisting of questions in the following three topics Entrepreneurship, Disaster Management and Environmental Management. Out of fifteen questions five questions to appear from each of the above topics i.e. 5 questions x 3 topics = 15 questions 15 questions x 2marks = 30 Marks	30
Total	75

DETAILED SYLLABUS

ENTREPRENEURSHIP, ENVIRONMENTAL & DISASTER MANAGEMENT

1. ENTREPRENEURSHIP

- 1.1 Introduction – Entrepreneur - characteristics of Entrepreneur - contributions of an Entrepreneur - functions of entrepreneur - Barriers to entrepreneurship - Roll of government in Entrepreneurial development.
- 1.2 Small scale industries (SSI) - SSI role in country's economic growth – importance of SSI - starting of an SSI - Government organization and Non-governmental organizations supporting SSI - DIC, NSIC, SIDO, KVIC, Development banks and their objectives - role of commercial banks in assisting SSI - Women entrepreneurs and opportunities – Subsidy and concessions to Small Scale Industries.

2. ENVIRONMENTAL MANAGEMENT

- 2.1 Introduction – Environmental Ethics – Assessment of Socio Economic Impact – Environmental Audit – Mitigation of adverse impact on Environment – Importance of Pollution Control – Types of Industries and Industrial Pollution.
- 2.2 Solid waste management – Characteristics of Industrial wastes – Methods of Collection, transfer and disposal of solid wastes – Converting waste to energy – Hazardous waste management Treatment technologies.
- 2.3 Waste water management – Characteristics of Industrial effluents – Treatment and disposal methods – Pollution of water sources and effects on human health.
- 2.4 Air pollution management – Sources and effects – Dispersion of air pollutants – Air pollution control methods – Air quality management.
- 2.5 Noise pollution management – Effects of noise on people – Noise control methods.

3. DISASTER MANAGEMENT

- 3.1 Introduction – Disasters due to natural calamities such as Earthquake, Rain, Flood, Hurricane, Cyclones etc – Man made Disasters – Crisis due to fires, accidents, strikes etc – Loss of property and life..
- 3.2 Disaster Mitigation measures – Causes for major disasters – Risk Identification – Hazard

Zones – Selection of sites for Industries and residential buildings – Minimum distances from Sea – Orientation of Buildings – Stability of Structures – Fire escapes in buildings - Cyclone shelters – Warning systems.

- 3.3 Disaster Management – Preparedness, Response, Recovery – Arrangements to be made in the industries / factories and buildings – Mobilization of Emergency Services - Search and Rescue operations – First Aids – Transportation of affected people – Hospital facilities – Fire fighting arrangements – Communication systems – Restoration of Power supply – Getting assistance of neighbors / Other organizations in Recovery and Rebuilding works – Financial commitments – Compensations to be paid – Insurances – Rehabilitation.

LIST OF QUESTIONS

1. ENTREPRENEURSHIP

1. Define the term Entrepreneur.
2. What is Entrepreneurship? Explain.
3. List the various stages of decisions an entrepreneur has to make before reaching the goal of his project.
4. What is innovation?
5. State briefly the role of an entrepreneur in the economic growth of a country.
6. List the characteristics of an Entrepreneur.
7. What are the critical elements of an Entrepreneur?
8. State the major functions of an Entrepreneur.
9. What are barriers to Entrepreneurship?
10. Define Small Scale Industry.
11. What are the qualities of Entrepreneur?
12. What are the benefits of Entrepreneur?
13. What are the various SSI that can flourish in your district?
14. Identify the infrastructural needs for an industry.
15. What are the various agencies involved in the establishment and development of various SSI?
16. Name some of the agencies funding SSI.
17. Explain the roles played by Government in Entrepreneurial development.
18. What are the various concessions and incentives available for a SSI.
19. Name some consumer products with wide demand that can be manufactured by a SSI?
20. What is feasibility study?
21. What is the importance of SSI?
22. What is DIC? State its functions.
23. What is NSIC? State its functions.
24. What is SIDO? State its functions.
25. Name the Development Banks in India working towards Entrepreneurial development.
26. State the role of commercial bank in assisting SSI sector.
27. What are the different phases of Entrepreneurial Development programme?

28. What is an Industrial Estate?
29. What are the facilities available in an Industrial Estate?
30. Identify the various training agencies associated with SSI.
31. List the governmental agencies from whom you shall get financial assistance for a SSI.
32. What is KVIC? State its objectives.
33. Name some state finance corporations.
34. What are the steps involved in preparing a feasibility report?
35. What are the factors to be considered regarding raw materials for a SSI?
36. What are the features of a SSI?
37. What are the advantages of becoming an Entrepreneur?
38. Name the Organizations offering assistance for the development of Women entrepreneurs.
39. State the business opportunities for Women entrepreneurs.
40. State the different subsidies given to SSI's.

2. ENVIRONMENTAL MANAGEMENT

1. What is the responsibility of an Engineer-in-charge of an Industry with respect to Public Health?
2. Define Environmental Ethic.
3. How Industries play their role in polluting the environment?
4. What is the necessity of pollution control? What are all the different organizations you know, which deal with pollution control?
5. List out the different types of pollutions caused by a Chemical / Textile / Leather / Automobile / Cement factory.
6. What is meant by Hazardous waste?
7. Define Industrial waste management.
8. Differentiate between garbage, rubbish, refuse and trash based on their composition and source.
9. Explain briefly how the quantity of solid waste generated in an industry could be reduced.
10. What are the objectives of treatments of solid wastes before disposal?
11. What are the different methods of disposal of solid wastes?
12. Explain how the principle of recycling could be applied in the process of waste minimization.
13. Define the term 'Environmental Waste Audit'.
14. List and discuss the factors pertinent to the selection of landfill site.
15. Explain the purpose of daily cover in a sanitary landfill and state the minimum desirable depth of daily cover.
16. Describe any two methods of converting waste into energy.
17. What actions, a local body such as a municipality could take when the agency appointed for collecting and disposing the solid wastes fails to do the work continuously for number of days?
18. Write a note on Characteristics of hazardous waste.
19. What is the difference between municipal and industrial effluent ?
20. List few of the undesirable parameters / pollutants anticipated in the effluents from oil refinery industry / thermal power plants / textile industries / woolen mills / dye industries / electroplating industries / cement plants / leather industries (any two may be asked)

21. Explain briefly the process of Equalization and Neutralization of waste water of varying characteristics discharged from an Industry.
22. Explain briefly the Physical treatments “Sedimentation” and “Floatation” processes in the waste water treatment.
23. Explain briefly when and how chemical / biological treatments are given to the waste water.
24. List the four common advanced waste water treatment processes and the pollutants they remove.
25. Describe refractory organics and the method used to remove them from the effluent.
26. Explain biological nitrification and de-nitrification.
27. Describe the basic approaches to land treatment of Industrial Effluent.
28. Describe the locations for the ultimate disposal of sludge and the treatment steps needed prior to ultimate disposal.
29. List any five Industries, which act as the major sources for Hazardous Air Pollutants.
30. List out the names of any three hazardous air pollutants and their effects on human health.
31. Explain the influence of moisture, temperature and sunlight on the severity of air pollution effects on materials.
32. Differentiate between acute and chronic health effects from Air pollution.
33. Define the term Acid rain and explain how it occurs.
34. Discuss briefly the causes for global warming and its consequences
35. Suggest suitable Air pollution control devices for a few pollutants and sources.
36. Explain how evaporative emissions and exhaust emissions are commonly controlled.
37. What are the harmful elements present in the automobile smokes? How their presence could be controlled?
38. What is the Advantage of Ozone layer in the atmosphere? State few reasons for its destruction.
39. Explain the mechanism by which hearing damage occurs.
40. List any five effects of noise other than hearing damage.
41. Explain why impulsive noise is more dangerous than steady state noise.
42. Explain briefly the Source – Path – Receiver concept of Noise control.
43. Where silencers or mufflers are used ? Explain how they reduce the noise.
44. Describe two techniques to protect the receiver from hearing loss when design / redress for noise control fail.
45. What are the problems faced by the people residing along the side of a railway track and near to an Airport? What provisions could be made in their houses to reduce the problem?

3. DISASTER MANAGEMENT

1. What is meant by Disaster Management? What are the different stages of Disaster management?
2. Differentiate Natural Disasters and Man made Disasters with examples.
3. Describe the necessity of Risk identification and Assessment Surveys while planning a project.
4. What is Disasters recovery and what does it mean to an Industry?
5. What are the factors to be considered while planning the rebuilding works after a major disaster due to flood / cyclone / earthquake? (Any one may be asked)
6. List out the public emergency services available in the state, which could be approached for help during a natural disaster.
7. Specify the role played by an Engineer in the process of Disaster management.

8. What is the cause for Earthquakes? How they are measured? Which parts of India are more vulnerable for frequent earthquakes?
9. What was the cause for the Tsunami 2004 which inflicted heavy loss to life and property along the coast of Tamilnadu ? Specify its epicenter and magnitude.
10. Specify the Earthquake Hazard Zones in which the following towns of Tamilnadu lie: (a) Chennai (b) Nagapattinam (c) Coimbatore (d) Madurai (e) Salem.
11. Which parts of India are experiencing frequent natural calamities such as (a) heavy rain fall (b) huge losses due to floods (c) severe cyclones
12. Define basic wind speed. What will be the peak wind speed in (a) Very high damage risk zone – A, (b) High damage risk zone, (c) Low damage risk zone.
13. Specify the minimum distance from the Sea shore and minimum height above the mean sea level, desirable for the location of buildings.
14. Explain how the topography of the site plays a role in the disasters caused by floods and cyclones.
15. Explain how the shape and orientation of buildings could reduce the damages due to cyclones.
16. What is a cyclone shelter ? When and where it is provided ? What are its requirements ?
17. What Precautionary measures have to be taken by the authorities before opening a dam for discharging the excess water into a canal/river ?
18. What are the causes for fire accidents ? Specify the remedial measures to be taken in buildings to avoid fire accidents.
19. What is a fire escape in multistoried buildings ? What are its requirements ?
20. How the inmates of a multistory building are to be evacuated in the event of a fire/Chemical spill/Toxic Air Situation/ Terrorist attack, (any one may be asked).
21. Describe different fire fighting arrangements to be provided in an Industry.
22. Explain the necessity of disaster warning systems in Industries.
23. Explain how rescue operations have to be carried out in the case of collapse of buildings due to earthquake / blast / Cyclone / flood.
24. What are the necessary steps to be taken to avoid dangerous epidemics after a flood disaster?
25. What relief works that have to be carried out to save the lives of workers when the factory area is suddenly affected by a dangerous gas leak / sudden flooding ?
26. What are the difficulties faced by an Industry when there is a sudden power failure? How such a situation could be managed?
27. What are the difficulties faced by the Management when there is a group clash between the workers? How such a situation could be managed?
28. What will be the problems faced by the management of an Industry when a worker dies because of the failure of a mechanical device due to poor maintenance? How to manage such a situation ?
29. What precautionary measures have to be taken to avoid accidents to labourers in the Industry in a workshop / during handling of dangerous Chemicals / during construction of buildings / during the building maintenance works.
30. Explain the necessity of medical care facilities in an Industry / Project site.
31. Explain the necessity of proper training to the employees of Industries dealing with hazardous products, to act during disasters.
32. What type of disaster is expected in coal mines, cotton mills, Oil refineries, ship yards and gas plants?
33. What is meant by Emergency Plan Rehearsal? What are the advantages of such Rehearsals?

34. What action you will take when your employees could not reach the factory site because of continuous strike by Public Transport workers?
35. What immediate actions you will initiate when the quarters of your factory workers are suddenly flooded due to the breach in a nearby lake / dam, during heavy rain?
36. What steps you will take to avoid a break down when the workers union of your Industry have given a strike notice?
37. List out few possible crisis in an organization caused by its workers? What could be the part of the middle level officials in managing such crisis?
38. What types of warning systems are available to alert the people in the case of predicted disasters, such as floods, cyclone etc.
39. Explain the necessity of Team work in the crisis management in an Industry / Local body.
40. What factors are to be considered while fixing compensation to the workers in the case of severe accidents causing disability / death to them?
41. Explain the legal / financial problems the management has to face if safety measures taken by them are found to be inadequate.
42. Describe the importance of insurance to men and machinery of an Industry dealing with dangerous jobs.
43. What precautions have to be taken while storing explosives in a match/ fire crackers factory?
44. What are the arrangements required for emergency rescue works in the case of Atomic Power Plants?
45. Why residential quarters are not constructed nearer to Atomic Power Plants?

✍️ *** ✍️